

Product Catalogue
03/2023

PVC-U windows

activPilot Comfort PADK, PADM, PADS, PAD

The fitting system with parallel action

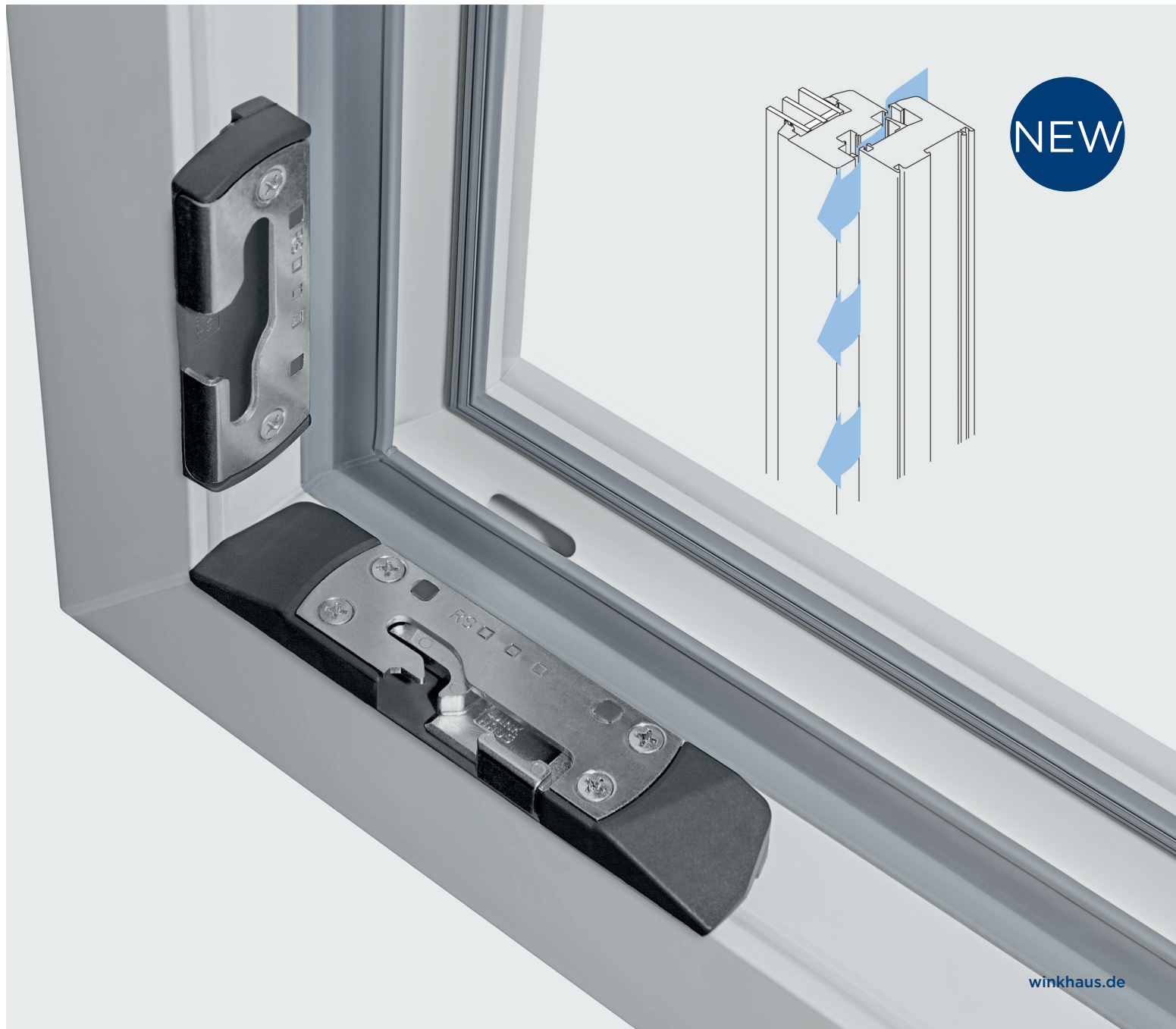

NEW

1

The processing details regarding burglary-resistant window units can be gathered from the DIN EN 1627 - 1630 system documentation. The lists of fittings in this catalogue are merely intended to give application examples. Get in touch with your Winkhaus contact partner for more details.



The following information and illustrations reflect the current state of our development and manufacturing of this product. In order to achieve customer satisfaction and reliability of the hardware components we reserve the right to change the product.

Any information given in this document has been compiled and verified with the greatest care.

Some of the indicated dimensions are rounded measures!





Due to the constant technical progress, changes in legislation and other inevitable changes, we cannot accept any responsibility for the accuracy and completeness of the contents. We are always thankful for suggestions and comments.

Taking into account the information and facts given here with regard to windows (and doors), the fitting system can easily be installed.

Copyright:

© Aug. Winkhaus GmbH & Co. KG, all rights and modifications are reserved.

Table of contents

| | | |
|---|-----------------|---|
| General product information | Pages 4 - 15 | |
| General product information activPilot Comfort | Pages 16 - 17 | |
| activPilot Comfort PADK | Pages 19 - 124 |  |
| <ul style="list-style-type: none"> - Turn, tilt, open to parallel position and close - Possible up to resistance class RC2, according to DIN EN 1627 - 1630 | | |
| activPilot Comfort PADM | Pages 125 - 190 |  |
| <p>Motorised parallel action and turn fitting system</p> <ul style="list-style-type: none"> - Suitable for user-independent room ventilation according to DIN 1946-6:2009-05 - Possible up to resistance class RC2, according to DIN EN 1627 - 1630 - Automatic and time-adjusted ventilation integrated - Flexible window operation via radio remote control unit or touch surface | | |
| activPilot Comfort PADS | Pages 191 - 252 |  |
| <ul style="list-style-type: none"> - Fitting system with parallel action, turn and close functions - For radius head and studio windows and other special types of windows | | |
| activPilot Comfort PAD | Pages 253 - 313 |  |
| <ul style="list-style-type: none"> - Fitting system with parallel action, turn and close functions - Handle opposite to hinge side, but bottom horizontal position is also possible - Possible up to resistance class RC2, according to DIN EN 1627 - 1630 | | |

Many windows, many formats, one single fitting system.

activPilot: The standard of turn-tilt fittings

Developing a new system of fittings from the initial drafts to market maturity is a time consuming process. It is not just a question of creative ideas, precise calculations and countless series of tests, but also of intensive monitoring of people and markets, evaluating current trends and ongoing analysis of general technical developments. To be able to pull together all of this information, and apply our years of experience, to develop targeted, premium solutions that offer fitters and users a whole new range of opportunities. It is this constant drive towards precision that has made Winkhaus one of the leading enterprises in the field of window and door technology. This is evident by the large number of industry standards that Winkhaus has established in over 160 years.

The standard of activPilot

In developing activPilot we created all the solutions needed for the next-generation window fitting standard within a single system. An intelligent, clearly structured modular system with far less components than was previously typical, activPilot meets all requirements placed on a modern range of fittings. activPilot is suitable for any shape of window, any window material and any level of automation, from manual mounting to fully automated serial production. The high level of flexibility, the attractive auxiliary functions, the new locking system and the functional design all ensure that your business is perfectly geared today to meet your customers' needs and future requirements.

Modular design

activPilot optimises window construction. For the window builder, less components and multifunctionality mean uncomplicated and fast processing and rational mounting. Pre-mounted components and the unique design additionally ensure that additional functions and safety classes can be achieved easily by retrofitting. activPilot thus sets the scene for sustainably cutting your production, warehousing, logistics and administration costs.

The locking system with octagonal locking bolts

activPilot enhances comfort. The functionally perfect locking mechanism not only guarantees precise entry of the locking bolt into the frame keep, but also a perfect seal. This is ensured by the increased air gap tolerance and the new octagonal locking bolt which allows easy adjustment of the contact pressure. Even adjusting forces and the non-positive and positive system fit of the components give this fitting the required stability and long-term functionality.

Design

activPilot offers you and your customers real added value. Surprising details, discreet accents, ergonomic design and comprehensive functions characterise the overall concept of the fitting system. In short its attractive design will be a crucial factor when it comes to your customers making a purchase decision. activPilot also offers other convincing arguments such as outstanding durability, easy-to-clean surfaces, intuitive operation and, last but not least, aesthetically pleasing windows.

Surface

activPilot fittings feature a surface refinement finish based on nanotechnology, which is applied in our in-house plating shop. This surface stands out due to its very high resistance to all environmental influences. This is verified by quality controls consisting of alternate climate and salt spray testing according to DIN EN ISO 9227 and is certified by tests on a regular basis. Winkhaus also carries out tests in outside areas, thus testing component behaviour under realistic conditions. This enables Winkhaus to offer a ten-year warranty for functions and surfaces.

Effective security

Thanks to this unique modular system, any window can be modified to achieve the required security standard - easily, quickly and cost-efficiently. There is no need for custom parts. Depending on the number and type of keeps, various security levels are achievable using the same platform. At our works, comprehensive and strict tests - along with ongoing functional monitoring - ensure maximum security for customers. Approval marks and certificates by independent test authorities confirm our results. You can therefore rely on activPilot meeting customer requirements for a secure fitting system. Locking bolts are made of high-strength steel; even standard types guarantee effective basic security. Depending on the number and type of keeps, the fitting system can be enhanced for compliance with stricter security classes - including burglar protection to DIN V ENV 1627-1630, RC2.

Winkhaus has successfully passed the demanding QM 328 certification.

activPilot fittings from Winkhaus are certified in accordance with QM 328. The turn-only and turn-tilt fittings for windows and patio doors undergo a large number of tests in this stringent certification programme, which verifies aspects such as durability and quality control mechanisms. The certificate stands as a testament to Winkhaus' long tradition in high quality products.

Quality standard

The Winkhaus group successfully passed a group certification of production sites according to DIN EN ISO 9001:2015 / DIN EN ISO 50001:2011.

The group certification ensures that we use the same criteria and procedures in all Winkhaus subsidiaries and thus we can always offer consistent quality for our customers.



Endurance test

Winkhaus activPilot is certified in accordance with EN 13126-8 (endurance test for turn-only and turn-tilt fittings) and EN 1191 (endurance test for windows and doors). The fitting thus complies with EN standards. Winkhaus' own permanent control in accordance with established production control guidelines as well as regular external monitoring by ift Rosenheim ensure outstanding product quality guaranteed on a long-term basis.

The activPilot Concept fitting series was tested for sash weights of up to 130kg, for activPilot Select up to 150 kg and for activPilot Comfort up to 100 kg. They clearly exceeded the load values required in the test. As a result, these fittings may now bear the ift Quality Certification Mark.

Your partner for service

Our services are solution-orientated, reliable and precisely geared to match your requirements - just as you would expect from your partner. We are at your disposal whenever you need us. With application engineers on site, professional help from our product data service and innovative software solutions to help optimise your workflows, we ensure you are able to work as you require and also broaden your professional service capabilities. What's more, our comprehensive product information system and sophisticated logistics guarantee fast delivery any time you need it.

Proper screw fixing in terms of load of security-relevant fitting components

In order to ensure the endurance and operating safety of windows and balcony doors over their expected service life, major importance must be attached to the installation of security-relevant fitting components!

Manufacturers of windows and balcony doors are responsible for fixing the fitting elements on the sash and the frame in a professional way and they must make sure that the specifications are adhered to.

Important: Follow these guidelines! Always use screws that are long enough to bear the loads. We recommend you to fix the corner and shear hinge screws in the steel reinforcement of the PVC-U window.

Basic technical features of the activPilot fitting system

In the following section you will find the general features that apply to all activPilot fitting components in the sash area, unless otherwise described on the corresponding product pages.

- Face plate width of sash fitting parts: 16 mm
- Overlapping system linkage without connecting plates
- Delivery state of sash fitting parts: centre fixed in turn position
- Safety locking pin as an adjustable octagonal bolt
- Sash fitting parts can be used right/left, unless otherwise stated.

Zertifikat / Certificate



Zertifikatsnr. / Certificate No.: 228-7019950-1-17

Dreh- und Drehkippsbeschläge für Fenster und Fenstertüren Turn and tilt-turn hardware for windows and casement doors

| | |
|--|--|
| Produkt <i>product</i> | activPilot, proPilot |
| max. Flügelgewicht <i>max. casement weight</i> | max 200 kg |
| Einsatzbereich <i>field of application</i> | Systeme mit entsprechender Beschlagaufnahme <i>Systems with suitable hardware groove</i> |
| Hersteller <i>manufacturer</i> | Aug. Winkhaus GmbH & Co. KG August-Winkhaus-Str. 31, D 48291 Telgte |
| Produktionsstandort <i>production site</i> | Aug. Winkhaus GmbH & Co. KG August-Winkhaus-Str. 31, D 48291 Telgte |



Mit diesem Zertifikat wird bescheinigt, dass das benannte Bauprodukt den Anforderungen des zugrundeliegenden ift-Zertifizierungsprogramms in der aktuellen Fassung entspricht.

- Erstellung von Produktfamilien des aufgeführten Bauproduktes und Erstprüfung durch eine akkreditierte Prüfstelle nach EN 13126-8:2017 unter Berücksichtigung der Anwendungsdiagramme
- Einführung und Aufrechterhaltung einer werkseigenen Produktionskontrolle durch den Hersteller
- Erstinspektion des Werkes und der werkseigenen Produktionskontrolle durch ift-Q-Zert
- kontinuierliche Fremdüberwachung des Werkes und der werkseigenen Produktionskontrolle durch ift-Q-Zert

Dieses Zertifikat wurde erstmals am 18. November 2008 ausgestellt und gilt 5 Jahre, wenn sich zwischenzeitlich die Festlegungen in der oben angeführten technischen Spezifikation oder die Herstellbedingungen im Werk oder in der werkseigenen Produktionskontrolle selbst nicht wesentlich verändert haben.

Das Zertifikat darf nur unverändert vervielfältigt werden. Alle Änderungen der Voraussetzungen für die Zertifizierung sind dem ift-Q-Zert mit den erforderlichen Nachweisen unverzüglich schriftlich anzuzeigen.

Das Unternehmen ist berechtigt, das benannte Bauprodukt gemäß der ift-Zeichensatzung mit dem „ift-zertifiziert“-Zeichen zu kennzeichnen.

Dieses Zertifikat enthält 2 Anlage/n.

This certificate attests that the building product mentioned fulfils the requirements of the underlying ift-certification scheme in its current version.

- compilation of product families of the building product listed and initial type-testing by an accredited testing body as per EN 13126:8:2017 based on the application diagrams
- implementation and maintenance of a factory production control by the manufacturer
- initial inspection of the production site and the factory production control by ift-Q-Zert
- continuous third-party control of the production site and the factory production control by ift-Q-Zert

This certificate was first issued on 18. November 2008 and will remain valid for 5 years, as long as neither the conditions laid down in the technical specification listed above nor the manufacturing conditions in the production site nor the factory production control itself are modified significantly.

The reproduction of the certificate without any change from the original is permitted. Any changes to the prerequisites applicable to certification shall be immediately communicated in writing to ift-Q-Zert accompanied by the necessary evidence.

The company is authorized to affix the "ift-certified"-mark to the building product mentioned according to the ift-rules for use of the "ift-certified"-mark.

This certificate contains 2 annexes.

Grundlage(n) / Basis:

ift-Zertifizierungsprogramm für Beschläge
ift-certification scheme for hardware (QM 328)
Ausgabe/issue 2018

EN 1191
EN 12400
bis Klasse 3
up to class 3



Dauerfunktion
resistance to repeated opening and closing

EN ISO 9227

EN 1670

bis Klasse 5
up to class 5



Korrosionsschutz
corrosion protection

ift Rosenheim
25. März 2019

Christian Kehrer

Christian Kehrer
Leiter der ift-Zertifizierungs- und Überwachungsstelle
Head of ift Certification and Surveillance



Ulrich Sieberath

Prof. Ulrich Sieberath
Institutsleiter
Director of Institute

228 7019950

Gültig bis /
Valid until:

10. Oktober 2023

2018-01 / 797



www.ift-rosenheim.de

ift Rosenheim GmbH
Theodor-Gietl-Str. 7-9
D-83026 Rosenheim

Kontakt
Tel.: +49 8031 261-0
Fax: +49 8031 261-290
www.ift-rosenheim.de

Prüfung und Kalibrierung – EN ISO/IEC 17025
Inspektion – EN ISO/IEC 17020
Zertifizierung Produkte – EN ISO/IEC 17085
Zertifizierung Managementsysteme – EN ISO/IEC 17021

Notified Body 0757
PUZ-Stelle: BAY 18

DAKKS
Deutsche
Akkreditierungsstelle
D-ZE-11349-01-00

Anlage / annex 1
 Hersteller / manufacturer:
 Aug. Winkhaus GmbH & Co. KG
 Ausgabedatum / date of issue: 25. März 2019



Zertifikatsnr. / Certificate No.: 228-7019950-1-17

In der Zertifizierung enthaltene Produktfamilien für Fenster- und Fenstertürsysteme mit geeigneter Beschlagsaufnahme.

Product families for window and casement door systems with groove designed for accommodation of hardware, covered by certification.

| lfd. Nr./ no. | Ausführung Bandscheitel/ type hinge side | Ausführung Flügelbeschlag/ type casement hardware | Beschreibung der Ausführung der blendrahmenseitigen Beschlagsausführung detail description of frame member hardware type | | | | Klassifizierung nach EN 13126-8:2017 classification as per EN 13126-8:2017 | | | |
|------------------|---|--|--|-----------------------------------|--------------------------|---------------------------|---|-----------------------------|---|--|
| | | | Winkelband/ top stay connecting part | Scherenlager/ stay arm support | Eckband/ corner hinge | Ecklager/ corner pivot | 1 Dauerfunktionsfähigkeit/ durability | 2 Masse (in kg)/ mass | 3 Korrosionsbeständigkeit/ corrosion resistance | 4 Prüfgrößen (in mm)/ test sizes |
| 1 | activPilot K 100 | activPilot K 100 | SK2.20-13 | SL.KS.3-6 | FL.K. 20-6-20 | EL.K. 6-3-16 | H2 | 100 | 5 | 1300 mm x 1200 mm |
| 2 | activPilot K 100 | activPilot K 100 | SK2.20-13 | SL.KS.3-6 | FL.K. 20-6-20 | EL.K. 6-3-16 | H2 | 100 | 5 | 900 mm x 2300 mm |
| 3 | activPilot K 130 S | activPilot K 130 S | SK2.20-13 | SL.K.3-6.130 | FL.K. 20-6-28.130 | ESV 6-3-16 | H3 | 100 | 5 | 1300 mm x 1200 mm |
| 4 | activPilot Comfort PADK 100 | activPilot Comfort PADK 100 | SK2.PA.20-13 | SL.KS.3-6 | FL.E.FWPA 20-13 | ESV 6-3-16 | H2 | 100 | 5 | 1300 mm x 1200 mm |
| 5 | activPilot Comfort PADK 100 | activPilot Comfort PADK 100 | SK2.PA.20-13 | SL.KS.3-6 | FL.E.FWPA 20-13 | ESV 6-3-16 | H2 | 100 | 5 | 900 mm x 2300 mm |
| 6 | activPilot Comfort PADM 100 | activPilot Comfort PADM 100 | SK2.PAD. 20-13 | SL.KS.3-6 | FL.E.FPAD 20-13 | ESV 6-3-16 | H2 | 100 | 5 | 1300 mm x 1200 mm |
| 7 | activPilot Comfort PADM 100 | activPilot Comfort PADM 100 | SK2.PAD. 20-13 | SL.KS.3-6 | FL.E.FPAD 20-13 | ESV 6-3-16 | H2 | 100 | 5 | 900 mm x 2300 mm |
| 8 | activPilot C 130 | activPilot C 130 | SC2.20-13 | SL.C.3-6 | FL.C.W. 20-13 | EL.CS. 6-3-22 | H3 | 130 | 5 | 1400 mm x 1550 mm |
| 9 | activPilot K 130 | activPilot K 130 | SK2.20-13 | SL.KB.3-6 | FWW 20-13 | ESVW 6-3-16 | H2 | 130 | 5 | 1300 mm x 1200 mm |

Anlage / annex 1
 Hersteller / manufacturer:
 Aug. Winkhaus GmbH & Co. KG
 Ausgabedatum / date of issue: 25. März 2019



Zertifikatsnr. / Certificate No.: 228-7019950-1-17

| | | | | | | | | | | |
|----|----------------------------|----------------------------|--------------------|-----------------|----------------------|--|----|-----|---|-------------------|
| 10 | activPilot K 130 | activPilot K 130 | SK2.20-13 | SL.KB.3-6 | FWW 20-13 | ESVW 6-3-16 | H2 | 130 | 5 | 900 mm x 2300 mm |
| 11 | activPilot ALU 130 | activPilot ALU 130 | SK2.20-13 | SL.KB.3-6 | FWV 20-13 | ESVW 6-3-16 | H2 | 130 | 5 | 1300 mm x 1200 mm |
| 12 | activPilot ALU 130 | activPilot ALU 130 | SK2.20-13 | SL.KB.3-6 | FWW 20-13 | ESVW 6-3-16 | H2 | 130 | 5 | 900 mm x 2300 mm |
| 13 | activPilot K 130 S | activPilot K 130 S | SK2.20-13 | SL.K.3-6.130 | FL.K. 20-6-28.130 | ESV 6-3-16 | H2 | 130 | 5 | 1300 mm x 1200 mm |
| 14 | activPilot K 130 S | activPilot K 130 S | SK2.20-13 | SL.K.3-6.130 | FL.K. 20-6-28.130 | ESV 6-3-16 | H2 | 130 | 5 | 900 mm x 2300 mm |
| 15 | activPilot H 130 | activPilot H 130 | SH2.T. 18-13-12 | SL.HT.18-12 | FL.HT. 18-13-12 | EL.HT.Z. 18-12 | H3 | 130 | 5 | 1300 mm x 1200 mm |
| 16 | activPilot H 150 | activPilot H 150 | SH2.T. 18-13-12 | SL.HT.18-12 | FL.HT. 18-13-12 | EL.HT.Z. 18-12 | H3 | 150 | 5 | 900 mm x 2300 mm |
| 17 | activPilot Giant | activPilot Giant | SXL.20-13 | SL.XL | FL.XL | EL.XL | H3 | 200 | 5 | 1550 mm x 1400 mm |
| 18 | activPilot Giant | activPilot Giant | SXL.20-13 | SL.XL | FL.XL | EL.XL | H2 | 200 | 5 | 900 mm x 2300 mm |
| 19 | activPilot Select K 100 | activPilot Select K 100 | SK.SE | ohne without | FL.SE | EL.K.SE | H2 | 100 | 5 | 1300 mm x 1200 mm |
| 20 | activPilot Select H 130 | activPilot Select H 130 | SH.SE. 20-9.Z. | ohne without | FL.SE | EL.H.SE. 20-9.Z. mit/with FLS.SE | H2 | 130 | 5 | 1300 mm x 1200 mm |
| 21 | activPilot Topstar | activPilot Topstar | SH.IF.24-13 | ohne without | FL.IF | EL.H.IF. 24-13 | H2 | 130 | 5 | 1300 mm x 1200 mm |

Anlage / annex 1
 Hersteller / manufacturer:
 Ausgabedatum / date of issue:

Seite / page 3 von / of 3
 Aug. Winkhaus GmbH & Co. KG
 25. März 2019



Zertifikatsnr. / Certificate No.: 228-7019950-1-17

| | | | | | | | | | | |
|----|---------------------------|---------------------------|--------------|--------------|--------------|-------------------------------|----|-----|---|-------------------|
| 22 | activPilot Topstar | activPilot Topstar | SH.IF.24-13 | ohne without | FL.IF | EL.H.IF.24-13 | H2 | 130 | 5 | 900 mm x 2300 mm |
| 23 | activPilot Select K 150 | activPilot Select K 150 | SK.SE | ohne without | FL.SE | EL.K.SE mit/with FLS.SE | H2 | 150 | 5 | 1550 mm x 1400 mm |
| 24 | activPilot Select K 150 | activPilot Select K 150 | SK.SE | ohne without | FL.SE | EL.K.SE mit/with FLS.SE | H2 | 150 | 5 | 900 mm x 2300 mm |
| 25 | activPilot Select ALU 150 | activPilot Select ALU 150 | SK.SE | ohne without | FL.SE | EL.K.SE mit/with FLS.SE | H2 | 150 | 5 | 1550 mm x 1400 mm |
| 26 | activPilot Select H 150 | activPilot Select H 150 | SH.SE.29-13 | ohne without | FL.SE | EL.H.SE.29-13 mit/with FLS.SE | H2 | 150 | 5 | 1550 mm x 1400 mm |
| 27 | proPilot | proPilot | SK.U.2.20-13 | SL.K.U.3-3 | FL.K.U.6 | EL.K.U.3-3 | H2 | 70 | 4 | 1300 mm x 1200 mm |
| 28 | proPilot | proPilot | SK.U.2.20-13 | SL.K.U.3-3 | FL.K.U.6.100 | EL.K.U.3-3 | H2 | 100 | 4 | 1300 mm x 1200 mm |
| 29 | activPilot C 150 | activPilot C 150 | SC2.20-13 | SL.C.3-6 | FL.C-W-20-13 | EL.CS.6-3-22 | H3 | 150 | 5 | 900 mm x 2300 mm |
| 30 | activPilot C 150 | activPilot C 150 | SC2.20-13 | SL.C.3-6 | FL.C.20-6-28 | EL.C.6-3-22 | H3 | 150 | 5 | 900 mm x 2300 mm |
| 31 | activPilot C 130 | activPilot C 130 | SC2.20-13 | SL.C.3-6 | FL.C.20-6-28 | EL.C.6-3-22 | H3 | 130 | 5 | 1400 mm 1550 mm |

Die Ergebnisse sind auf folgende Ausführungsvarianten übertragbar: Beschlagsausführung links/rechts, alle zulässigen Größen gemäß Anwendungsdiagramm sowie andere Falz- und Profillegeometrien. Die technische Dokumentation des Beschlagherstellers, insbesondere die entsprechenden Anwendungsdiagramme, ist zu beachten.

The results can be applied to the following design variants: hardware type left/right, all permissible sizes in accordance with the application diagram as well as other rebate and profile geometries. Observe technical documents of hardware manufacturer, in particular the relevant diagrams.

Obligations regarding information and instructions

This document brings together important information and details regarding different fittings and their further processing. The information is particularly intended for window and balcony door manufacturers and fitting and structural component retailers. Accidents and physical damage can be avoided if you observe the information contained in this information. For this reason, you must always ensure that you pass on the relevant documents when you hand fittings over to somebody else. Information and documents should be handed over in printed format, on a CD ROM or online, for example.

Guidelines for the use of locking systems and fittings

Gütegemeinschaft Schlösser und Beschläge e.V., Velbert issues guidelines offering assistance for the use of locking systems and fittings for windows, doors and patio doors. These guidelines are established in cooperation with the trade association of the locks and fittings industry in Velbert as well as the testing institute PIV which is also based in Velbert. If required, they are agreed with the VFF technical committee and ift Rosenheim. As a result the experience and test findings of several decades are considered.

The guidelines provide information about the intended use and maintenance of fittings for windows and patio doors. It is mandatory to observe these guidelines.

The current guidelines can be accessed in different languages at the following Internet address: <http://www.beschlagindustrie.de/ggsb/richtlinien.asp>



As an alternative to using the www address, you can also scan the QR Code with your smartphone!

Follow this link to find the applicable and binding guidelines on the following topics:

- VHBH - Fittings for windows and patio doors [with guidelines / instructions on the product and liability]
- VHBE - Fittings for windows and patio doors [with guidelines / instructions for end users]
- TBDK - Attachment of supporting fitting components of turn and turn-tilt fittings [with definitions of turn and turn-tilt fittings as well as their possible mounting positions]
- FPKF - Safety and cleaning shears for tilt sashes and tilting fanlights [use of safety and cleaning shears]
- FPDF - Sash limiters for variable turn position of sashes [sash limiters controlled by central locking system - definitions and tests]



The VHBH guideline among others contains the chapter “Obligation to give instructions”. A schematic illustration shows the documents and information to be submitted to the different target groups for respecting the instructions obligation. The building owner must pass on the documents defined in the chapter “Obligation to give instructions” to the end user.



Gütegemeinschaft Schlösser und Beschläge e.V.

Richtlinie: TBDK

ORIGINALFASSUNG Ausgabe: 2014-02-05

Richtlinie

Befestigung tragender Beschlagteile von Dreh- und Drehkipp-Beschlägen
mit Definitionen zu Dreh- und Drehkipp-Beschlägen sowie deren möglichen Einbautagen

Inhalt:

| | | |
|---|--|----|
| 1 | Vorwort | 3 |
| 2 | Anwendungsbereich | 3 |
| 3 | Begriffe | 4 |
| 4 | Dauerfunktionsfähigkeit – Grenzen der Richtlinie | 7 |
| 5 | Empfehlungen für die Befestigung | 9 |
| 6 | Durchführung der Prüfungen | 9 |
| 7 | Vorgaben zu den Prüfungen | 16 |
| 8 | Literaturhinweise | 22 |

Herausgeber:

Gütegemeinschaft Schlösser und Beschläge e.V.
 Offerstraße 12
 42551 Velbert
 Phone: +49 (0)2051 / 95 06 - 0
 Fax: +49 (0)2051 / 95 06 - 20
 www: [www: www.beschlagindustrie.de](http://www.beschlagindustrie.de)
www.beschlagindustrie.de/ggsb/richtlinien.asp

Hinweis

Technische Angaben und Empfehlungen dieser Richtlinie beruhen auf dem Kenntnisstand bei Drucklegung. Es gilt der Inhalt des „Disclaimer“ auf der o.g. Internet-Seite.

Richtlinie TBDK
1 / 23

Product liability guidelines

Turn and turn-tilt fittings for windows and patio doors

According to the current product liability legislation dealing with a manufacturer's liability for his products (§ 4 ProdHaftG) please observe the following information on turn and turn-tilt fittings for window and patio door sashes. The manufacturer will not accept any liability for noncompliance with these specifications.

1. Product information and intended use

Turn and turn-tilt fittings within the meaning of this definition are single handle turn-tilt fittings for windows and patio doors as used in building applications. They are used to bring window and window sashes into a turn position or into a tilt position limited by the shear version using a hand lever. Turn and turn-tilt fittings are used on vertically installed windows and patio doors made of wood, PVC-U, aluminium or steel and their corresponding material combinations. Conventional turn and turn-tilt fittings in the sense of this definition close/lock window and patio door sashes and bring them into different ventilation positions. As a rule, the counterforce of a seal must be overcome when closing. Uses deviating from this do not correspond to the intended use. Burglary-resistant windows and patio doors, windows and patio doors for damp rooms and those for use in environments with aggressive, corrosion-promoting air contents require fittings with performance characteristics coordinated and separately agreed for the respective application. Opened window and patio door sashes only achieve a shielding function and do not meet any requirements for joint tightness, watertightness, sound insulation, thermal insulation and burglary resistance. In wind and draughts, window and window sashes must be closed and locked. Wind and draught in the sense of this definition are present if the window or patio door sashes in one of the opening positions open or close automatically and uncontrollably due to air pressure or air suction. A fixed open position of window and patio door sashes can only be achieved with arresting additional fittings. The resistance to wind loads in closed and locked state depends on the respective constructions of windows and patio doors. If wind loads must be transferred in accordance with DIN EN 12210 (particularly test pressure p₃), suitable fitting combinations must be agreed in conjunction with the respective window construction and the frame material and agreed separately. In general, the turn and turn-tilt fittings can meet the requirements for barrier-free apartments in accordance with DIN 18025. However, this requires corresponding fitting combinations and assemblies in the windows and patio doors, which must be coordinated and agreed separately.

2. Misuse

Misuse – i.e. the use of a product in a manner contrary to the manufacturer's instructions – of turn-tilt fittings for windows and patio doors occurs

- if obstacles are placed in the opening area preventing the intended use.
- if sashes of windows / patio doors are pushed or hit against the window reveal, either contrary to the manufacturer's instructions or in an uncontrolled way (e.g. by wind), that the fittings, the frame materials or other individual parts of the window sash or the patio door sash are damaged or destructed or subsequent damage occurs
- if additional loads act on the sashes of windows or patio doors (e. g. children swinging on them).
- if someone grasps in the gap between the frame and sash when closing the window (risk of injury).

3. Liability

The respective overall fitting must be selected from the original Winkhaus activPilot fitting components range. Winkhaus accepts no liability if non-original or unauthorised system accessory parts are used.

Important: The screw / clamping connection of load-bearing fitting components, such as corner, shear and sash hinges must be designed according to the TBDK guidelines. Please adapt the fixing procedure of the fitting components to the load situation.

4. Product performance – Manufacturer's instructions for use

The maximum sash weights for the individual fitting versions may not be exceeded. The component with the lowest permissible loading capacity determines the maximum weight of the sash. Please observe the diagrams and component installation instructions.

4.1 Sash sizes and areas of application

The graphs in the application diagrams show the permitted sash rebate height to width ratios, as determined by different weights of glass and/or overall glass thickness. The resulting sash rebate dimensions or sash formats (portrait/landscape) as well as the maximum sash weight may under no circumstances be exceeded.

4.2 Application diagram for determination of the permissible sash sizes

The application diagrams for this fitting series for the determination of permissible sash sizes are described and explained separately on the following pages.

4.3 Composition of fittings

You must comply with the manufacturer's specifications regarding the configuration of fittings (e.g. the use of additional shears, the layout of fittings for burglary-resistant windows and patio door sashes, etc.).

5. Product maintenance

Security-relevant fitting parts are to be inspected at least once a year to check for wear and to ensure they are firmly secured in position. Fastening screws must be tightened and faulty components must be replaced as required. In addition, maintenance/cleaning work must be carried out at least once a year.

All mobile parts and locking points of fittings should be greased and tested for function.

Only oils and greases not affecting the materials of the fitting may be used.

The only cleaning and maintenance materials to be used are those which will not adversely affect the corrosion-resistant properties of the fittings components.



Adjustment work to the fittings – particularly in the area of the corner drive and the shears – as well as the replacement of parts and mounting and removal of opening sashes must be carried out by a trained specialist.

5.1 Maintaining surface quality

- The fittings and rebate spaces must be adequately ventilated, particularly during the construction stage, so that they are not exposed to the direct effects of moisture or condensation. It must be ensured in any case by appropriate measures that there is no possibility for (permanently) humid room air to condense in the rebate area.
- The fittings must be kept free from deposits and soiling due to building materials (building dust, gypsum plaster, cement etc.). Possible soiling from plaster, mortar etc. must be removed prior to bonding with water.
- Corrosive vapours (e.g. formic acid, acetic acid, ammonia, amine and ammonia compounds, aldehydes, phenols, chlorine, tannic acid etc.) combined with even a small amount of condensation can cause rapid corrosion of the fittings. Therefore, such evaporation in the area of the windows must be avoided at all costs.

- Furthermore no sealants that cure with acetic or other acids, or sealants containing any of the above-mentioned substances, must be used. Both direct contact with the sealant and vapours released from it can damage the surface.
- Only use a mild and pH neutral detergent in diluted form to clean the fittings. Under no circumstances use aggressive acidic cleaners or scouring agents containing the substances listed above.

6. Obligations regarding information and instructions

For the implementation of information and instruction obligations as well as for the maintenance work the following documents are available. They must be submitted to (intermediate) dealers and manufacturers and to the end customer.

Planning documentation

Product catalogues

Installation Instructions

Maintenance and care instructions as well as operating instructions

7. Use of type-related fittings











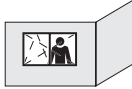

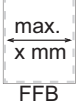

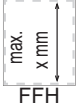

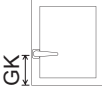
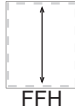
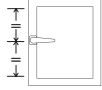



The variants for the individual fitting systems (e.g. tilt and top-hung sash fittings or parallel action fittings providing an additional ventilation position by means of a circumferential gap all around the sash) are to be handled accordingly with regard to product information and intended use, misuse, product performance, product maintenance, information and instruction obligations depending on the applicable characteristics.

8. Storage

Before the fitting components are assembled, they must be stored on a dry, protected and level surface.

1

Declaration of symbols

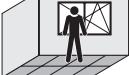
| | | | |
|---|--|---|---|
|  | Max. Sash weight: x kg |  | Exterior view |
|  | Max. Sash size: x m ² |  | Basic set of fittings |
|  | Max. Sash rebate width (FFB): x mm |  | Optional fittings |
|  | Max. Sash rebate height (FFH): x mm |  | Size-dependent fittings depending on sash rebate width (FFB) |
|  | Constant handle height |  | Size-dependent fittings depending on sash rebate height (FFH) |
|  | Central handle height |  | "TOP" marks the upper edge of the window. |
|  | Turn sash (D) |  | Pot hinge version |
|  | Turn-tilt sash (DK) |  | Rebate hinge version |
|  | Turn/Turn-tilt double sash (D/DK-Stulp) |  | Item for use on PVC-U windows |
|  | Turn or turn-tilt sash with parallel opening |  | Item for use on wooden windows with 12 mm airgap |
|  | Parallel action |  | Item for use on aluminium windows |
|  | Slide-tilt window |  | Component for use in threshold solutions |
|  | Interior view | | |

Packing key in the Winkhaus logistics system

The shipping units are configured in a way to enable you easy handling of our products in your works from small boxes to bulky pallets. For instance, we provide KLTs (small load carriers) in different sizes which are eco-friendly and facilitate logistics. The reusable packaging units, which can be stacked on a europallet, have a bar code and enable optimal stock organisation and easy transport to the relevant workstations.

The packaging used for the products in question can be found on the corresponding product pages.

- 

BL BL Goods packed in PE bags with bar code

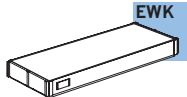

EWK EWK Disposable cardboard box E3, L6 or L7
- 

KT KT Goods packed in cardboard boxes with bar code

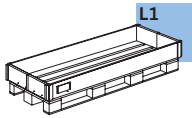

L1 L1 Reusable pallet I for long goods with frame and bar code
Pallet size 800 x 1,800 mm
- 

BD BD Tied goods with barcode

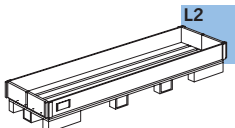

L2 L2 Reusable pallet II for long goods with frame and bar code
Pallet size 800 x 2,400 mm
- 

K3 K3 Small cardboard box with bar code. Dim: 395 x 295 x 205 mm

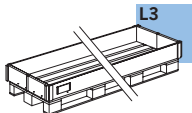

L3 L3 Reusable pallet III for long goods with frame and bar code
Pallet size 800 x 3,500 mm
- 

K4 K4 Big cardboard box with bar code. Dim: 595 x 395 x 205 mm

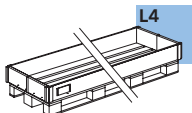

L4 L4 Reusable pallet IV for long goods with frame and bar code
Pallet size 800 x 4,200 mm
- 

KK KK Small KLT (small load carrier) 4321. Dim: 400 x 300 x 214 mm with cover, bar code, sealed, stackable

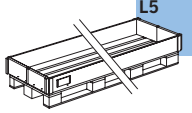

L5 L5 Reusable pallet V for long goods with frame and bar code
Pallet size 800 x 6,500 mm
- 

GK GK Big KLT (small load carrier) 6412. Dim: 600 x 400 x 214 mm with cover, bar code, sealed, stackable

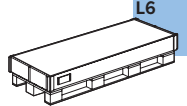

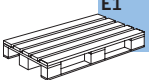

L6 L6 One-way pallet with cover box for long goods with bar code
Pallet size 800 x 1,800 mm
- 

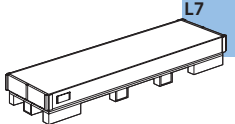
E1 E1 europallet with KLT. Pallet size 800 x 1,200 mm

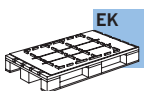

L7 L7 One-way pallet with cover box for long goods with bar code
Pallet size 800 x 2,400 mm
- 

E3 E3 One-way pallet with cover box and bar code
- 

EK EK Europallet with KLT and fixing plate (avoids shifting of goods)
Pallet size 800 x 1,200 mm
- 

EA EA Europallet with frame and bar code. Pallet size 800 x 1,200 mm

1

Glossary

| Code | | | |
|-------------------|---|--------------|---|
| | | GAMA | Drive rod, central handle position, lockable |
| | | GASK | Double sash drive rod, constant handle position |
| | | GASM | Double sash drive rod, central handle position |
| | | GAVM | Locking drive rod activPilot, central handle position |
| | | GG | Handle set |
| | | GK | Constant handle position |
| | | GRT.RB | Round arch set |
| | | HC | Timber windows, rebate version |
| | | HFG | Window Handle Case HFG |
| | | HT | Timber windows, pot hinge version |
| | | IF | activPilot Topstar |
| | | K.EL | Corner hinge cap |
| | | K.FL | Sash hinge cover |
| | | K.SB | Shear hinge cap, timber |
| | | K.SK | Shear hinge insert cap |
| | | K.SL | Shear hinge cover |
| | | KB | Tilt hinge |
| | | KBG | Tilt limiter |
| | | KE | Coupling element |
| | | KLB | Tilt hinge insert |
| | | KR | Shootbolt |
| | | KUE-T1 | Cable transition, separable |
| | | LE.B | Drill jig |
| | | LE.FR | Milling jig |
| | | LE.N | Jig |
| | | LIN AP/FS | Ruler of fittings press |
| | | LM-RG | Round handle |
| | | M | Interlocking rod |
| | | MK | Interlocking rod, extendable |
| | | MS.SO | Interlocking rod, double sash, keep top |
| | | MS.SU | Interlocking rod, double sash, keep bottom |
| | | MSLOS | Variable tilt device top rod |
| | | NML | Groove centre position |
| | | OBV | Opening limiter |
| | | OS | Top rod |
| | | OS...PA... | Top rod, PADK |
| | | OS. ...E | Top rod (turn before tilt) |
| | | OS.A | Screw clip |
| | | PA | Parallel action |
| | | PAD | Parallel action, turn |
| | | PADK | Parallel action, turn-tilt |
| | | RA.DB.SE | Frame connection turn limiter |
| | | RT.DFE-TFE | Frame part, dual/triple function element |
| | | RT.DFE-TFE.S | Frame part, dual/triple function element, double-sash windows |
| | | RT.MSL | Frame part, variable tilt device |
| AB.G.D | Drilling protection | | |
| ADS | Cover strip | | |
| ADP | Adapter | | |
| AKR | Automatic shootbolt | | |
| AL... | Support plate | | |
| ANS | Mounting element | | |
| AP.HH | Fitting punch, lever | | |
| AP...SE | Adapter plate, activPilot Select | | |
| AS.DSL | Mini ventilation unit (turn position) | | |
| AS.SBA | Mini vent keep | | |
| ASP ER-A | End plate | | |
| ASS AR | Connecting rail | | |
| AWDR | Stroke limiter | | |
| BK | Balcony door catch | | |
| BK.KR | Catch bolt | | |
| BO | Catch bolt | | |
| BS | Threshold | | |
| BST AP/FS | Fittings punch | | |
| D | Backset | | |
| DB | Turn limiter | | |
| DBG | Turn limiter | | |
| DFE | Dual function element | | |
| DL | Turn hinge insert | | |
| DL...ET | Turn hinge, 1 piece | | |
| DLW ERW | Turn hinge bracket | | |
| DML | Turn middle hinge | | |
| DS | Window lock | | |
| E | Corner drive | | |
| E1.A | Corner drive for studio windows | | |
| E1.MSL | Corner drive with variable tilt device | | |
| E1.SBS | Corner drive for double-sash window | | |
| EL | Corner hinges | | |
| ELK | Corner hinge cap | | |
| ESV/ESVW | Corner hinges | | |
| FBP | Window limiter | | |
| FH ... | Sash lifter | | |
| FK-F | Sash hinge (with turn restriction) | | |
| FL | Sash hinges | | |
| FL...PADS | Sash hinge, PADS | | |
| FL...PAD/ PADM | Sash hinge PAD/PADM | | |
| FL...PADK | Sash hinge, PADK | | |
| FLK | Sash hinge cover | | |
| FLS.SE | Sash hinge rail, activPilot Select | | |
| FSA | Fail safe device FSA | | |
| FSF | Fail safe device FSF | | |
| FSR | Rebate shear | | |
| FT | Spacer | | |
| FWV | Sash hinge, rebate hinge | | |
| GAK | Drive rod, constant handle position | | |
| GAKA | Drive rod, constant handle position, lockable | | |
| GAM | Drive rod, central handle position | | |

| | | Item description | |
|-------------------|--|------------------|---------------------------------------|
| S.FL | Sash hinge plug | | |
| SA | Shootbolt keeps | | |
| SA.IF | Shear Topstar aluminium | | |
| SB SZV | Keep, claw bolt | ...LS | Fitting direction left |
| SBA... | Keep, contact pressure | ...RS | Fitting direction right |
| SBA...T | Mini vent keep | ...AGR | anthracite grey (similar to RAL 7016) |
| SBK | Security tilt keep | ...BR | brown (similar to RAL 8019) |
| SBK...E | Tilt keep (tilt before turn) | ...BZ-AM | bronze - antique brass |
| SBK...PA | Tilt keep (with slider), PADK | ...BZ-CU | bronze - coppery |
| SBK...SP | Security tilt keep with gap locking device | ...BZ-RB | bronze - red brown |
| | | ...CW | cream white (similar to RAL 9001) |
| | | ...EV1 | anodised silver |
| SBS... | Security keep | ...F1 | silver coloured |
| SBS...PA | Security keep, PADK | ...F1-elox | (similar to F1) anodised silver |
| SBS...PAB | Security keep PAB, PADK | ...F3 | gold coloured |
| SBS...PAD | Security keep PAD/PADM | ...F3-MG | gold mat |
| SC/SK | Shears | ...F9 | titanium coloured |
| SC...A/SK...A | Shear studio window | ...LBR | clay brown |
| SC...E/SK...E | Shear (tilt before turn) | ...PW | pearl white (similar to RAL 1013) |
| SC...PA.../SK... | Shear, PADK | ...SG | silver-grey (similar to RAL 7001) |
| PA... | | ...SGB | grey (similar to RAL 9006) |
| SC...PAD.../SK... | Shear PAD | ...SGR | grey (similar to RAL 7037) |
| PAD... | | ...SL | silver look (zinc galvanised) |
| SCO/SKK | Shear, without turn restriction | ...SW | jet black |
| SE | activPilot Select | ...WS | white (similar to RAL 9016) |
| SH...T | Shear, pot hinge | | |
| SH.IF | Shear Topstar wood | | |
| SK.IF | Shear Topstar PVC-U | | |
| SL | Shear hinge | | |
| SL.HC | Shear hinge, timber rebate hinge | | |
| SLK | Shear hinge cap, rebate hinge | | |
| SNH | Faceplate fastener | | |
| SP R | Faceplate | | |
| SR | Control unit SR | | |
| SZP | Geared cover plate | | |
| | | | |
| TFE | Triple function element | | |
| | | | |
| UEB | Overlap | | |
| UF | Packer | | |
| | | | |
| V | Distance between locking points | | |
| VBST | Connection piece | | |
| V.AK | Extension rod | | |
| VK.AK | Extension rod, extendable | | |
| VS R | Connection rod | | |
| VS RB | Connection rod round-arch window | | |
| | | | |
| XL | Components from activPilot Giant range | | |
| | | | |
| ZSR | Additional shear | | |
| ZSRE | Additional shear (tilt before turn) | | |
| ZSS | Anti-slam device | | |
| ZV... | Claw bolt | | |
| ZV.RT | Claw bolt, frame part | | |

1

activPilot Comfort, the fitting system for healthy and energy-efficient ventilation.

In order to meet the increased demands put on standards and energy-efficient indoor ventilation, Winkhaus has developed an innovative and unique fitting system, activPilot Comfort.

Parallel action means a circumferential ventilation gap up to 6 mm between the sash and the frame is created, thus enabling a natural exchange of air.

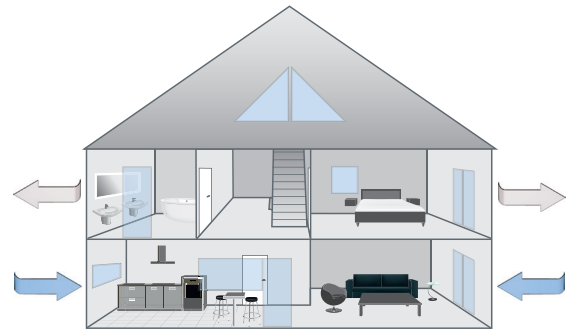
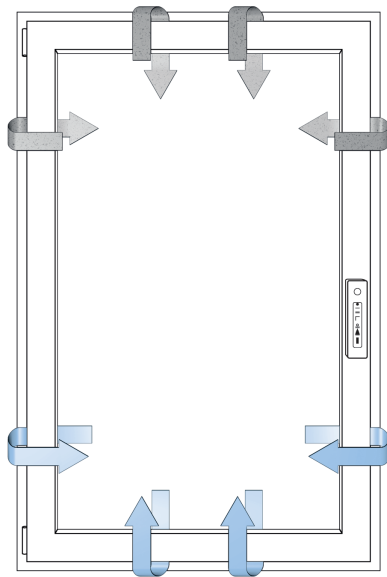

Rooms must be ventilated

We create moisture in our houses and apartments every day – for example caused by cooking, taking showers, breathing or flower watering. Approx. 2 - 3 litres a day evaporate per capita. If the moisture remains in the home, this may result in structural damage, mould and a poor indoor climate.

For the ambient air can only absorb a limited amount of moisture, depending on the temperature. The warmer the air, the more moisture it absorbs. When the air cools down, it releases the moisture. Condensation therefore forms on cold surfaces such as window panes or cool outer walls. Mould can form, especially in corners of rooms.

Apart from the moisture, harmful substances evaporating from wallpapers, carpets, wall paint and furniture may accumulate in the air. Humidity and harmful substances can only be discharged from the rooms if these are correctly ventilated.

Modern living space presents new challenges

While energy efficiency of living spaces is rising, the requirements set on the tenants' ventilation behaviour is too. In former times houses were far less "tight" than today. Stale room air was able to escape continuously through the building envelope, exterior doors and windows. Fresh outside air entered through tiny cracks and crevices without any action on the part of the residents. Any condensation water was only deposited on single-glazed windows and quickly disappeared due to the constant exchange of air.

Nowadays, buildings are constructed or refurbished according to the new energy saving regulations (EnEV). Buildings are almost completely air-tight. For this reason it is the tenants themselves who must take care to ventilate their homes in the right way. However, due to a lack of time or the high energy loss caused by open windows, this is often neglected.

Burglar-resistant ventilation.

activPilot octagonal locking bolts in combination with steel mini vent keeps offer an increased basic security, even in the standard version.

The special feature: The parallel opening position (rectangular windows) enables the same burglar resistance as the closed position of the window, burglar resistance to DIN EN 1627-1630 up to resistance class RC2. The innovation: Burglar-resistant ventilation!

Energy-efficient ventilation.

When windows are placed in a parallel position, fresh outdoor air flows into the room more slowly and more evenly. Air is thus warmed to room temperature more quickly and energy losses are reduced considerably (see graphic).

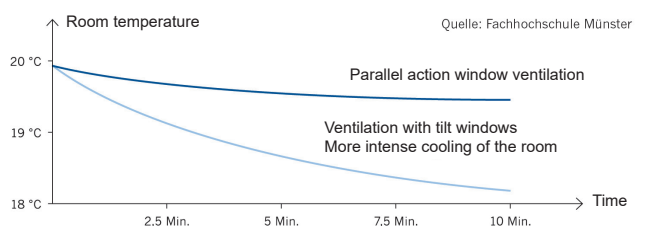

In order to ascertain the amount of air that can be exchanged against the pressure difference, you can use the chart to determine the volume flow per running metre (sash rebate sizes).

Example:

With a pressure difference of 2 Pa there is an exchange of air of approx. 10.7 m³/h per running metre. This means that the air that is exchanged through a window 1 x 1 m amounts to 42.5 m³/h.



The information given refers to a ventilation gap of approx. 6 mm.

Wind velocities

| Pa | m/sek | km/h | Wind strength in BF |
|-----|-------|-------|---------------------|
| 2 | 1,8 | 6,6 | 2 |
| 3 | 2,2 | 8,1 | |
| 4 | 2,6 | 9,3 | |
| 5 | 2,9 | 10,4 | |
| 8 | 3,5 | 12,7 | 3 |
| 10 | 4,1 | 14,7 | |
| 15 | 5,0 | 18,0 | |
| 20 | 5,8 | 20,8 | 4 |
| 50 | 9,1 | 32,9 | 5 |
| 100 | 12,9 | 46,5 | 6 |
| 300 | 22,4 | 80,5 | 9 |
| 600 | 31,6 | 113,8 | 11 |

Wind load zones in Germany

Dark blue areas: areas of strong wind

Light blue areas: areas of low wind

Further information on the subject of wind loads in Germany can be found here:

ift Rosenheim, <http://www.ift-rosenheim.de/rechentools.php> or DIN 1946-6 ventilation of apartments or Winkhaus ventilation tool

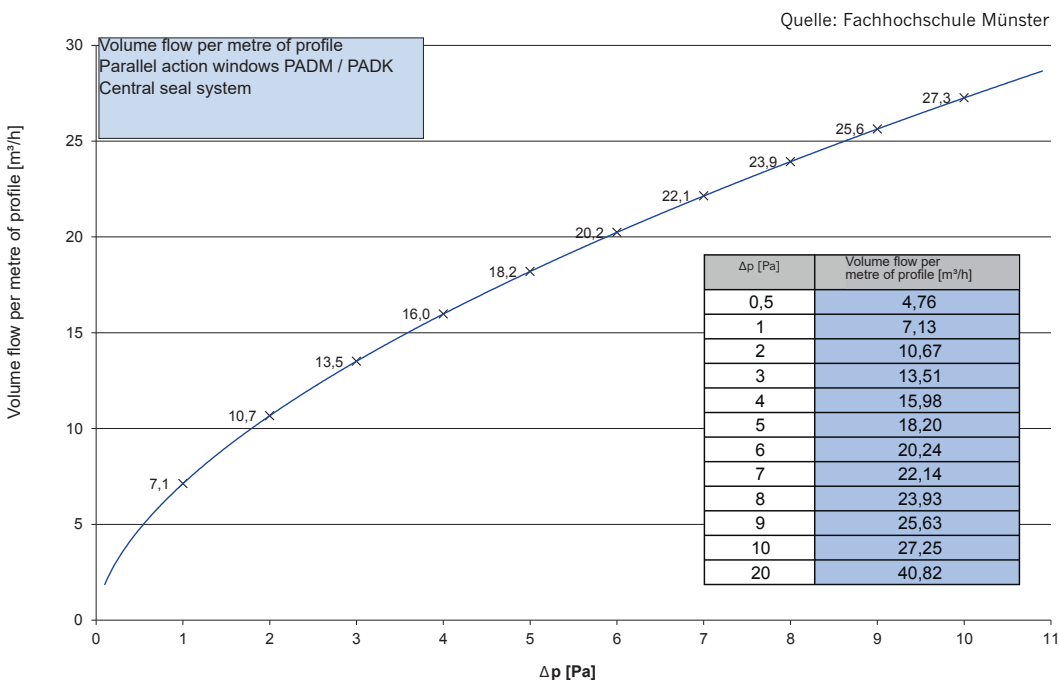
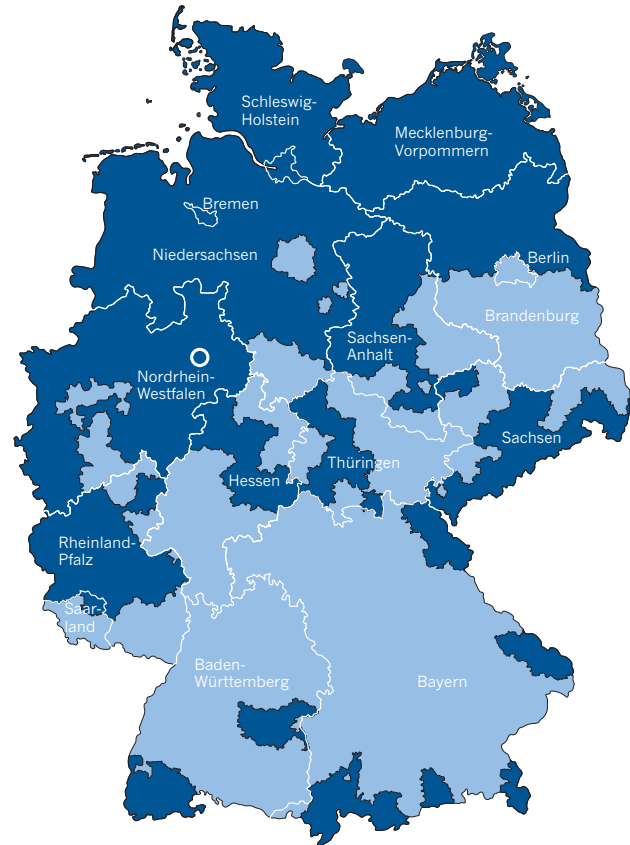

| | | Page | |
|-----------|------------------------------------|-----------|-----------|
| 1 | General product information | 19 - 21 | 1 |
| 2 | Lists of Fittings | 22 - 35 | 2 |
| 3 | Drive rods | 36 - 49 | 3 |
| 4 | Corner drives | 50 - 56 | 4 |
| 5 | Top rods | 57 - 58 | 5 |
| 6 | Sash hinges/Corner hinges | 59 - 64 | 6 |
| 7 | Shears/Shear hinges | 65 - 67 | 7 |
| 8 | Turn hinges/Tilt hinges | 68 | 8 |
| 9 | Extension rods | 69 - 71 | 9 |
| 10 | Accessories | 72 - 77 | 10 |
| 11 | Frame parts | 78 - 84 | 11 |
| 12 | Mounting accessories | 85 - 88 | 12 |
| 13 | Installation Instructions | 89 - 117 | 13 |
| 14 | Adjustment/maintenance | 118 - 122 | 14 |
| 15 | Installation drawings | 123 - 124 | 15 |
| 16 | activPilot Comfort PADM | 125 - 189 | 16 |
| 17 | activPilot Comfort PADS | 191 - 252 | 17 |
| 18 | activPilot Comfort PAD | 253 - 307 | 18 |

1

activPilot Comfort PADK

Turn-tilt fittings with parallel action.

Compared with conventional turn-tilt windows, activPilot Comfort PADK offers another opening dimension in addition to the “turn” and “tilt” opening positions: “parallel action”. Bringing a window into this position is child’s play. All you have to do is turn the window handle 180° – and you’re done. The window sash is then placed parallel to the frame. Winkhaus has already successfully introduced the parallel action system with the autoPilot turn-tilt fitting system. This technology has now been adopted and further developed for the activPilot Comfort PADK product segment.

As in activPilot Comfort, the window sash is placed parallel to the frame. This leaves a 6 mm air gap, which guarantees a natural and secure ventilation in all weathers. The natural exchange of air thus ensures a healthy indoor climate. activPilot Comfort PADK maintains ventilation via fully-opened sashes or ventilation via the usual window functions.

The special feature: This position offers the same protection from burglary as in the close state – burglary-resistance according to DIN EN 1627 – 1630 up to resistance class RC2 is possible. The innovation: Burglary-resistant ventilation!

We intentionally took a different path in the development of the activPilot Comfort PADK. The tilt-first (tilt before turn) operating sequence has the advantage that the fitting is extremely smooth-running and enables high production tolerances. This operating sequence offers additional security and is frequently used in nurseries, single homes, multi-family houses and residential homes for the elderly.

The special aspect here is the double function of the diagonal handle position:

If the handle is moved to the crosswise position from below, the fitting is in the tilt position. The sash is brought into the parallel position by turning further by 90° to the 180° position. If the handle is turned back to the 90° position, the window sash can be moved to the turn position. To close the window, the handle must be turned downwards to the initial position.

Another benefit of activPilot Comfort PADK fittings is that you can use the modular system of activPilot Concept.

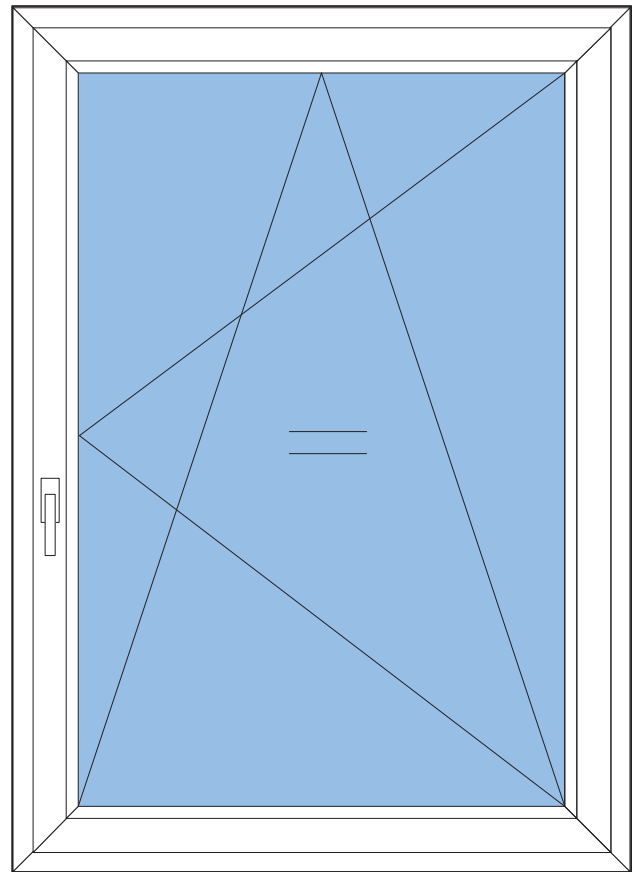

activPilot Comfort PADK

Application diagram for ascertaining the admissible sash sizes

- Max. sash weight 100 kg



For PVC-U windows with 12 mm airgap
PVC



Turn or turn-tilt sash with parallel opening

Width-to-height ratio and additional load

Value calculated without additional load for a width-to-height ratio of 1.5:1.

The application graphs have been calculated without additional loads. Please consult your authorised contact person for further information on how to calculate the maximum permissible window sash format with an additional load.

Advice for use

The application range permitted for using Winkhaus fitting is highlighted in grey in the application graphs. However, it is essential not to use the entire grey-highlighted section, but only those parts which are on the left-hand side of the curve for the respective GG filling weight.

Application range

The respective overall fitting must be selected from the original Winkhaus activPilot fitting components range. Winkhaus accepts no liability if non-original or unauthorised system accessory parts are used.

- Min. sash rebate width 460 mm
- Max. sash rebate width 1475 mm
- Min. sash rebate height 695 mm
- Max. sash rebate height 2300 mm
- Max. sash size 2.5 m²
- Max. sash weight 100 kg
- Aspect FFB/FFH ≤ 1.5:1
- Airgap 12 mm
- Groove centre position 13 mm
- Frame rebate depth min. 29 mm
- Approved for centre gasket systems and rebate sealing systems with rain guard.



Note: activPilot Comfort fittings are not suitable for use in panic doors! They are not recommended for passage doors.

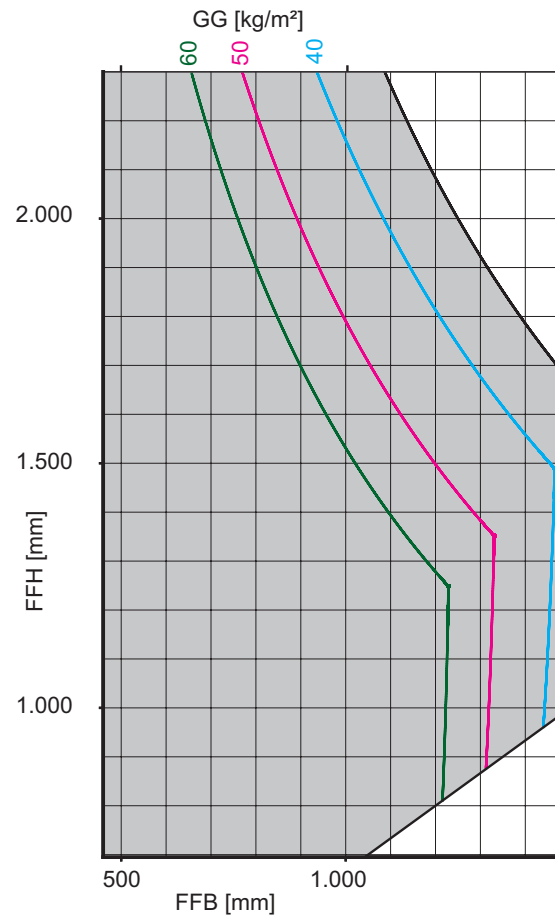

AWD_01.50_NR15_DK_100 kg_ohne_Zusatzlast_1,5_1475_m

Abbreviations

- FFB = Sash rebate width [mm]
- FFH = Sash rebate height [mm]
- GG = Glass weight per square metre [kg/m²]

Observe instructions on window profile

You must specifically take into account information provided by the profile manufacturer or system owner when determining the maximum sash sizes and sash weights!



Important: The screw connections of the load-bearing fitting components, such as corner, shear and sash hinges must be performed according to the TBDK guidelines. Adapt the drilling diameter for the fixing screws, the screw diameter and the screw length to the load situation.

System Testing RC2 (Resistance Class 2)

The RC2 processing details can be gathered from the RC2 system tests. The RC2 fitting lists in this catalogue are only application examples. Get in touch with your Winkhaus contact partner for more details.

Quick orientation

2

Our register system allows you to quickly allocate the listed component to the item in the fitting overview drawing. The item number specifies the chapter number in which the component can be found.

4.2
E2



4.2

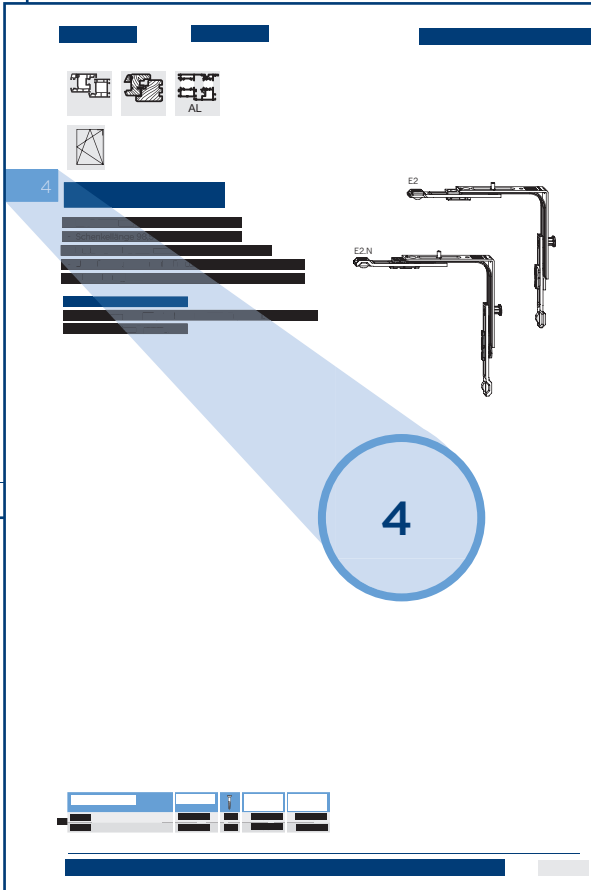

4

Lists of Fittings

| | |
|--|----|
| Turn fitting system – constant handle position Basic equipment activPilot Comfort PADK | 24 |
| Turn-tilt fitting system – central handle position Basic equipment activPilot Comfort PADK | 26 |
| Turn fitting system – constant handle position Suitable for burglary-resistant windows RC2 / RC2 N activPilot Comfort PADK | 28 |
| Turn-tilt fitting system – central handle position Suitable for burglary-resistant windows RC2 / RC2 N activPilot Comfort PADK | 30 |
| Turn double sash fitting system – constant handle position Basic equipment activPilot Comfort PADK | 32 |
| Turn double sash fitting system – central handle position Basic equipment activPilot Comfort PADK | 34 |

Turn-tilt fitting - constant handle position

Basic equipment
activPilot Comfort PADK

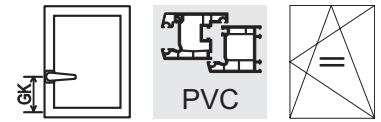

2

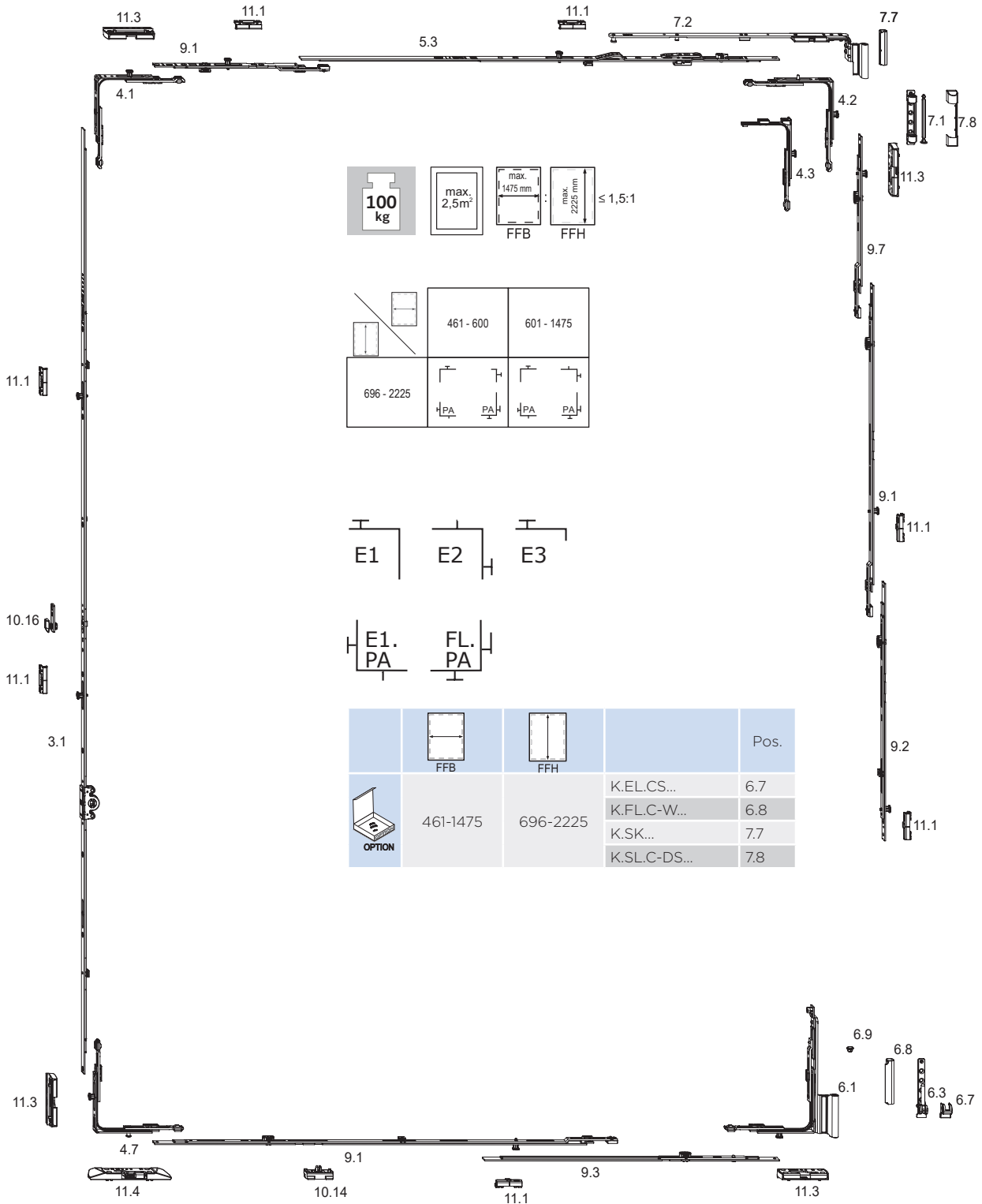







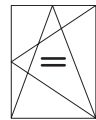
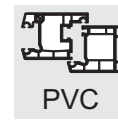
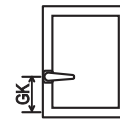



The shown distance between locking points is 800 mm.
The locking distances must be agreed with the system provider.

Turn-tilt fitting – constant handle position

Basic equipment



2

| |  |  | | Pos. | | Pos. | | Pos. | | Pos. | | | |
|---|---|---|---------------|-------------|----------|-------------|-------------|-----------|-----|--------------|----------|------|----|
|  | 461-1475 | | 696-850 | GAK.945-1 | 3.1 | FSF | 10.16 | GK = 260 | | SBA.K... | 11.1 | 1x | |
| | | | 851-1100 | GAK.1100-1 | 3.1 | FSF | 10.16 | GK = 375 | | SBA.K... | 11.1 | 1x | |
| | | | 1101-1325 | GAK.1325-1 | 3.1 | FSF | 10.16 | GK = 550 | | SBA.K... | 11.1 | 1x | |
| | | | 1326-1525 | GAK.1550-1 | 3.1 | FSF | 10.16 | GK = 550 | | SBA.K... | 11.1 | 1x | |
| | | | 1526-1775 | GAK.1775-2 | 3.1 | FSF | 10.16 | GK = 550 | | SBA.K... | 11.1 | 2x | |
| | | | 1776-2000 | GAK.2000-2 | 3.1 | FSF | 10.16 | GK = 1050 | | SBA.K... | 11.1 | 2x | |
| | | | 2001-2225 | GAK.2225-2 | 3.1 | FSF | 10.16 | GK = 1050 | | SBA.K... | 11.1 | 2x | |
|  | 461-1475 | 696-2225 | E1 | 4.1 | | | | | | SBS...PAB... | 11.3 | 1x | |
|  | 461-600 | 696-2225 | OS1.PA.600 | 5.3 | | | | | | | | | |
| | 601-775 | | OS2.PA.800 | 5.3 | | | | | | | | | |
| | 776-1025 | | OS2.PA.1025-1 | 5.3 | | | | | | | SBA.K... | 11.1 | 1x |
| | 1026-1275 | | OS2.PA.1025-1 | 5.3 | MK.250-1 | 9.1 | | | | | SBA.K... | 11.1 | 2x |
| | 1276-1475 | | OS2.PA.1025-1 | 5.3 | MK.500-1 | 9.1 | | | | | SBA.K... | 11.1 | 2x |
|  | 461-600 | 696-2225 | E3 | 4.3 | SL.C... | 7.1 | SC1.PA... | 7.3 | | | | | |
| | 601-1475 | | E2 | 4.2 | SL.C... | 7.1 | SC2.PA... | 7.2 | | | | | |
|  | 461-1475 | | 696-850 | MK.PA.250-1 | 9.7 | | | | | SBS...PAB... | 11.3 | 1x | |
| | | | 851-1075 | M.250-1 | 9.2 | MK.PA.250-1 | 9.7 | | | SBA.K... | 11.1 | 1x | |
| | | | 1076-1525 | M.500-1 | 9.2 | MK.PA.250-1 | 9.7 | | | SBA.K... | 11.1 | 1x | |
| | | | 1526-1800 | MK.500-1 | 9.1 | MK.PA.250-1 | 9.7 | M.500-1 | 9.2 | | SBA.K... | 11.1 | 2x |
| | | | 1801-2225 | MK.500-1 | 9.1 | MK.PA.250-1 | 9.7 | M.750-1 | 9.2 | | SBA.K... | 11.1 | 2x |
| | | | SBS...PAB... | 11.3 | | | | | | | | | |
|  | 461-1475 | 696-2225 | FL.C.PADK... | 6.1 | EL.CS... | 6.3 | S.FL.C-W... | 6.9 | | SBS...PAB... | 11.3 | 1x | |
|  | 461-710 | 696-2225 | KE SL | 9.3 | AL.M... | 10.14 | | | | | | | |
| | 711-960 | | KE SL | 9.3 | AL.M... | 10.14 | MK.250-1 | 9.1 | | SBA.K... | 11.1 | 1x | |
| | 961-1210 | | KE SL | 9.3 | AL.M... | 10.14 | MK.500-1 | 9.1 | | SBA.K... | 11.1 | 1x | |
| | 1211-1460 | | KE SL | 9.3 | AL.M... | 10.14 | MK.750-1 | 9.1 | | SBA.K... | 11.1 | 1x | |
| | 1461-1475 | | KE SL | 9.3 | AL.M... | 10.14 | MK.500-1 | 9.1 | | SBA.K... | 11.1 | 2x | |
| | | | MK.500-1 | 9.1 | | | | | | | | | |
|  | 461-1475 | 696-2225 | E1.PA | 4.7 | | | | | | SBS...PAB... | 11.3 | 1x | |
| | | | | | | | | | | SBK...PA... | 11.4 | 1x | |

Turn-tilt fitting - central handle position

Basic equipment
activPilot Comfort PADK

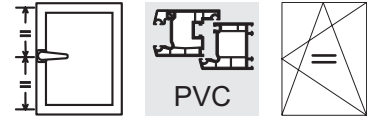

2

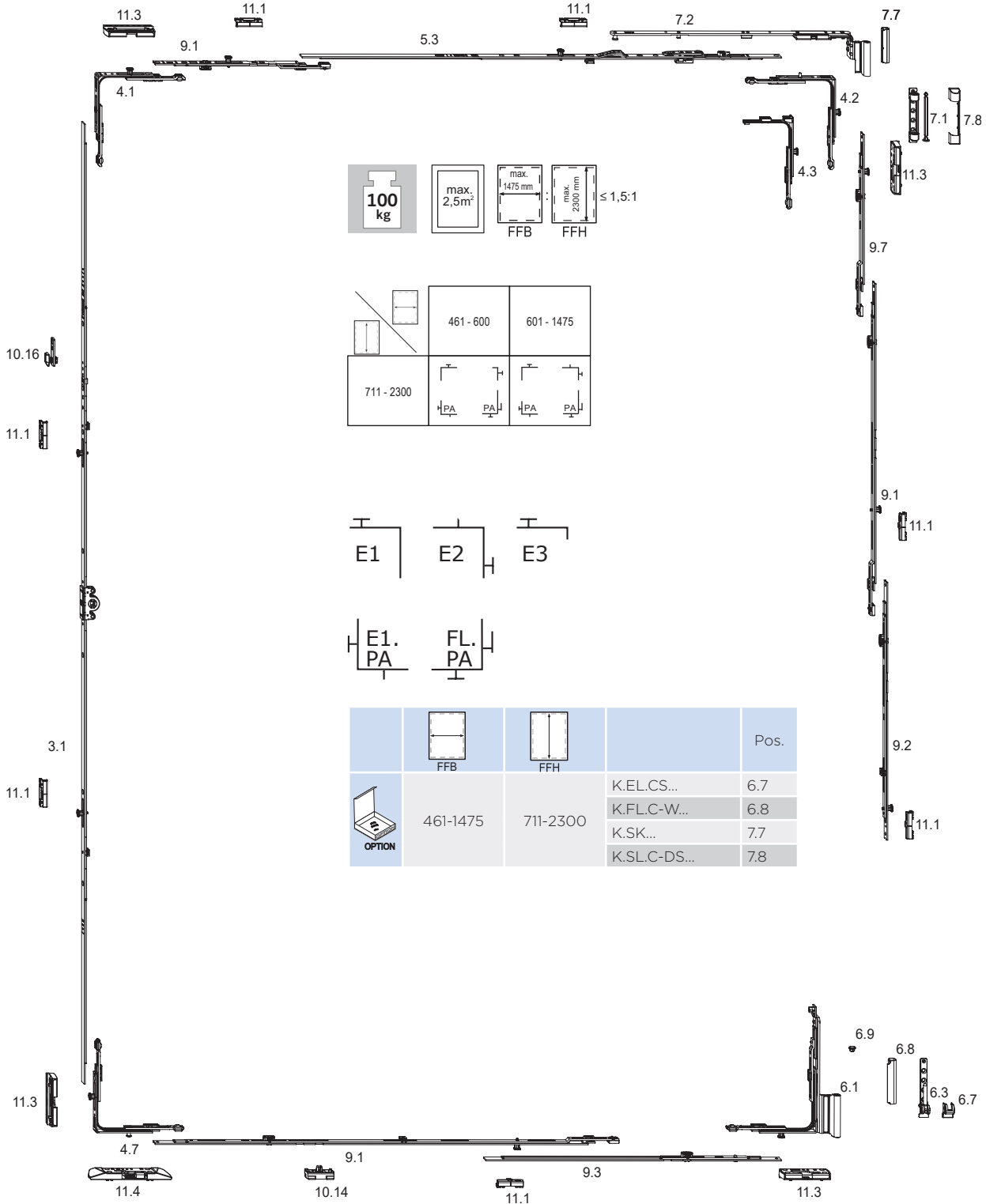







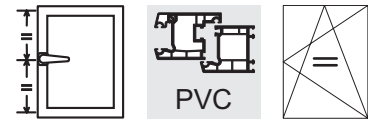



The shown distance between locking points is 800 mm.
The locking distances must be agreed with the system provider.

Turn-tilt fitting – central handle position

Basic equipment



| |  |  | | Pos. | | Pos. | | Pos. | | Pos. | |
|---|---|---|---------------|------|-------------|-------|-------------|------|--------------|------|----|
|  | 461-1475 | 711-980 | GAM.1050-1 | 3.1 | FSF | 10.16 | | | SBA.K... | 11.1 | 1x |
| | | 981-1400 | GAM.1400-1 | 3.1 | FSF | 10.16 | | | SBA.K... | 11.1 | 1x |
| | | 1401-1800 | GAM.1800-2 | 3.1 | FSF | 10.16 | | | SBA.K... | 11.1 | 2x |
| | | 1801-2300 | GAM.2300-3 | 3.1 | FSF | 10.16 | | | SBA.K... | 11.1 | 3x |
|  | 461-1475 | 711-2300 | E1 | 4.1 | | | | | SBS...PAB... | 11.3 | 1x |
|  | 461-600 | 711-2300 | OS1.PA.600 | 5.3 | | | | | | | |
| | 601-775 | | OS2.PA.800 | 5.3 | | | | | | | |
| | 776-1025 | | OS2.PA.1025-1 | 5.3 | | | | | SBA.K... | 11.1 | 1x |
| | 1026-1275 | | OS2.PA.1025-1 | 5.3 | MK.250-1 | 9.1 | | | SBA.K... | 11.1 | 2x |
| | 1276-1475 | | OS2.PA.1025-1 | 5.3 | MK.500-1 | 9.1 | | | SBA.K... | 11.1 | 2x |
|  | 461-600 | 711-2300 | E3 | 4.3 | SLC... | 7.1 | SC1.PA... | 7.3 | | | |
| | 601-1475 | | E2 | 4.2 | SLC... | 7.1 | SC2.PA... | 7.2 | | | |
|  | 461-1475 | 711-850 | MK.PA.250-1 | 9.7 | | | | | SBS...PAB... | 11.3 | 1x |
| | | 851-1075 | M.250-1 | 9.2 | MK.PA.250-1 | 9.7 | | | SBA.K... | 11.1 | 1x |
| | | 1076-1525 | M.500-1 | 9.2 | MK.PA.250-1 | 9.7 | | | SBS...PAB... | 11.3 | 1x |
| | | 1526-1800 | MK.500-1 | 9.1 | MK.PA.250-1 | 9.7 | M.500-1 | 9.2 | SBA.K... | 11.1 | 2x |
| | | 1801-2300 | MK.500-1 | 9.1 | MK.PA.250-1 | 9.7 | M.750-1 | 9.2 | SBS...PAB... | 11.3 | 1x |
|  | 461-1475 | 711-2300 | FL.C.PADK... | 6.1 | EL.CS... | 6.3 | S.FL.C-W... | 6.9 | SBS...PAB... | 11.3 | 1x |
|  | 461-710 | 711-2300 | KE SL | 9.3 | AL.M... | 10.14 | | | | | |
| | 711-960 | | KE SL | 9.3 | AL.M... | 10.14 | MK.250-1 | 9.1 | SBA.K... | 11.1 | 1x |
| | 961-1210 | | KE SL | 9.3 | AL.M... | 10.14 | MK.500-1 | 9.1 | SBA.K... | 11.1 | 1x |
| | 1211-1460 | | KE SL | 9.3 | AL.M... | 10.14 | MK.750-1 | 9.1 | SBA.K... | 11.1 | 1x |
| | 1461-1475 | | KE SL | 9.3 | AL.M... | 10.14 | MK.500-1 | 9.1 | SBA.K... | 11.1 | 2x |
| | | | MK.500-1 | 9.1 | | | | | | | |
|  | 461-1475 | 711-2300 | E1.PA | 4.7 | | | | | SBS...PAB... | 11.3 | 1x |
| | | | | | | | | | SBK...PA... | 11.4 | 1x |

Turn-tilt fitting – constant handle position

Suitable for burglary-resistant windows RC2 / RC2 N
activPilot Comfort PADK

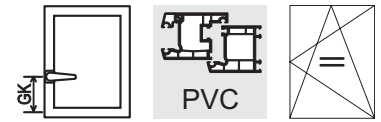

2

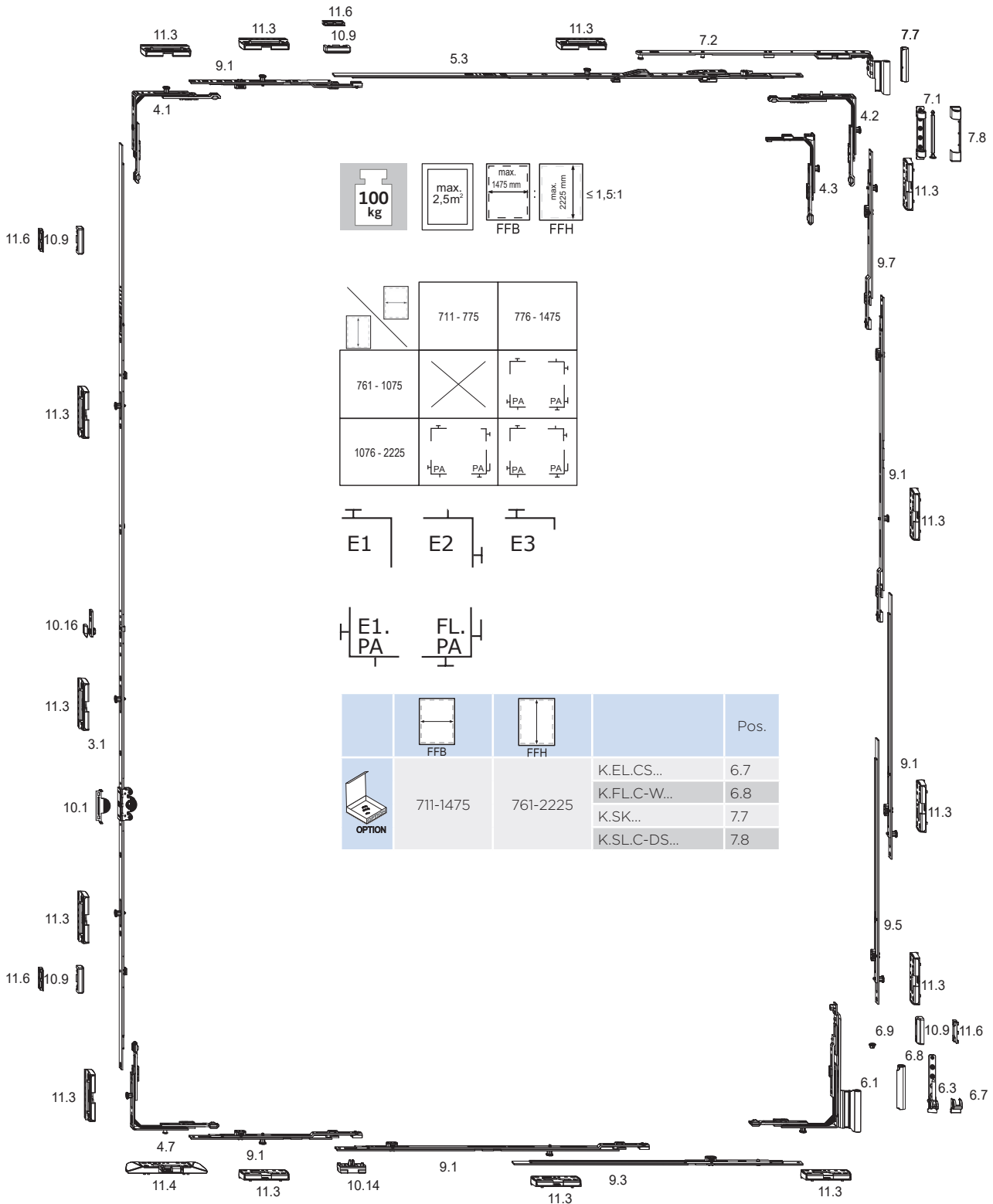







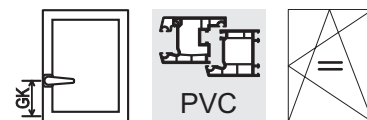



The shown distance between locking points is 800 mm.
The locking distances must be agreed with the system provider.

Turn-tilt fitting – constant handle position

Suitable for burglary-resistant windows RC2 / RC2 N



| |  |  | | Pos. | | Pos. | | Pos. | | Pos. | | |
|---|---|---|---------------|------------|-------------|----------|--------------|--------------|-----------------------------|--------------|----------|--|
|  | <i>i</i> 711-1475 | 761-2225 | AB.G.D.15,5 | 10.1 | AL D... | 10.9 | AL D... | 10.9 | FT WSK... | 11.6 | 2x | |
| | 776-1475 | 761-850 | GAK.945-1 | 3.1 | FSF | 10.16 | | | SBS...PAB... | 11.3 | 1x | |
| | | 851-1075 | GAK.1100-1 | 3.1 | FSF | 10.16 | | | SBS...PAB... | 11.3 | 1x | |
| | 711-1475 | 1076-1325 | GAK.1325-2 | 3.1 | FSF | 10.16 | | | SBS...PAB... | 11.3 | 2x | |
| | | 1326-1525 | GAK.1550-2 | 3.1 | FSF | 10.16 | | | SBS...PAB... | 11.3 | 2x | |
| | | 1526-1775 | GAK.1775-3 | 3.1 | FSF | 10.16 | | | SBS...PAB... | 11.3 | 3x | |
| | | 1776-2000 | GAK.2000-4 | 3.1 | FSF | 10.16 | | | SBS...PAB... | 11.3 | 4x | |
| | | 2001-2225 | GAK.2225-4 | 3.1 | FSF | 10.16 | | | SBS...PAB... | 11.3 | 4x | |
|  | <i>i</i> 711-1475 | 761-2225 | E1 | 4.1 | | | | | SBS...PAB... | 11.3 | 1x | |
|  | <i>i</i> 711-1475 | 761-2225 | AL D... | 10.9 | | | | | FT WSK... | 11.6 | 1x | |
| | 711-775 | 1076-2225 | OS1.PA.600 | 5.3 | MK.250-1 | 9.1 | | | SBS...PAB... | 11.3 | 1x | |
| | 776-1025 | | OS2.PA.1025-1 | 5.3 | | | | | SBS...PAB... | 11.3 | 1x | |
| | 1026-1275 | 761-2225 | OS2.PA.1025-1 | 5.3 | MK.250-1 | 9.1 | | | SBS...PAB... | 11.3 | 2x | |
| | 1276-1475 | | OS2.PA.1025-1 | 5.3 | MK.500-1 | 9.1 | | | SBS...PAB... | 11.3 | 2x | |
|  | 711-775 | 1076-2225 | E3 | 4.3 | SL.C... | 7.1 | SC1.PA... | 7.3 | | | | |
| | 776-1475 | 761-2225 | E2 | 4.2 | SL.C... | 7.1 | SC2.PA... | 7.2 | | | | |
|  | <i>i</i> 711-1475 | 761-2225 | AL D... | 10.9 | | | | | FT WSK... | 11.6 | 1x | |
| | 776-1475 | 761-1010 | MK.PA.250-1 | 9.7 | V.AK.450-1 | 9.5 | | | SBS...PAB... | 11.3 | 2x | |
| | | 1011-1075 | MK.250-1 | 9.1 | MK.PA.250-1 | 9.7 | V.AK.450-1 | 9.5 | SBS...PAB... | 11.3 | 3x | |
| | 711-1475 | 1076-1260 | MK.250-1 | 9.1 | MK.PA.250-1 | 9.7 | V.AK.450-1 | 9.5 | SBS...PAB... | 11.3 | 3x | |
| | | 1261-1510 | MK.500-1 | 9.1 | MK.PA.250-1 | 9.7 | V.AK.450-1 | 9.5 | SBS...PAB... | 11.3 | 3x | |
| | | 1511-1760 | MK.250-1 | 9.1 | MK.PA.250-1 | 9.7 | MK.500-1 | 9.1 | SBS...PAB... | 11.3 | 4x | |
| | | 1761-2010 | V.AK.450-1 | 9.5 | | | | | | | | |
| | | | MK.500-1 | 9.1 | MK.PA.250-1 | 9.7 | MK.500-1 | 9.1 | SBS...PAB... | 11.3 | 4x | |
| 2011-2225 | MK.250-1 | 9.1 | MK.PA.250-1 | 9.7 | MK.500-1 | 9.1 | SBS...PAB... | 11.3 | 5x | | | |
| | | MK.500-1 | 9.1 | V.AK.450-1 | 9.5 | | | | | | | |
|  | 776-1475 | 761-1075 | FL.C.PADK... | 6.1 | EL.CS... | 6.3 | S.FL.C-W... | 6.9 | SBS...PAB... | 11.3 | 1x | |
| | 711-1475 | 1076-2225 | FL.C.PADK... | 6.1 | EL.CS... | 6.3 | S.FL.C-W... | 6.9 | SBS...PAB... | 11.3 | 1x | |
|  | 711-960 | 1076-2225 | KE SL | 9.3 | AL.M... | 10.14 | MK.250-1 | 9.1 | SBS...PAB... | 11.3 | 1x | |
| | 776-960 | 761-1075 | KE SL | 9.3 | AL.M... | 10.14 | MK.250-1 | 9.1 | SBS...PAB... | 11.3 | 1x | |
| | 961-1210 | | KE SL | 9.3 | AL.M... | 10.14 | MK.250-1 | 9.1 | SBS...PAB... | 11.3 | 2x | |
| | | | MK.250-1 | 9.1 | | | | | | | | |
| | 1211-1460 | 761-2225 | KE SL | 9.3 | AL.M... | 10.14 | MK.250-1 | 9.1 | SBS...PAB... | 11.3 | 2x | |
| | | | MK.500-1 | 9.1 | | | | | | | | |
| 1461-1475 | | KE SL | 9.3 | AL.M... | 10.14 | MK.250-1 | 9.1 | SBS...PAB... | 11.3 | 3x | | |
| | | MK.250-1 | 9.1 | MK.500-1 | 9.1 | | | | | | | |
|  | <i>i</i> 711-1475 | 761-2225 | E1.PA | 4.7 | | | | | SBS...PAB... SBK...PA... | 11.3 11.4 | 1x 1x | |

i marks a line with items that are always used, regardless of size

Turn-tilt fitting – central handle position

Suitable for burglary-resistant windows RC2 / RC2 N
activPilot Comfort PADK

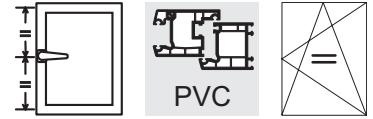

2

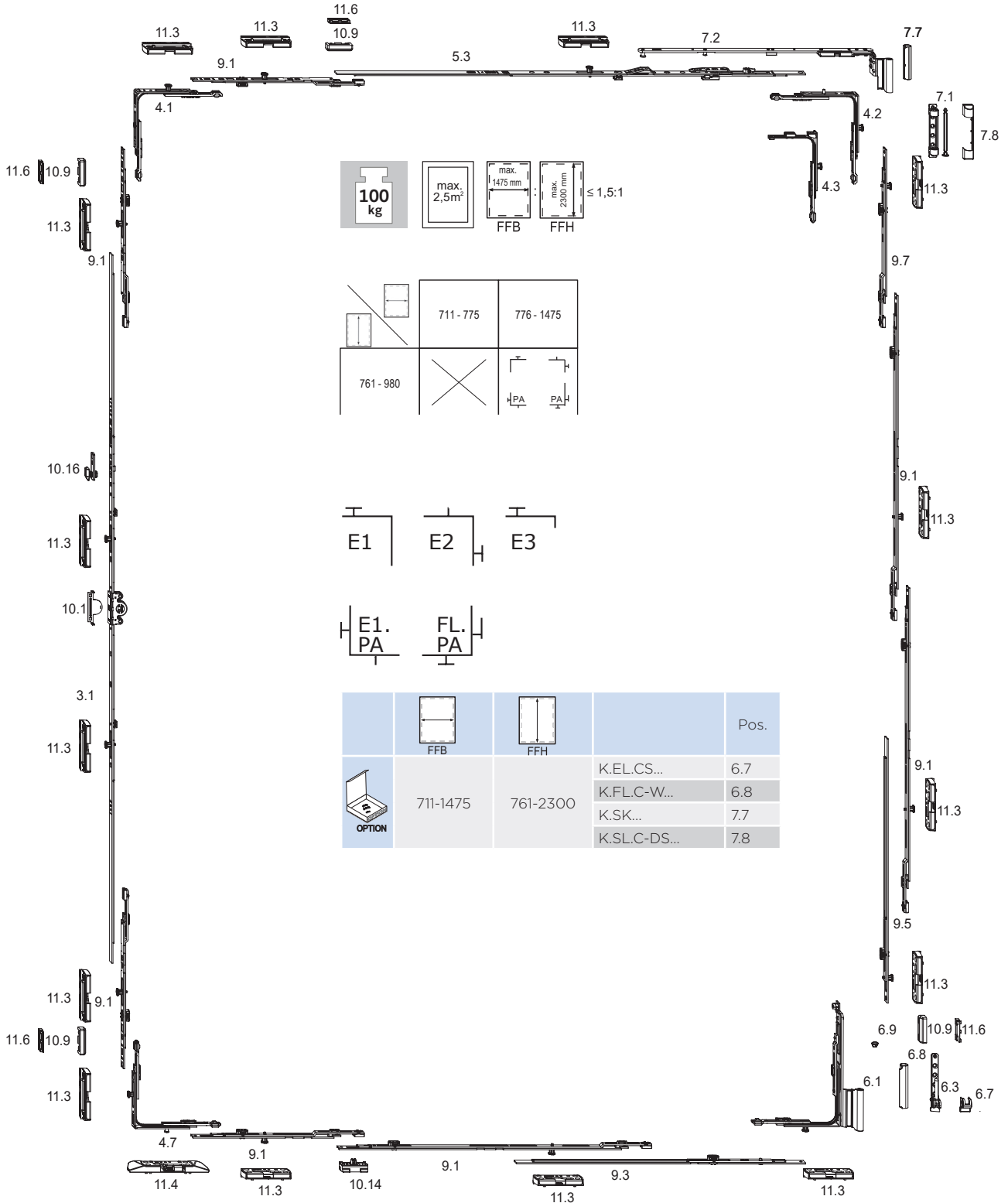







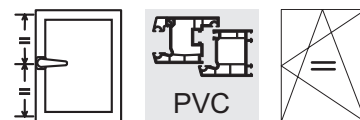









The shown distance between locking points is 800 mm.
The locking distances must be agreed with the system provider.

Turn-tilt fitting – central handle position

Suitable for burglary-resistant windows RC2 / RC2 N



| |  |  | | Pos. | | Pos. | | Pos. | | Pos. | |
|---|--|---|---------------|------------|-------------|-------------|--------------|--------------|--------------|--------------|------|
|  |  711-1475 | 761-2300 | AB.G.D.15,5 | 10.1 | AL D... | 10.9 | AL D... | 10.9 | FT WSK... | 11.6 | 2x |
| | 776-1475 | 761-980 | GAM.1050-1 | 3.1 | FSF | 10.16 | | | SBS...PAB... | 11.3 | 1x |
| | 711-1475 | 981-1300 | GAM.1400-2 | 3.1 | FSF | 10.16 | | | SBS...PAB... | 11.3 | 2x |
| | | 1301-1600 | GAM.1800-2 | 3.1 | FSF | 10.16 | | | SBS...PAB... | 11.3 | 2x |
| | 711-775 | 1601-1800 | GAM.1400-2 | 3.1 | FSF | 10.16 | MK.250-1 | 9.1 | SBS...PAB... | 11.3 | 4x |
| | 776-1475 | | MK.250-1 | 9.1 | GAM.1400-2 | 3.1 | FSF | 10.16 | | SBS...PAB... | 11.3 |
| | | 711-1475 | 1801-1900 | GAM.2300-3 | 3.1 | FSF | 10.16 | | | SBS...PAB... | 11.3 |
| | 711-775 | 1901-2300 | GAM.1400-2 | 3.1 | FSF | 10.16 | MK.500-1 | 9.1 | SBS...PAB... | 11.3 | 4x |
| 776-1475 | MK.500-1 | | 9.1 | GAM.1400-2 | 3.1 | FSF | 10.16 | | SBS...PAB... | 11.3 | 4x |
|  |  711-1475 | 761-2300 | E1 | 4.1 | | | | | SBS...PAB... | 11.3 | 1x |
|  |  711-1475 | 761-2300 | AL D... | 10.9 | | | | | FT WSK... | 11.6 | 1x |
| | 711-775 | 981-2300 | OS1.PA.600 | 5.3 | MK.250-1 | 9.1 | | | SBS...PAB... | 11.3 | 1x |
| | 776-1025 | 761-2300 | OS2.PA.1025-1 | 5.3 | | | | | SBS...PAB... | 11.3 | 1x |
| | 1026-1275 | | OS2.PA.1025-1 | 5.3 | MK.250-1 | 9.1 | | | SBS...PAB... | 11.3 | 2x |
| 1276-1475 | | OS2.PA.1025-1 | 5.3 | MK.500-1 | 9.1 | | | SBS...PAB... | 11.3 | 2x | |
|  | 711-775 | 981-2300 | E3 | 4.3 | SL.C... | 7.1 | SC1.PA... | 7.3 | | | |
| | 776-1475 | 761-2300 | E2 | 4.2 | SL.C... | 7.1 | SC2.PA... | 7.2 | | | |
|  |  711-1475 | 761-2300 | AL D... | 10.9 | | | | | FT WSK... | 11.6 | 1x |
| | 776-1475 | 761-980 | MK.PA.250-1 | 9.7 | V.AK.450-1 | 9.5 | | | SBS...PAB... | 11.3 | 2x |
| | 711-1475 | 981-1010 | MK.PA.250-1 | 9.7 | V.AK.450-1 | 9.5 | | | SBS...PAB... | 11.3 | 2x |
| | | 1011-1260 | MK.250-1 | 9.1 | MK.PA.250-1 | 9.7 | V.AK.450-1 | 9.5 | SBS...PAB... | 11.3 | 3x |
| | | 1261-1510 | MK.500-1 | 9.1 | MK.PA.250-1 | 9.7 | V.AK.450-1 | 9.5 | SBS...PAB... | 11.3 | 3x |
| | | 1511-1760 | MK.250-1 | 9.1 | MK.PA.250-1 | 9.7 | MK.500-1 | 9.1 | SBS...PAB... | 11.3 | 4x |
| | | | V.AK.450-1 | 9.5 | | | | | | | |
| | | 1761-2010 | MK.500-1 | 9.1 | MK.PA.250-1 | 9.7 | MK.500-1 | 9.1 | SBS...PAB... | 11.3 | 4x |
| 2011-2260 | V.AK.450-1 | 9.5 | | | | | | | | | |
| | MK.250-1 | 9.1 | MK.PA.250-1 | 9.7 | MK.500-1 | 9.1 | SBS...PAB... | 11.3 | 5x | | |
| 2261-2300 | MK.500-1 | 9.1 | MK.PA.250-1 | 9.7 | MK.500-1 | 9.1 | SBS...PAB... | 11.3 | 5x | | |
| 776-1475 | 761-980 | FL.C.PADK... | 6.1 | EL.CS... | 6.3 | S.FL.C-W... | 6.9 | SBS...PAB... | 11.3 | 1x | |
|  | 711-1475 | 981-2300 | FL.C.PADK... | 6.1 | EL.CS... | 6.3 | S.FL.C-W... | 6.9 | SBS...PAB... | 11.3 | 1x |
|  | 711-960 | 981-2300 | KE SL | 9.3 | AL.M... | 10.14 | MK.250-1 | 9.1 | SBS...PAB... | 11.3 | 1x |
| | 776-960 | 761-980 | KE SL | 9.3 | AL.M... | 10.14 | MK.250-1 | 9.1 | SBS...PAB... | 11.3 | 1x |
| | 961-1210 | 761-2300 | KE SL | 9.3 | AL.M... | 10.14 | MK.250-1 | 9.1 | SBS...PAB... | 11.3 | 2x |
| | | | MK.250-1 | 9.1 | | | | | | | |
| | 1211-1460 | 761-2300 | KE SL | 9.3 | AL.M... | 10.14 | MK.250-1 | 9.1 | SBS...PAB... | 11.3 | 2x |
| 1461-1475 | 761-2300 | MK.500-1 | 9.1 | | | | | | | | |
| | | KE SL | 9.3 | AL.M... | 10.14 | MK.250-1 | 9.1 | SBS...PAB... | 11.3 | 3x | |
| 1461-1475 | 761-2300 | KE SL | 9.3 | AL.M... | 10.14 | MK.250-1 | 9.1 | SBS...PAB... | 11.3 | 3x | |
| 1461-1475 | 761-2300 | MK.250-1 | 9.1 | MK.500-1 | 9.1 | | | | | | |
|  |  711-1475 | 761-2300 | E1.PA | 4.7 | | | | | SBK...PA... | 11.4 | 1x |
| | | | | | | | | | SBS...PAB... | 11.3 | 1x |

 marks a line with items that are always used, regardless of size

2

Turn double sash fitting - constant handle position

Basic equipment
activPilot Comfort PADK

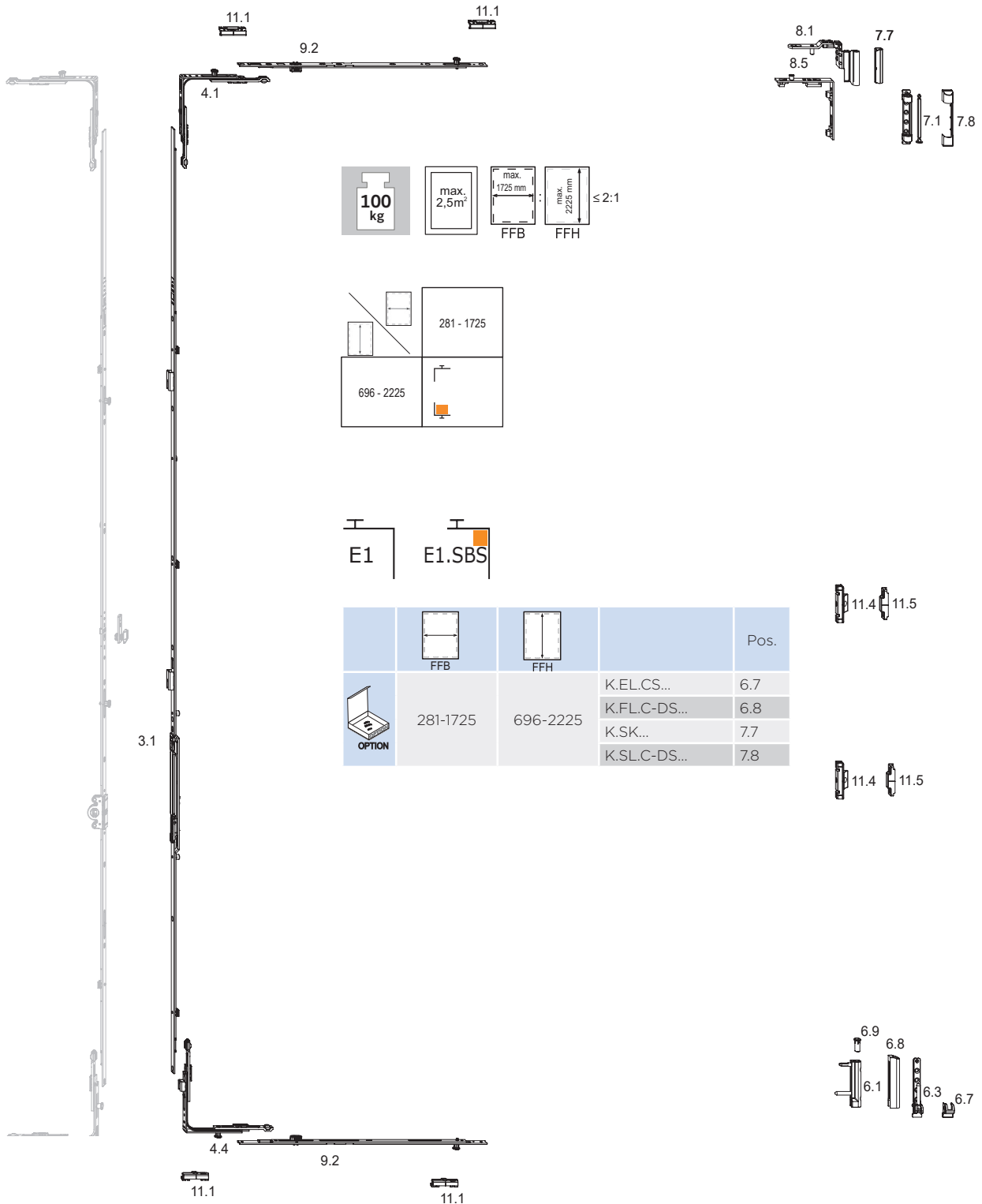
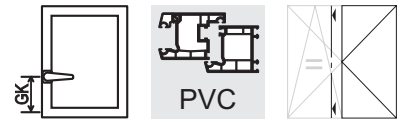

100 kg
max. 2,5m²
max. 1725 mm FFB
max. 2225 mm FFH
≤ 2:1

281 - 1725
696 - 2225

E1 E1.SBS







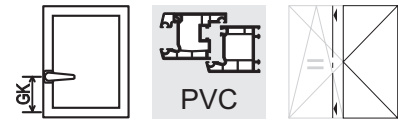



| | FFB | FFH | | Pos. |
|--|----------|----------|--------------|------|
| | | | K.EL.CS... | 6.7 |
| | | | K.FL.C-DS... | 6.8 |
|  OPTION | 281-1725 | 696-2225 | K.SK... | 7.7 |
| | | | K.SL.C-DS... | 7.8 |

The shown distance between locking points is 800 mm.
The locking distances must be agreed with the system provider.

Turn double sash fitting - constant handle position



Basic equipment

| |  |  | | Pos. | | Pos. | | Pos. | | Pos. | | |
|---|---|---|------------|-------------|--------------|------|----------|-----------|----------|------|----|--|
|  | 281-1400 | 696-700 | GASK.710 | 3.1 | | | GK = 210 | | | | | |
| | 281-1700 | 701-850 | GASK.945-1 | 3.1 | | | GK = 260 | | | | | |
| | 281-1725 | 851-1100 | | GASK.1100-1 | 3.1 | | | GK = 375 | | | | |
| | | 1101-1325 | | GASK.1325-1 | 3.1 | | | GK = 550 | | | | |
| | | 1326-1550 | | GASK.1550-1 | 3.1 | | | GK = 550 | | | | |
| | | 1551-1775 | | GASK.1775-2 | 3.1 | | | GK = 550 | | | | |
| | | 1776-2000 | | GASK.2000-2 | 3.1 | | | GK = 1050 | | | | |
| | | 2001-2225 | | GASK.2225-2 | 3.1 | | | GK = 1050 | | | | |
|  | 281-1725 | 696-2225 | E1 | 4.1 | | | | | SBA.K... | 11.1 | 1x | |
|  | 841-1250 | | M.500-1 | 9.2 | | | | | SBA.K... | 11.1 | 1x | |
| | 1251-1500 | 696-2225 | M.750-1 | 9.2 | | | | | SBA.K... | 11.1 | 1x | |
| | 1501-1725 | | MK.500-1 | 9.1 | M.500-1 | 9.2 | | | SBA.K... | 11.1 | 2x | |
|  | 281-1725 | 696-2225 | DLW ERW SL | 8.5 | DLC.20-13.RS | 8.1 | SLC... | 7.1 | | | | |
|  | 281-1725 | 801-1600 | ZV-FT SL | 11.4 | | | | | ZV-RT... | 11.5 | 1x | |
| | | 1601-2225 | ZV-FT SL | 11.4 | ZV-FT SL | 11.4 | | | ZV-RT... | 11.5 | 2x | |
|  | 281-1725 | 696-2225 | S.FL.C... | 6.9 | | | | | | | | |
| | | | EL.CS... | 6.3 | FL.C... | 6.1 | | | | | | |
|  | 841-1250 | | M.500-1 | 9.2 | | | | | SBA.K... | 11.1 | 1x | |
| | 1251-1500 | 696-2225 | M.750-1 | 9.2 | | | | | SBA.K... | 11.1 | 1x | |
| | 1501-1725 | | MK.500-1 | 9.1 | M.500-1 | 9.2 | | | SBA.K... | 11.1 | 2x | |
|  | 281-1725 | 696-2225 | E1.SBS.U.F | 4.4 | | | | | SBA.K... | 11.1 | 1x | |

Turn double-sash fitting - central handle position

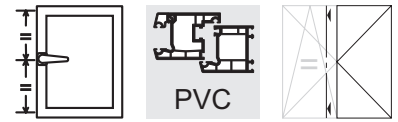

2

Basic equipment
activPilot Comfort PADK

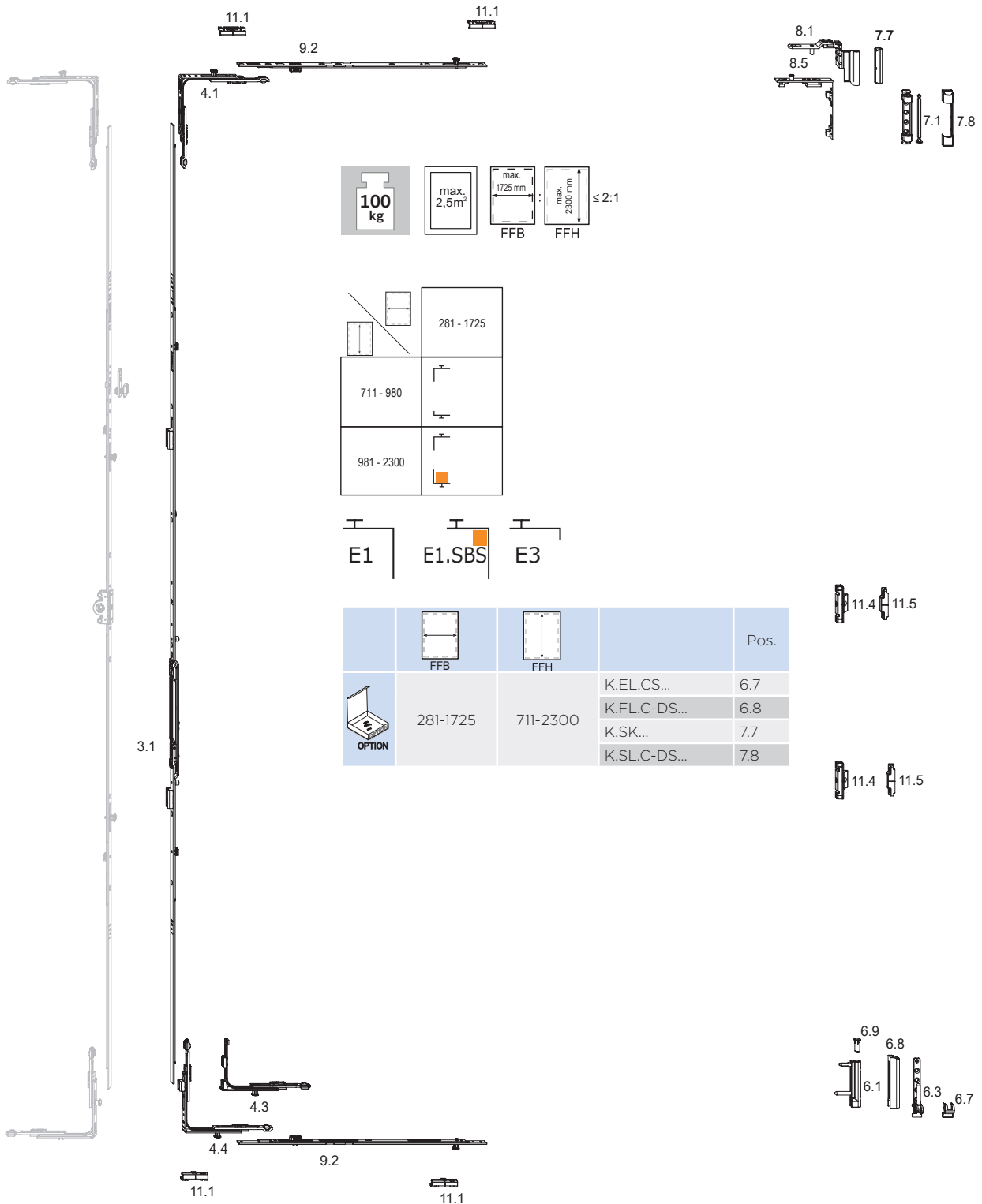

The shown distance between locking points is 800 mm.
The locking distances must be agreed with the system provider.

Turn double-sash fitting - central handle position

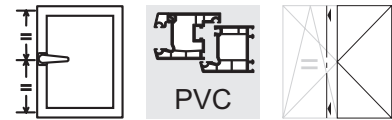

Basic equipment

| |  |  | | Pos. | | Pos. | | Pos. | | Pos. | |
|---|---|---|----------------|------|---------------|------|---------|------|----------|------|----|
|  | 281-1725 | 711-980 | GASM.1050-1.E3 | 3.1 | | | | | | | |
| | | 981-1400 | GASM.1400-1 | 3.1 | | | | | | | |
| | | 1401-1800 | GASM.1800-2 | 3.1 | | | | | | | |
| | | 1801-2300 | GASM.2300-3 | 3.1 | | | | | | | |
|  | 281-1725 | 711-2300 | E1 | 4.1 | | | | | SBA.K... | 11.1 | 1x |
|  | 841-1250 | 711-2300 | M.500-1 | 9.2 | | | | | SBA.K... | 11.1 | 1x |
| | 1251-1500 | | M.750-1 | 9.2 | | | | | SBA.K... | 11.1 | 1x |
| | 1501-1725 | | MK.500-1 | 9.1 | M.500-1 | 9.2 | | | SBA.K... | 11.1 | 2x |
|  | 281-1725 | 711-2300 | DLW ERW SL | 8.5 | DL.C.20-13.RS | 8.1 | SL.C... | 7.1 | | | |
|  | 281-1725 | 801-1600 | ZV-FT SL | 11.4 | | | | | ZV-RT... | 11.5 | 1x |
| | | 1601-2300 | ZV-FT SL | 11.4 | ZV-FT SL | 11.4 | | | ZV-RT... | 11.5 | 2x |
|  | 281-1725 | 711-2300 | S.FL.C... | 6.9 | | | | | | | |
| | | | EL.CS... | 6.3 | FL.C... | 6.1 | | | | | |
|  | 841-1250 | 711-2300 | M.500-1 | 9.2 | | | | | SBA.K... | 11.1 | 1x |
| | 1251-1500 | | M.750-1 | 9.2 | | | | | SBA.K... | 11.1 | 1x |
| | 1501-1725 | | MK.500-1 | 9.1 | M.500-1 | 9.2 | | | SBA.K... | 11.1 | 2x |
|  | 281-1725 | 711-980 | E3 | 4.3 | | | | | SBA.K... | 11.1 | 1x |
| | | 981-2300 | E1.SBS.U.F | 4.4 | | | | | SBA.K... | 11.1 | 1x |

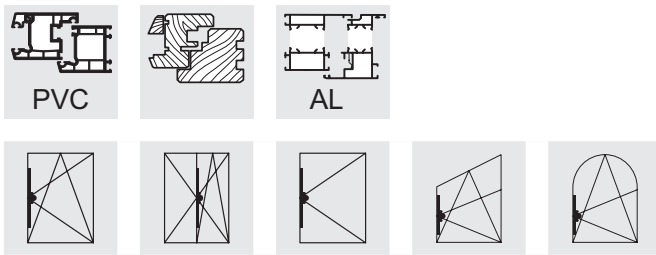

3

Drive rod GAK

- Constant handle position GK
- Backset 15.5 mm
- Clampable in fitting groove
- Functional parts such as DFE and TFE retrofittable (see table), does not apply to activPilot Comfort
- Handle position with reference to the sash rebate edge, in conformity with "dimension GK" (see table)
- For drilling and milling instructions see Group 15 installation drawings B-3-1
- Gear case for milling from rebate
- Gear case for mounting in drilled hole
- Fasten the window handle attachment with M5 x ..., DIN 965, 43 mm screw centres

drive rod GAK... BK

- With pre-assembled balcony door catch bolt
- Not suitable for activPilot Comfort / duoPort PAS

drive rod GAK... C

- incl. reinforced clamping mechanism within the profile groove



| Item designation | Item no. | Application range |  | Dimension GK | DFE | TFE | VPA1 Pcs/type | VPA2 Pcs/type | VPA3 Pcs/type |
|------------------|----------|-------------------|---|--------------|-----|-----|---------------|---------------|---------------|
| GAK.465 | 4926221 | FFH 420 - 520 | 0 | 210 | | | 10 BD | 100 KK | 800 EK |
| GAK.465.C | 4935841 | FFH 420 - 520 | 0 | 210 | | | 10 BD | 100 KK | 800 EK |
| GAK.710 | 4926207 | FFH 460 - 710 | 1 | 210 | | | 20 BD | 600 EA | |
| GAK.710.C | 4935843 | FFH 460 - 710 | 1 | 210 | | | 20 BD | 600 EA | |
| GAK.830 | 4926230 | FFH 580 - 830 | 2 | 260 | | | 20 BD | 600 EA | |
| GAK.830-1 | 4926231 | FFH 580 - 830 | 2 | 260 | | | 20 BD | 600 EA | |
| GAK.945 | 4926208 | FFH 695 - 945 | 3 | 260 | • | • | 20 BD | 400 EA | |
| GAK.945-1 | 4926209 | FFH 695 - 945 | 3 | 260 | • | • | 20 BD | 400 EA | |
| GAK.1100-1 | 4926234 | FFH 850 - 1100 | 3 | 375 | • | • | 20 BD | 360 EA | |
| GAK.1195-1 | 4926236 | FFH 945 - 1195 | 4 | 470 | • | • | 20 BD | 360 EA | |
| GAK.1195-2 | 4926237 | FFH 945 - 1195 | 4 | 470 | • | • | 20 BD | 360 EA | |
| GAK.1325-1 | 4978659 | FFH 1075 - 1325 | 4 | 550 | • | • | 20 BD | 360 EA | |
| GAK.1325-1.G500 | 4937485 | FFH 1075 - 1325 | 5 | 500 | • | • | 20 BD | 360 EA | |
| GAK.1325-2 | 4978670 | FFH 1075 - 1325 | 4 | 550 | • | • | 20 BD | 360 EA | |
| GAK.1550-1 | 4926224 | FFH 1300 - 1550 | 5 | 550 | • | • | 10 BD | 360 L1 | |
| GAK.1550-2 | 4926225 | FFH 1300 - 1550 | 5 | 550 | • | • | 10 BD | 360 L1 | |
| GAK.1775-2 | 4926228 | FFH 1525 - 1775 | 7 | 550 | • | • | 10 BD | 400 L1 | |
| GAK.1775-3 | 4926229 | FFH 1525 - 1775 | 7 | 550 | • | • | 10 BD | 400 L1 | |
| GAK.1850-2 | 5000529 | FFH 1600 - 1850 | 7 | 715 | • | • | 10 BD | 360 L1 | |
| GAK.2000-2 | 4938089 | FFH 1750 - 2000 | 8 | 1050 | • | • | 10 BD | 360 L2 | |
| GAK.2000-2.BK | 4942670 | FFH 1750 - 2000 | 8 | 1050 | • | • | 10 BD | 360 L2 | |
| GAK.2000-4 | 4938120 | FFH 1750 - 2000 | 8 | 1050 | • | • | 10 BD | 360 L2 | 800 EU2 |
| GAK.2225-2 | 4938122 | FFH 1975 - 2225 | 9 | 1050 | • | • | 10 BD | 360 L2 | |
| GAK.2225-2.BK | 4942672 | FFH 1975 - 2225 | 9 | 1050 | • | • | 10 BD | 360 L2 | |
| GAK.2225-4 | 4938123 | FFH 1975 - 2225 | 9 | 1050 | • | • | 10 BD | 360 L2 | 800 EU2 |
| GAK.2225-4.BK | 4942673 | FFH 1975 - 2225 | 9 | 1050 | • | • | 10 BD | 360 L2 | |
| GAK.2450-4 | 5021551 | FFH 2200 - 2450 | 10 | 1050 | • | • | 10 BD | 360 L2 | |

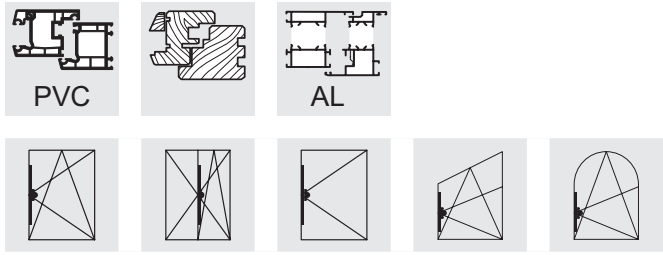



Drive rod GAK V < 700

- Constant handle position GK
- Backset 15.5 mm
- Locking gap less than 700 mm (V < 700)
- Clampable in fitting groove
- Functional parts such as DFE and TFE retrofittable (see table), does not apply to activPilot Comfort
- Handle position with reference to the sash rebate edge, in conformity with "dimension GK" (see table)
- For drilling and milling instructions see Group 15 installation drawings B-3-1
- Gear case for milling from rebate
- Gear case for mounting in drilled hole
- Fasten the window handle attachment with M5 x ..., DIN 965, 43 mm screw centres

drive rod GAK... BK

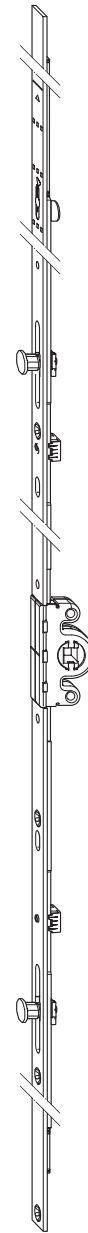
- With pre-assembled balcony door catch bolt
- Not suitable for activPilot Comfort / duoPort PAS



| Item designation | Item no. | Application range |  | Dimension GK | DFE | TFE | VPA1 Pcs/type | VPA2 Pcs/type | VPA3 Pcs/type |
|------------------|----------|-------------------|---|--------------|-----|-----|---------------|---------------|---------------|
| GAK.830-1 | 4926231 | FFH 580 - 830 | 2 | 260 | | | 20 BD | 600 EA | |
| GAK.945-1 | 4926209 | FFH 695 - 945 | 3 | 260 | • | • | 20 BD | 400 EA | |
| GAK.1100-1 | 4926234 | FFH 850 - 1100 | 3 | 375 | • | • | 20 BD | 360 EA | |
| GAK.1195-2 | 4926237 | FFH 945 - 1195 | 4 | 470 | • | • | 20 BD | 360 EA | |
| GAK.1325-2 | 4978670 | FFH 1075 - 1325 | 4 | 550 | • | • | 20 BD | 360 EA | |
| GAK.1550-2 | 4926225 | FFH 1300 - 1550 | 5 | 550 | • | • | 10 BD | 360 L1 | |
| GAK.1775-3 | 4926229 | FFH 1525 - 1775 | 7 | 550 | • | • | 10 BD | 400 L1 | |
| GAK.2000-4 | 4938120 | FFH 1750 - 2000 | 8 | 1050 | • | • | 10 BD | 360 L2 | 800 EU2 |
| GAK.2225-4 | 4938123 | FFH 1975 - 2225 | 9 | 1050 | • | • | 10 BD | 360 L2 | 800 EU2 |
| GAK.2225-4.BK | 4942673 | FFH 1975 - 2225 | 9 | 1050 | • | • | 10 BD | 360 L2 | |
| GAK.2450-4 | 5021551 | FFH 2200 - 2450 | 10 | 1050 | • | • | 10 BD | 360 L2 | |

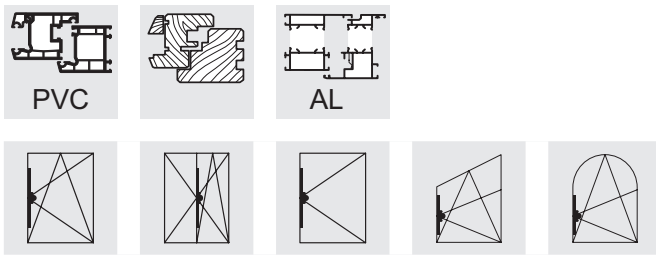

3

Drive rod GAK ... D 7.5

- Constant handle position GK
- Backset 7.5 mm
- Clampable in fitting groove
- Functional parts such as DFE and TFE retrofittable (see table), does not apply to activPilot Comfort
- Handle position with reference to the sash rebate edge, in conformity with "dimension GK" (see table)
- For drilling and milling instructions see Group 15 installation drawings B-3-2
- Gear case for milling from rebate
- Gear case for mounting in drilled hole
- Fasten the window handle attachment with M5 x ..., DIN 965, 43 mm screw centres



| Item designation | Item no. | Application range |  | Dimension GK | DFE | TFE | VPA1 Pcs/type | VPA2 Pcs/type | VPA3 Pcs/type |
|------------------|----------|-------------------|---|--------------|-----|-----|---------------|---------------|---------------|
| GAK.700.D7,5 | 4983049 | FFH 530 - 700 | 2 | 260 | | | 20 BD | 400 EA | |
| GAK.830-1.D7,5 | 4969431 | FFH 580 - 830 | 2 | 260 | | | 20 BD | 400 EA | |
| GAK.945-0.D7,5 | 5027123 | FFH 695 - 945 | 3 | 260 | • | • | 20 BD | 400 EA | |
| GAK.945-1.D7,5 | 4969430 | FFH 695 - 945 | 3 | 260 | • | • | 20 BD | 400 EA | |
| GAK.1100-1.D7,5 | 4969429 | FFH 850 - 1100 | 3 | 375 | • | • | 20 BD | 360 EA | |
| GAK.1195-1.D7,5 | 4969428 | FFH 945 - 1195 | 4 | 470 | • | • | 20 BD | 360 EA | |
| GAK.1195-2.D7,5 | 4980490 | FFH 945 - 1195 | 4 | 470 | • | • | 20 BD | 360 EA | |
| GAK.1325-1.D7,5 | 4969427 | FFH 1075 - 1325 | 4 | 550 | • | • | 20 BD | 360 EA | |
| GAK.1325-2.D7,5 | 4969426 | FFH 1075 - 1325 | 4 | 550 | • | • | 20 BD | 360 EA | |
| GAK.1550-1.D7,5 | 4969425 | FFH 1300 - 1550 | 5 | 550 | • | • | 10 BD | 400 L1 | |
| GAK.1550-2.D7,5 | 4969424 | FFH 1300 - 1550 | 5 | 550 | • | • | 10 BD | 400 L1 | |
| GAK.1775-2.D7,5 | 4969423 | FFH 1525 - 1775 | 7 | 550 | • | • | 10 BD | 400 L1 | |
| GAK.1775-3.D7,5 | 4969422 | FFH 1525 - 1775 | 7 | 550 | • | • | 10 BD | 400 L1 | |
| GAK.1850-2.D7,5 | 4969416 | FFH 1600 - 1850 | 7 | 715 | • | • | 10 BD | 360 L1 | |
| GAK.2000-2.D7,5 | 4969415 | FFH 1750 - 2000 | 8 | 1050 | • | • | 10 BD | 360 L2 | 900 EU2 |
| GAK.2000-4.D7,5 | 4969412 | FFH 1750 - 2000 | 8 | 1050 | • | • | 10 BD | 360 L2 | 800 EU2 |
| GAK.2225-2.D7,5 | 4969410 | FFH 1975 - 2225 | 9 | 1050 | • | • | 10 BD | 360 L2 | 900 EU2 |
| GAK.2225-4.D7,5 | 4969407 | FFH 1975 - 2225 | 9 | 1050 | • | • | 10 BD | 360 L2 | 800 EU2 |

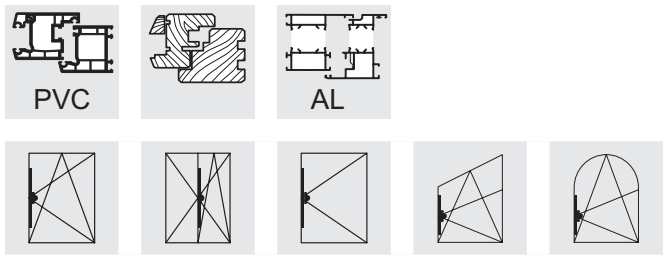

Drive rod GAK ... D 7.5 V < 700

- Constant handle position GK
- Locking gap less than 700 mm (V < 700)
- Backset 7.5 mm
- Clampable in fitting groove
- Functional parts such as DFE and TFE retrofittable (see table), does not apply to activPilot Comfort
- Handle position with reference to the sash rebate edge, in conformity with "dimension GK" (see table)
- For drilling and milling instructions see Group 15 installation drawings B-3-2
- Gear case for milling from rebate
- Gear case for mounting in drilled hole
- Fasten the window handle attachment with M5 x ..., DIN 965, 43 mm screw centres



| Item designation | Item no. | Application range |  | Dimension GK | DFE | TFE | VPA1 Pcs/type | VPA2 Pcs/type | VPA3 Pcs/type |
|------------------|----------|-------------------|---|--------------|-----|-----|---------------|---------------|---------------|
| GAK.830-1.D7,5 | 4969431 | FFH 580 - 830 | 2 | 260 | | | 20 BD | 400 EA | |
| GAK.945-1.D7,5 | 4969430 | FFH 695 - 945 | 3 | 260 | • | • | 20 BD | 400 EA | |
| GAK.1100-1.D7,5 | 4969429 | FFH 850 - 1100 | 3 | 375 | • | • | 20 BD | 360 EA | |
| GAK.1195-2.D7,5 | 4980490 | FFH 945 - 1195 | 4 | 470 | • | • | 20 BD | 360 EA | |
| GAK.1325-2.D7,5 | 4969426 | FFH 1075 - 1325 | 4 | 550 | • | • | 20 BD | 360 EA | |
| GAK.1550-2.D7,5 | 4969424 | FFH 1300 - 1550 | 5 | 550 | • | • | 10 BD | 400 L1 | |
| GAK.1775-3.D7,5 | 4969422 | FFH 1525 - 1775 | 7 | 550 | • | • | 10 BD | 400 L1 | |
| GAK.2000-4.D7,5 | 4969412 | FFH 1750 - 2000 | 8 | 1050 | • | • | 10 BD | 360 L2 | 800 EU2 |
| GAK.2225-4.D7,5 | 4969407 | FFH 1975 - 2225 | 9 | 1050 | • | • | 10 BD | 360 L2 | 800 EU2 |

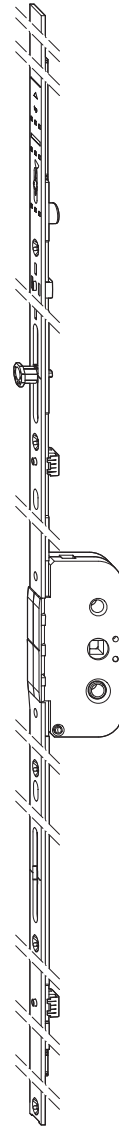
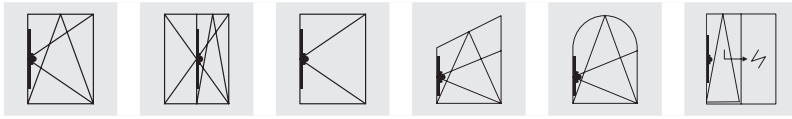

3

Drive rod GAK ... D 25 - 50

- Constant handle position GK
- The backset is optionally 25, 30, 35, 40, 45 or 50 mm
- Clampable in fitting groove
- Functional parts such as DFE and TFE retrofittable (see table), does not apply to activPilot Comfort
- Extensible with extension rods
- Handle position with reference to the sash rebate edge, in conformity with "dimension GK" (see table)
- For drilling and milling instructions see group 15, installation drawings B-3-4
- Gear case for milling from rebate
- Fasten the window handle attachment with M5 x ..., DIN 965, 43 mm screw centres

| Item designation | Item no. | Application range |  | Dimension GK | DFE | TFE | VPA1 Pcs/type | VPA2 Pcs/type | VPA3 Pcs/type |
|------------------|----------|-------------------|---|--------------|-----|-----|---------------|---------------|---------------|
| GAK.1325-1.D25 | 4978671 | FFH 1075 - 1325 | 4 | 550 | • | • | 10 BD | 200 EA | |
| GAK.1325-1.D30 | 4978672 | FFH 1075 - 1325 | 4 | 550 | • | • | 10 BD | 200 EA | |
| GAK.1325-1.D35 | 4978673 | FFH 1075 - 1325 | 4 | 550 | • | • | 10 BD | 200 EA | |
| GAK.1325-1.D40 | 4978674 | FFH 1075 - 1325 | 4 | 550 | • | • | 10 BD | 200 EA | |
| GAK.1325-1.D45 | 4978675 | FFH 1075 - 1325 | 4 | 550 | • | • | 10 BD | 200 EA | |
| GAK.1325-1.D50 | 4978676 | FFH 1075 - 1325 | 4 | 550 | • | • | 10 BD | 200 EA | |
| GAK.2000-4.D25 | 4938143 | FFH 1750 - 2000 | 8 | 1050 | • | • | 10 BD | 200 L2 | 400 EU2 |
| GAK.2000-4.D30 | 4938150 | FFH 1750 - 2000 | 8 | 1050 | • | • | 10 BD | 200 L2 | 400 EU2 |
| GAK.2000-4.D35 | 4938151 | FFH 1750 - 2000 | 8 | 1050 | • | • | 10 BD | 200 L2 | 400 EU2 |
| GAK.2000-4.D40 | 4938152 | FFH 1750 - 2000 | 8 | 1050 | • | • | 10 BD | 200 L2 | 400 EU2 |
| GAK.2000-4.D45 | 4938153 | FFH 1750 - 2000 | 8 | 1050 | • | • | 10 BD | 200 L2 | 400 EU2 |
| GAK.2000-4.D50 | 4938154 | FFH 1750 - 2000 | 8 | 1050 | • | • | 10 BD | 200 L2 | 400 EU2 |
| GAK.2225-4.D25 | 4938145 | FFH 1975 - 2225 | 9 | 1050 | • | • | 10 BD | 200 L2 | 400 EU2 |
| GAK.2225-4.D30 | 4938146 | FFH 1975 - 2225 | 9 | 1050 | • | • | 10 BD | 200 L2 | 400 EU2 |
| GAK.2225-4.D35 | 4938147 | FFH 1975 - 2225 | 9 | 1050 | • | • | 10 BD | 200 L2 | 900 EU2 |
| GAK.2225-4.D40 | 4938148 | FFH 1975 - 2225 | 9 | 1050 | • | • | 10 BD | 200 L2 | 400 EU2 |
| GAK.2225-4.D45 | 4938149 | FFH 1975 - 2225 | 9 | 1050 | • | • | 10 BD | 200 L2 | 400 EU2 |
| GAK.2225-4.D50 | 4938160 | FFH 1975 - 2225 | 9 | 1050 | • | • | 10 BD | 200 L2 | 400 EU2 |

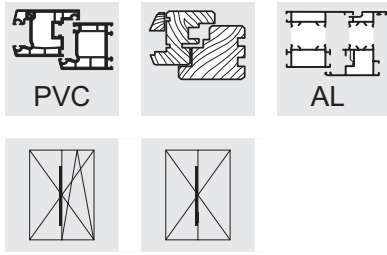

Double-sash drive rod GASK

- For constant handle position, in case of opposite fitting groove
- 1 piece
- Clampable in fitting groove
- Concealed lever, easily accessible
- 1-piece locking stroke similar to drive rod GAK or GAM
- Safety keeps are generally pre-assembled
- Adapter for functional elements DFE and TFE for mounting in security keeps – from GASK.945-1 and up



| Item designation | Item no. | Application range |  | VPA1 Pcs/type | VPA2 Pcs/type | VPA3 Pcs/type |
|------------------|----------|-------------------|---|------------------|------------------|------------------|
| GASK.710 | 4927021 | FFH 550 - 710 | 2 | 10 BD | 400 EA | |
| GASK.830-1 | 4927023 | FFH 580 - 830 | 3 | 10 BD | 400 EA | |
| GASK.945-1 | 4933702 | FFH 695 - 945 | 3 | 10 BD | 400 EA | |
| GASK.1100-1 | 4933703 | FFH 850 - 1100 | 4 | 10 BD | 400 EA | |
| GASK.1195-1 | 4998165 | FFH 945 - 1195 | 4 | 10 BD | 400 EA | |
| GASK.1325-1 | 4933705 | FFH 1075 - 1325 | 5 | 10 BD | 400 EA | |
| GASK.1325-2 | 4933706 | FFH 1075 - 1325 | 5 | 10 BD | 400 EA | |
| GASK.1550-1 | 4933707 | FFH 1300 - 1550 | 6 | 10 BD | 400 L1 | 900 EU2 |
| GASK.1550-2 | 4933708 | FFH 1300 - 1550 | 6 | 10 BD | 400 L1 | |
| GASK.1775-2 | 4933709 | FFH 1525 - 1775 | 7 | 10 BD | 400 L1 | |
| GASK.1775-3 | 4933720 | FFH 1525 - 1775 | 7 | 10 BD | 400 L1 | |
| GASK.2000-2 | 4933721 | FFH 1750 - 2000 | 9 | 10 BD | 400 L2 | 900 EU2 |
| GASK.2000-4 | 4933722 | FFH 1750 - 2000 | 9 | 10 BD | 400 L2 | 800 EU2 |
| GASK.2225-2 | 4933723 | FFH 1975 - 2225 | 9 | 10 BD | 400 L2 | 900 EU2 |
| GASK.2225-4 | 4933724 | FFH 1975 - 2225 | 9 | 10 BD | 400 L2 | 800 EU2 |
| GASK.2450-4 | 5068518 | FFH 2200 - 2450 | 10 | 10 BD | 400 L2 | |

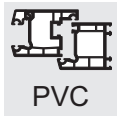

PVC



AL

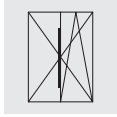

3

Double-sash drive rod GASK V < 700

- For constant handle position, in case of opposite fitting groove
- Locking gap less than 700 mm (V < 700)
- 1 piece
- Clampable in fitting groove
- Concealed lever, easily accessible
- 1-piece locking stroke similar to drive rod GAK or GAM
- Safety keeps are generally pre-assembled
- Adapter for functional elements DFE and TFE for mounting in security keeps – from GASK.945-1 and up



| Item designation | Item no. | Application range |  | VPA1 Pcs/type | VPA2 Pcs/type | VPA3 Pcs/type |
|------------------|----------|-------------------|---|------------------|------------------|------------------|
| GASK.830-1 | 4927023 | FFH 580 - 830 | 3 | 10 BD | 400 EA | |
| GASK.945-1 | 4933702 | FFH 695 - 945 | 3 | 10 BD | 400 EA | |
| GASK.1100-1 | 4933703 | FFH 850 - 1100 | 4 | 10 BD | 400 EA | |
| GASK.1325-2 | 4933706 | FFH 1075 - 1325 | 5 | 10 BD | 400 EA | |
| GASK.1550-2 | 4933708 | FFH 1300 - 1550 | 6 | 10 BD | 400 L1 | |
| GASK.1775-3 | 4933720 | FFH 1525 - 1775 | 7 | 10 BD | 400 L1 | |
| GASK.2000-4 | 4933722 | FFH 1750 - 2000 | 9 | 10 BD | 400 L2 | 800 EU2 |
| GASK.2225-4 | 4933724 | FFH 1975 - 2225 | 9 | 10 BD | 400 L2 | 800 EU2 |

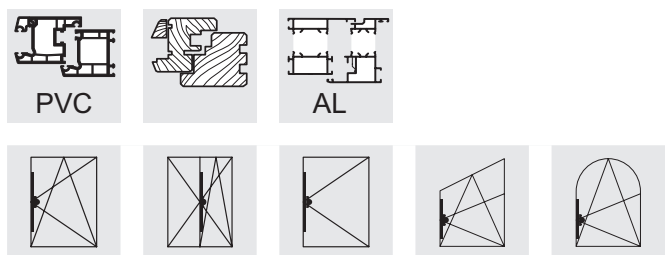

Drive rod GAM

- Central handle position
- Backset 15.5 mm
- Clampable in fitting groove
- Functional parts such as DFE and TFE retrofittable (see table), does not apply to activPilot Comfort
- For drilling and milling instructions see Group 15 installation drawings B-3-1
- Gear case for milling from rebate
- Gear case for mounting in drilled hole
- Fasten the window handle attachment with M5 x ..., DIN 965, 43 mm screw centres

drive rod GAM... BK

- With pre-assembled balcony door catch bolt
- Not suitable for activPilot Comfort / duoPort PAS



| Item designation | Item no. | Application range |  | DFE | TFE | VPA1 Pcs/type | VPA2 Pcs/type |
|------------------|----------|-------------------|---|-----|-----|------------------|------------------|
| GAM.800 | 4926267 | FFH 510 - 800 | 2 | | | 20 BD | 400 EA |
| GAM.1050 | 4926268 | FFH 710 - 1050 | 2 | • | • | 20 BD | 360 EA |
| GAM.1050-1 | 4926269 | FFH 710 - 1050 | 2 | • | • | 20 BD | 360 EA |
| GAM.1400 | 4926290 | FFH 900 - 1400 | 4 | • | • | 20 BD | 360 L1 |
| GAM.1400-1 | 4926291 | FFH 900 - 1400 | 4 | • | • | 20 BD | 360 L1 |
| GAM.1400-2 | 4926292 | FFH 900 - 1400 | 4 | • | • | 20 BD | 360 L1 |
| GAM.1800 | 4926293 | FFH 1300 - 1800 | 6 | • | • | 10 BD | 360 L1 |
| GAM.1800-2 | 4926295 | FFH 1300 - 1800 | 6 | • | • | 10 BD | 360 L1 |
| GAM.2300 | 4938161 | FFH 1800 - 2300 | 9 | • | • | 10 BD | 360 L2 |
| GAM.2300-3 | 4938163 | FFH 1800 - 2300 | 9 | • | • | 10 BD | 360 L2 |

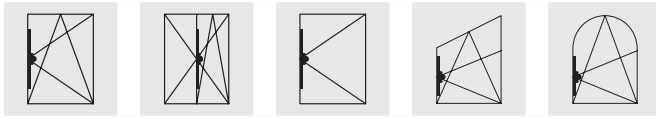
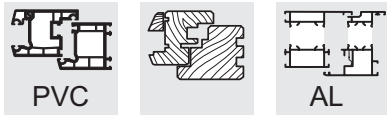

3

Drive rod GAM V < 700

- Central handle position
- Backset 15.5 mm
- Locking gap less than 700 mm (V < 700)
- Clampable in fitting groove
- Functional parts such as DFE and TFE retrofittable (see table), does not apply to activPilot Comfort
- For drilling and milling instructions see Group 15 installation drawings B-3-1
- Gear case for milling from rebate
- Gear case for mounting in drilled hole
- Fasten the window handle attachment with M5 x ..., DIN 965, 43 mm screw centres

drive rod GAM... BK

- With pre-assembled balcony door catch bolt
- Not suitable for activPilot Comfort / duoPort PAS

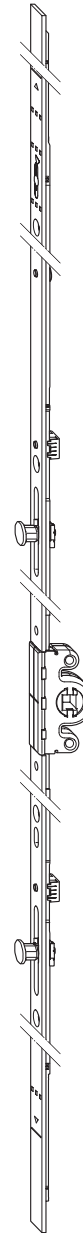

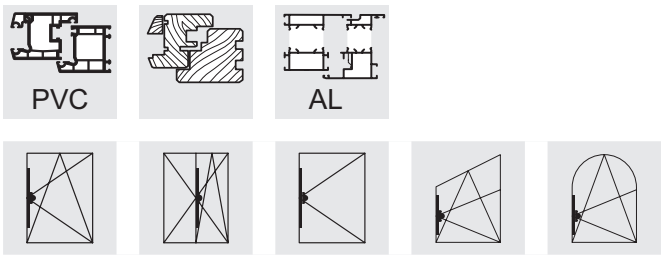

| Item designation | Item no. | Application range |  | DFE | TFE | VPA1 Pcs/type | VPA2 Pcs/type |
|------------------|----------|-------------------|---|-----|-----|------------------|------------------|
| GAM.1400-2 | 4926292 | FFH 900 - 1400 | 4 | • | • | 20 BD | 360 L1 |
| GAM.1800-2 | 4926295 | FFH 1300 - 1800 | 6 | • | • | 10 BD | 360 L1 |
| GAM.2300-3 | 4938163 | FFH 1800 - 2300 | 9 | • | • | 10 BD | 360 L2 |

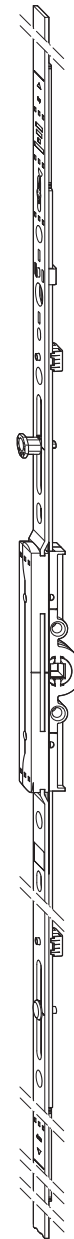

Drive rod GAM ... D 7.5

- Central handle position
- Backset 7.5 mm
- Clampable in fitting groove
- Functional parts such as DFE and TFE retrofittable (see table), does not apply to activPilot Comfort
- For drilling and milling instructions see Group 15 installation drawings B-3-2
- Gear case for milling from rebate
- Gear case for mounting in drilled hole
- Fasten the window handle attachment with M5 x ..., DIN 965, 43 mm screw centres



| Item designation | Item no. | Application range |  | DFE | TFE | VPA1 Pcs/type | VPA2 Pcs/type | VPA3 Pcs/type |
|------------------|----------|-------------------|---|-----|-----|------------------|------------------|------------------|
| GAM.800.D7,5 | 4969404 | FFH 575 - 800 | 2 | | | 20 BD | 400 EA | |
| GAM.1050-1.D7,5 | 4969403 | FFH 710 - 1050 | 2 | • | • | 20 BD | 360 EA | |
| GAM.1400-1.D7,5 | 4969402 | FFH 900 - 1400 | 4 | • | • | 20 BD | 360 L1 | |
| GAM.1400-2.D7,5 | 4969401 | FFH 900 - 1400 | 4 | • | • | 20 BD | 360 L1 | |
| GAM.1800-2.D7,5 | 4969400 | FFH 1300 - 1800 | 6 | • | • | 10 BD | 360 L1 | |
| GAM.2300-3.D7,5 | 4969289 | FFH 1800 - 2300 | 9 | • | • | 10 BD | 360 L2 | 900 EU2 |

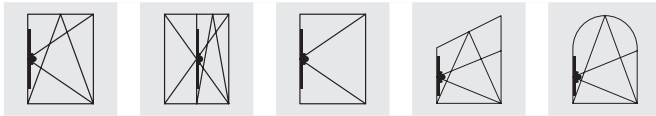
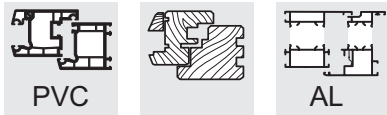

3

Drive rod GAM ... D 7.5 V < 700

- Central handle position
- Backset 7.5 mm
- Locking gap less than 700 mm (V < 700)
- Clampable in fitting groove
- Functional parts such as DFE and TFE retrofittable (see table), does not apply to activPilot Comfort
- For drilling and milling instructions see Group 15 installation drawings B-3-2
- Gear case for milling from rebate
- Gear case for mounting in drilled hole
- Fasten the window handle attachment with M5 x ..., DIN 965, 43 mm screw centres

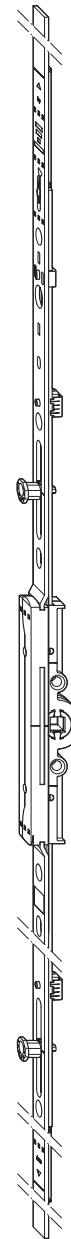

| Item designation | Item no. | Application range |  | DFE | TFE | VPA1 Pcs/type | VPA2 Pcs/type | VPA3 Pcs/type |
|------------------|----------|-------------------|---|-----|-----|------------------|------------------|------------------|
| GAM.1400-2.D7,5 | 4969401 | FFH 900 - 1400 | 4 | • | • | 20 BD | 360 L1 | |
| GAM.1800-2.D7,5 | 4969400 | FFH 1300 - 1800 | 6 | • | • | 10 BD | 360 L1 | |
| GAM.2300-3.D7,5 | 4969289 | FFH 1800 - 2300 | 9 | • | • | 10 BD | 360 L2 | 900 EU2 |

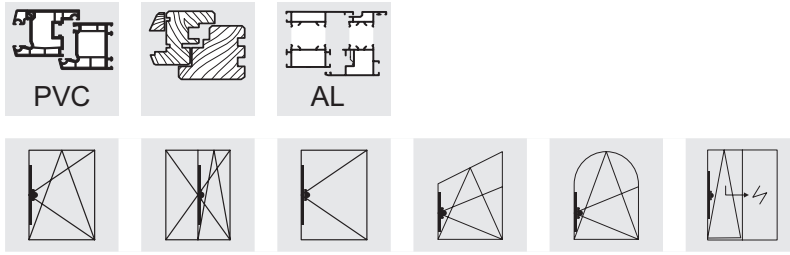

Drive rod GAM ... D 25 - 50

- Central handle position
- The backset is optionally 25, 30, 35, 40, 45 or 50 mm
- Clampable in fitting groove
- Functional parts such as DFE and TFE retrofittable (see table), does not apply to activPilot Comfort
- For drilling and milling instructions see group 15, installation drawings B-3-4
- Extensible with extension rods
- Gear case for milling from rebate

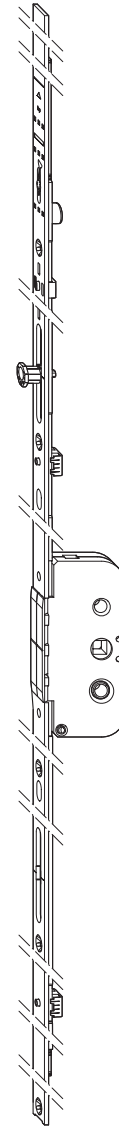

| Item designation | Item no. | Application range |  | DFE | TFE | VPA1 Pcs/type | VPA2 Pcs/type | VPA3 Pcs/type |
|------------------|----------|-------------------|---|-----|-----|------------------|------------------|------------------|
| GAM.800.D25 | 4941067 | FFH 510 - 800 | 2 | | | 10 BD | 200 EA | |
| GAM.800.D30 | 4941069 | FFH 510 - 800 | 2 | | | 10 BD | 200 EA | |
| GAM.1050-1.D25 | 4941081 | FFH 710 - 1050 | 2 | • | • | 10 BD | 200 EA | |
| GAM.1050-1.D30 | 4941082 | FFH 710 - 1050 | 2 | • | • | 10 BD | 200 EA | |
| GAM.1400-1.D25 | 4927159 | FFH 900 - 1400 | 4 | • | • | 10 BD | 200 L1 | |
| GAM.1400-1.D30 | 4927171 | FFH 900 - 1400 | 4 | • | • | 10 BD | 200 L1 | |
| GAM.1400-1.D35 | 4927172 | FFH 900 - 1400 | 4 | • | • | 10 BD | 200 L1 | |
| GAM.1400-1.D40 | 4927173 | FFH 900 - 1400 | 4 | • | • | 10 BD | 200 L1 | |
| GAM.1400-1.D45 | 4927174 | FFH 900 - 1400 | 4 | • | • | 10 BD | 200 L1 | |
| GAM.1400-1.D50 | 4927175 | FFH 900 - 1400 | 4 | • | • | 10 BD | 200 L1 | |
| GAM.1400-2.D25 | 4933312 | FFH 900 - 1400 | 4 | • | • | 10 BD | 200 L1 | |
| GAM.1400-2.D30 | 4933313 | FFH 900 - 1400 | 4 | • | • | 10 BD | 200 L1 | |
| GAM.1400-2.D35 | 4933315 | FFH 900 - 1400 | 4 | • | • | 10 BD | 200 L1 | |
| GAM.1400-2.D40 | 4933316 | FFH 900 - 1400 | 4 | • | • | 10 BD | 200 L1 | |
| GAM.1400-2.D45 | 4933317 | FFH 900 - 1400 | 4 | • | • | 10 BD | 200 L1 | |
| GAM.1800-2.D25 | 4933319 | FFH 1300 - 1800 | 6 | • | • | 10 BD | 200 L1 | |
| GAM.1800-2.D30 | 4933340 | FFH 1300 - 1800 | 6 | • | • | 10 BD | 200 L1 | |
| GAM.1800-2.D35 | 4933341 | FFH 1300 - 1800 | 6 | • | • | 10 BD | 200 L1 | |
| GAM.1800-2.D40 | 4933342 | FFH 1300 - 1800 | 6 | • | • | 10 BD | 200 L1 | |
| GAM.1800-2.D45 | 4933343 | FFH 1300 - 1800 | 6 | • | • | 10 BD | 200 L1 | |
| GAM.2300-3.D25 | 4938167 | FFH 1800 - 2300 | 9 | • | • | 10 BD | 200 L2 | 900 EU2 |
| GAM.2300-3.D30 | 4938168 | FFH 1800 - 2300 | 9 | • | • | 10 BD | 200 L2 | 400 EU2 |
| GAM.2300-3.D35 | 4938169 | FFH 1800 - 2300 | 9 | • | • | 10 BD | 200 L2 | 400 EU2 |
| GAM.2300-2.D40 | 4936028 | FFH 1800 - 2300 | 9 | • | • | 10 BD | 200 L2 | |
| GAM.2300-3.D40 | 4938170 | FFH 1800 - 2300 | 9 | • | • | 10 BD | 200 L2 | |
| GAM.2300-3.D45 | 4938427 | FFH 1800 - 2300 | 9 | • | • | 10 BD | 200 L2 | 400 EU2 |
| GAM.2300-3.D50 | 4938428 | FFH 1800 - 2300 | 9 | • | • | 10 BD | 200 L2 | 900 EU2 |

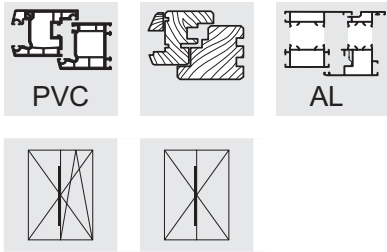

3

Double-sash drive rod GASM

- Central handle position with opposing eurogroove
- 1 piece
- GASM.1050 is always used in combination with corner drive E3.
- Clampable in fitting groove
- Concealed lever, easily accessible
- 1-piece locking stroke similar to drive rod GAK or GAM
- Safety keeps are generally pre-assembled
- Adapters for functional parts DFE and TFE can be fitted to security keeps - from GASM.1050-1 onwards (not applicable to activPilot Comfort!)

Double sash drive rod GASM ... L

- As described above, but with long lever

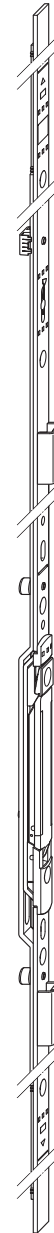

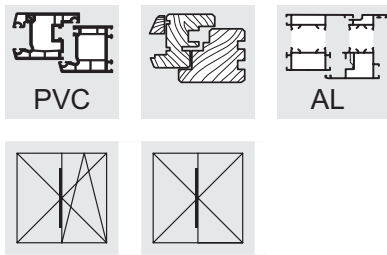

| Item designation | Item no. | Application range |  | VPA1 Pcs/type | VPA2 Pcs/type | VPA3 Pcs/type |
|------------------|----------|-------------------|---|------------------|------------------|------------------|
| GASM.800 | 4927112 | FFH 560 - 800 | 3 | 10 BD | 400 EA | |
| GASM.1050-1.E3 | 4933666 | FFH 710 - 1050 | 4 | 10 BD | 400 EA | |
| GASM.1400-1 | 4933667 | FFH 900 - 1400 | 5 | 10 BD | 400 L1 | |
| GASM.1400-2 | 4933668 | FFH 900 - 1400 | 5 | 10 BD | 400 L1 | |
| GASM.1400-2.L | 4936721 | FFH 900 - 1400 | 5 | 10 BD | 400 L1 | |
| GASM.1800-2 | 4933700 | FFH 1300 - 1800 | 7 | 10 BD | 400 L1 | |
| GASM.2300-3 | 4933701 | FFH 1800 - 2300 | 9 | 10 BD | 400 L2 | 900 EU2 |

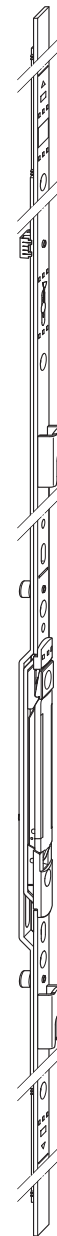

Double-sash drive rod GASM V < 700

- Central handle position with opposing eurogroove
- Locking gap less than 700 mm (V < 700)
- 1 piece
- Clampable in fitting groove
- Concealed lever, easily accessible
- 1-piece locking stroke similar to drive rod GAK or GAM
- Safety keeps are generally pre-assembled
- Adapters for functional parts DFE and TFE can be fitted to security keeps – from GASM.1050-1 onwards (not applicable to activPilot Comfort!)



| Item designation | Item no. | Application range |  | VPA1 Pcs/type | VPA2 Pcs/type | VPA3 Pcs/type |
|------------------|----------|-------------------|---|------------------|------------------|------------------|
| GASM.1400-2 | 4933668 | FFH 900 - 1400 | 5 | 10 BD | 400 L1 | |
| GASM.1800-2 | 4933700 | FFH 1300 - 1800 | 7 | 10 BD | 400 L1 | |
| GASM.2300-3 | 4933701 | FFH 1800 - 2300 | 9 | 10 BD | 400 L2 | 900 EU2 |

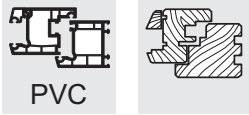

PVC



4

Corner drive E1.N

- Bracket length 98.5 mm
- Automatic and manual assembly possible
- Smooth operation, due to rust-free spring steel hinges inserted in C-rail
- With supporting element to fix in the fitting groove of the sash

Corner drive E11.N

- Same construction as E1.N with an additional octagonal bolt on the second arm

Corner drive E1.PA

- See above
- Separate positioning plug for adjusting the SBK...PA tilt keep
- Not clampable in fitting groove

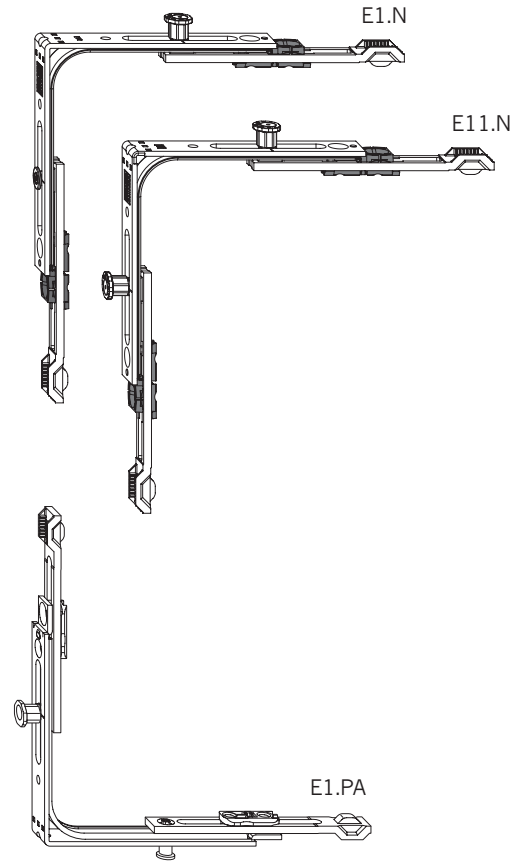

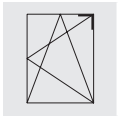
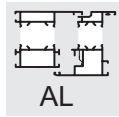
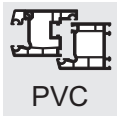

| Item designation | Item no. |  | VPA1 Pcs/type | VPA2 Pcs/type |
|------------------|----------|---|------------------|------------------|
| E1.N | 5019146 | 4 | 100 KK | 2400 EK |
| E11.N | 5051287 | 4 | 100 KK | 2400 EK |
| E1.PA | 4966485 | 4 | 100 KK | 2400 EK |

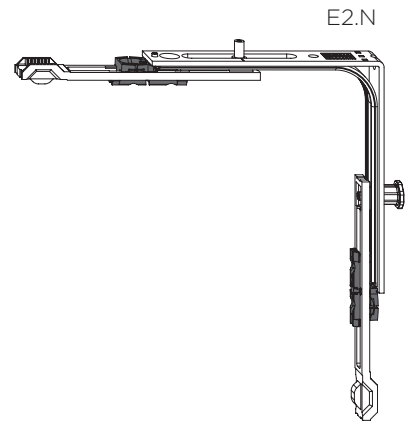

Corner drive E2.N

- Coupled with OS2 on the hinge side
- Bracket length 98.5 mm
- Automatic and manual assembly possible
- Smooth operation, due to rust-free spring steel hinges inserted in C-rail
- With supporting element to fix in the fitting groove of the sash



| Item designation | Item no. |  | VPA1 Pcs/type | VPA2 Pcs/type |
|------------------|----------|---|------------------|------------------|
| E2.N | 5019147 | 4 | 100 KK | 2400 EK |

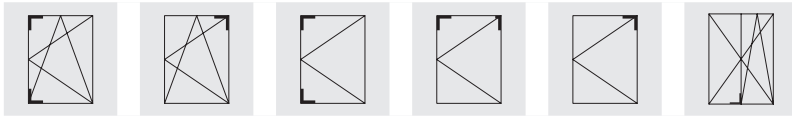
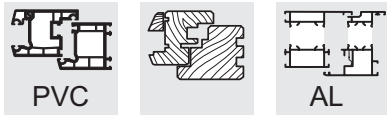

4

Corner drive E3

- Bracket length 98.5 mm (on one side)
- With shortened bracket on one side
- Automatic and manual assembly possible
- Smooth operation, due to rust-free spring steel hinges inserted in C-rail
- The screw for fixing the adjoining faceplate (on the short piece) with the corner drive is included in the scope of delivery.

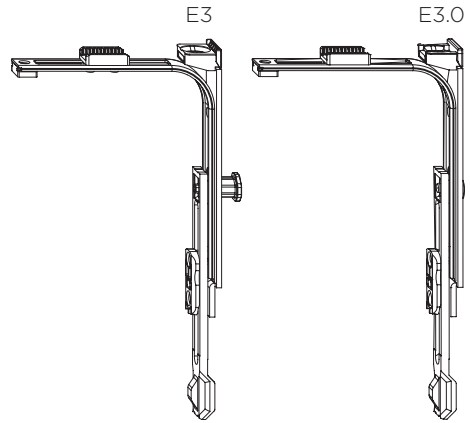

Corner drive E3.F

- Same design as E3, but clampable in the fitting groove

Corner drive E3.L

- Automatic mounting carried out by Lemuth
- Corner piece for diagonal screw connection

Corner drive E3.F.L

- Same design as E3.L, but clampable

Corner drive E3.0

- Design identical to E3, but without locking pin

| Item designation | Item no. |  | VPA1 Pcs/type | VPA2 Pcs/type |
|------------------|----------|---|------------------|------------------|
| E3 | 2842244 | 3 | 100 KK | 2400 EK |
| E3.F | 4929791 | 3 | 100 KK | 2400 EK |
| E3.L | 4927430 | 3 | 100 KK | 2400 EK |
| E3.F.L | 5009086 | 3 | 100 KK | 2400 EK |
| E3.0.ZN | 5034800 | 3 | 100 KK | 2400 EK |

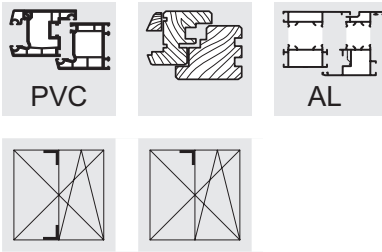

Corner drive E1.SBS

- For installation into the inactive (second-opening) sash with opposing eurogroove when an E11 corner drive is used for the sash opened first.
- With security keep welded to the vertical arm
- Bracket length 98.5 mm
- Automatic and manual assembly possible
- Smooth operation, due to rust-free spring steel hinges inserted in C-rail

Corner drive E1.SBS.O

- For installation into the inactive sash (top area)

Corner drive E1.SBS.U

- For installation into the inactive sash (bottom area)

Corner drive E1.SBS...F

- Clampable design

Corner drive E1.SBS.O.RC.F

- See above
- With slide lock (beneath the welded keep) against manipulation when the turn-tilt sash is locked.
- Clampable design

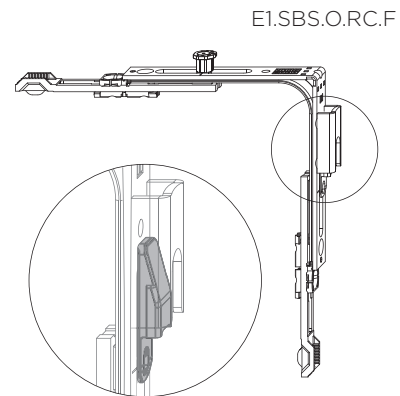
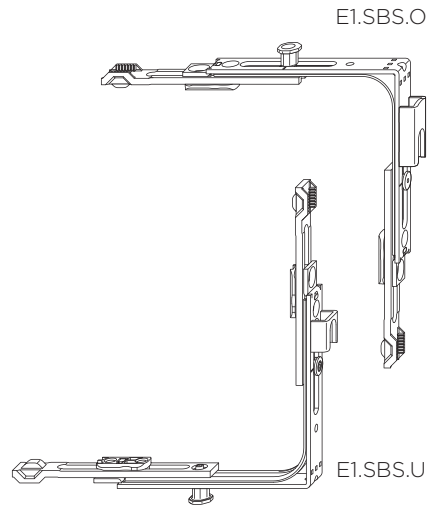

| Item designation | Item no. |  | VPA1 Pcs/type | VPA2 Pcs/type |
|------------------|----------|---|------------------|------------------|
| E1.SBS.O | 4964898 | 4 | 100 KK | 2400 EK |
| E1.SBS.O.F | 4964900 | 4 | 100 KK | 2400 EK |
| E1.SBS.U | 4964899 | 4 | 100 KK | 2400 EK |
| E1.SBS.U.F | 4964901 | 4 | 100 KK | 2400 EK |
| E1.SBS.O.RC.F | 5037101 | 4 | 100 KK | 2400 EK |

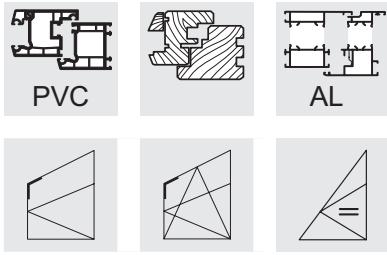

4

Corner drive E1.A

- Used for non right-angled corners on sashes
- Adjustable angle setting
- Smooth operation, due to rust-free spring steel hinges inserted in C-rail

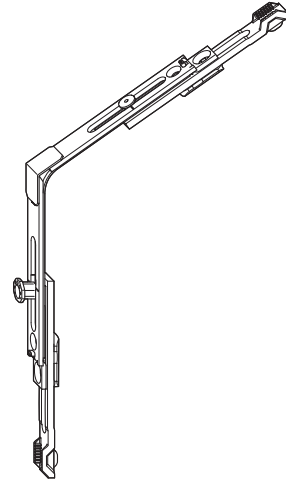

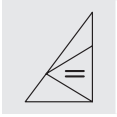
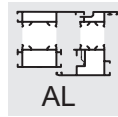
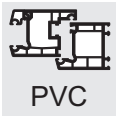

| Item designation | Item no. |  | VPA1 Pcs/type | VPA2 Pcs/type |
|------------------|----------|---|------------------|------------------|
| E1.A | 4926350 | 4 | 100 KK | 2400 EK |

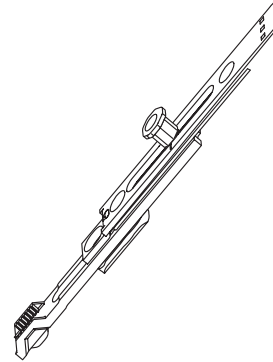

Connecting rail ASS.AS.1

- One-piece end part with locking point
- Bracket length identical to corner drive E1



| Item designation | Item no. |  | VPA1 Pcs/type | VPA2 Pcs/type |
|------------------|----------|---|------------------|------------------|
| ASS.AS.1 | 4937603 | 2 | 150 KK | 3600 EK |

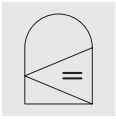
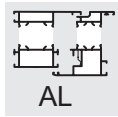
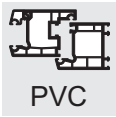

4

Connecting rail AARB.1000-3

- For round-arch windows
- 3 locking points
- Can be used left and right hand

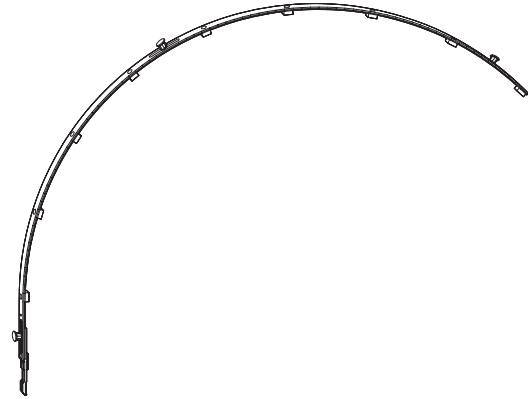

| Item designation | Item no. | VPA1 Pcs/type | VPA2 Pcs/type |
|------------------|----------|------------------|------------------|
| AARB.1000-3 | 4927284 | 10 BD | 400 EA |

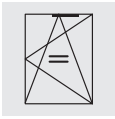
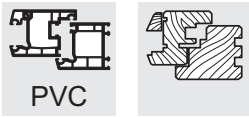

Top rod OS1.PA.600



- In combination with shears SK1.PA.../SC1.PA...
- After assembly the top rod and the shear are firmly attached to one another
- Clampable in fitting groove
- Integrated anti-slam block in tilt position as standard
- OS1.PA.600 is always combined with an E3 corner drive on the hinge side

Top rod OS2.PA...

- In combination with shears SK2.PA.../SC2.PA...
- OS2 ... is used in combination with E2 on the hinge side
- Progressive shear retraction: adjustable from 18 to 25 mm

Tilt limiter KBG.OS

- See Group 10, accessories

Anti-slam device ZSS.OS

- See Group 10, accessories



| Item designation | Item no. | Application range |  | VPA1 Pcs/type | VPA2 Pcs/type |
|------------------|----------|-------------------|---|------------------|------------------|
| OS1.PA.600 | 4965080 | FFB 460 - 600 | 1 | 20 BD | 800 EA |
| OS2.PA.800 | 4965081 | FFB 601 - 800 | 2 | 20 BD | 800 EA |
| OS2.PA.1025-1 | 4965082 | FFB 801 - 1025 | 3 | 20 BD | 500 EA |

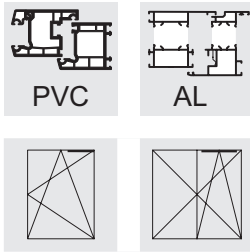

5

Top rod OS2

- OS2 ... is used in combination with E2 on the hinge side
- In combination with shears SC2/SK2/SH2/SHW2
- After assembly the top rod and the shear are firmly attached to one another
- Clampable in fitting groove
- Progressive shear retraction: adjustable from 18 to 25 mm
- Integrated anti-slam block in tilt position as standard
- From 1475 mm sash rebate width with additional shear ZSR

| Item designation | Item no. | Application range |  | VPA1 Pcs/type | VPA2 Pcs/type |
|------------------|----------|-------------------|---|------------------|------------------|
| OS2.800 | 4928979 | FFB 600 - 800 | 4 | 20 BD | 800 EA |
| OS2.1025 | 2849278 | FFB 775 - 1025 | 5 | 20 BD | 500 EA |
| OS2.1025-1 | 2848275 | FFB 775 - 1025 | 5 | 20 BD | 500 EA |
| OS2.1250-1 | 2848291 | FFB 1000 - 1250 | 6 | 20 BD | 500 EA |
| OS2.1475-1 | 2848304 | FFB 1225 - 1475 | 6 | 20 BD | 500 L1 |

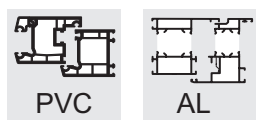

Corner hinges EL.CS

- Used in combination with overlap sash hinges FLC or rebate sash hinges FLC-W / FLC.PA
- Large support area underneath the tilt axis
- For drilling instructions see group 15, installation drawings
- For sash weight see overview of articles
- Side adjustment ± 2 mm

Corner hinge cover K.EL.CS

- See separate product page

EL.CS

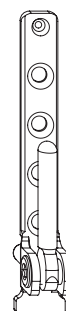

K.EL.CS



| Item designation | Item no. |  | Max. sash weight (kg) | VPA1 Pcs/type | VPA2 Pcs/type |
|------------------|----------|---|-----------------------|------------------|------------------|
| EL.CS.3-3-3 | 5064222 | 4 | 80 | 300 KK | 2400 EK |
| EL.CS.3-3-3.BR | 5064225 | 4 | 80 | 300 KK | 2400 EK |
| EL.CS.3-3-3.F9 | 5064224 | 4 | 80 | 300 KK | 2400 EK |
| EL.CS.3-3-3.WS | 5064223 | 4 | 80 | 300 KK | 2400 EK |
| EL.CS.6-3-3 | 5064226 | 4 | 100 | 300 KK | 2400 EK |
| EL.CS.6-3-3.BR | 5064229 | 4 | 100 | 300 KK | 2400 EK |
| EL.CS.6-3-3.F9 | 5064228 | 4 | 100 | 300 KK | 2400 EK |
| EL.CS.6-3-3.WS | 5064227 | 4 | 100 | 300 KK | 2400 EK |
| EL.CS.6-3-10 | 5064230 | 4 | 100 | 300 KK | 2400 EK |
| EL.CS.6-3-10.BR | 5064233 | 4 | 100 | 300 KK | 2400 EK |
| EL.CS.6-3-10.F9 | 5064232 | 4 | 100 | 300 KK | 2400 EK |
| EL.CS.6-3-10.WS | 5064231 | 4 | 100 | 300 KK | 2400 EK |
| EL.CS.6-3-22 | 5064234 | 4 | 130/150 | 300 KK | 2400 EK |
| EL.CS.6-3-22.BR | 5064237 | 4 | 130/150 | 300 KK | 2400 EK |
| EL.CS.6-3-22.F9 | 5064236 | 4 | 130/150 | 300 KK | 2400 EK |
| EL.CS.6-3-22.WS | 5064235 | 4 | 130/150 | 300 KK | 2400 EK |
| EL.CS.6-10-10.WS | 5064238 | 4 | 100 | 300 KK | 2400 EK |
| EL.CS.6-22-3 | 5064239 | 4 | 130/150 | 300 KK | 2400 EK |
| EL.CS.6-22-3.BR | 5064241 | 4 | 130/150 | 300 KK | 2400 EK |
| EL.CS.6-22-3.WS | 5064240 | 4 | 130/150 | 300 KK | 2400 EK |

WS = white; BR = brown, F9 = titanium coloured

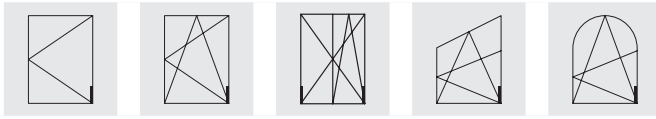
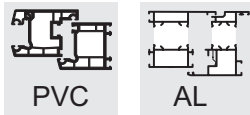

Corner hinges EL.CS-W

6

- Used in combination with rebate sash hinges FL.C-W / FL.C.PA
- Large support area underneath the tilt axis
- For drilling instructions see group 15, installation drawings
- Sash weight see Table of articles
- Side adjustment ± 2 mm
- With bolt support (max. parallel position of the bolt towards the corner hinge plate) avoids unintentional contact of the sash hinge roll and the corner hinge plate

- Recommendation for use: unfavourable sash formats, e. g.
- FFB > 1000 mm
- Sash rebate width: FFH > 1:1

Corner hinge cover K.EL.CS

- See separate product page

EL.CS-W

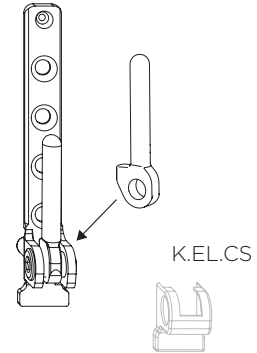

| Item designation | Item no. |  | Max. sash weight (kg) | VPA1 Pcs/type | VPA2 Pcs/type |
|--------------------|----------|---|-----------------------|------------------|------------------|
| EL.CS-W.6-3-3 | 5064244 | 4 | 100 | 300 KK | 2400 EK |
| EL.CS-W.6-3-3.F9 | 5064246 | 4 | 100 | 300 KK | 2400 EK |
| EL.CS-W.6-3-3.WS | 5064245 | 4 | 100 | 300 KK | 2400 EK |
| EL.CS-W.6-3-10 | 5064247 | 4 | 100 | 300 KK | 2400 EK |
| EL.CS-W.6-3-10.F9 | 5064249 | 4 | 100 | 300 KK | 2400 EK |
| EL.CS-W.6-3-10.WS | 5064248 | 4 | 100 | 300 KK | 2400 EK |
| EL.CS-W.6-3-22 | 5064250 | 4 | 130/150 | 300 KK | 2400 EK |
| EL.CS-W.6-3-22.F9 | 5064252 | 4 | 130/150 | 300 KK | 2400 EK |
| EL.CS-W.6-3-22.WS | 5064251 | 4 | 130/150 | 300 KK | 2400 EK |
| EL.CS-W.6-10-10.WS | 5064253 | 4 | 100 | 300 KK | 2400 EK |
| EL.CS-W.6-22-3 | 5064254 | 4 | 130/150 | 300 KK | 2400 EK |
| EL.CS-W.6-22-3.WS | 5064255 | 4 | 130/150 | 300 KK | 2400 EK |

WS = white; BR = brown, F9 = titanium coloured

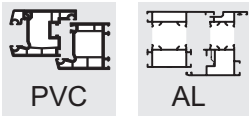

Corner hinge cap K.EL.CS

- Cover for narrow corner hinges EL.CS...
- For visual cover of the bottom area of the corner hinge
- Can be used left and right hand
- Available in different colours

EL.CS

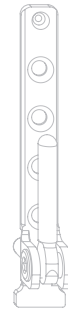

K.EL.CS



| Item designation | Item no. | VPA1 Pcs/type | VPA2 Pcs/type | VPA3 Pcs/type |
|------------------|----------|------------------|------------------|------------------|
| K.EL.CS.BR | 5065117 | 100 BL | 1000 KK | 8000 EK |
| K.EL.CS.BZ-CN | 5065504 | 100 BL | 1000 KK | 8000 EK |
| K.EL.CS.BZ-RB | 5065508 | 100 BL | 1000 KK | 8000 EK |
| K.EL.CS.CW | 5065509 | 100 BL | 1000 KK | 8000 EK |
| K.EL.CS.F1 | 5065521 | 100 BL | 1000 KK | 8000 EK |
| K.EL.CS.F1-ELOX | 5065522 | 100 BL | 1000 KK | 8000 EK |
| K.EL.CS.F3 | 5065524 | 100 BL | 1000 KK | 8000 EK |
| K.EL.CS.F3-MG | 5065525 | 100 BL | 1000 KK | 8000 EK |
| K.EL.CS.F9 | 5065527 | 100 BL | 1000 KK | 8000 EK |
| K.EL.CS.LBR | 5065529 | 100 BL | 1000 KK | 8000 EK |
| K.EL.CS.LGR | 5065536 | 100 BL | 1000 KK | 8000 EK |
| K.EL.CS.PW | 5065537 | 100 BL | 1000 KK | 8000 EK |
| K.EL.CS.SW | 5065538 | 100 BL | 1000 KK | 8000 EK |
| K.EL.CS.UN77078 | 5065539 | 100 BL | 1000 KK | 8000 EK |
| K.EL.CS.WS | 5065119 | 100 BL | 1000 KK | 8000 EK |

AGR = anthracite grey, BR = brown, BZ-AM = bronze - antique brass, BZ-RB = bronze - red brown, BZ-CU = bronze coppery, CW = cream white, EV1 = anodised silver, F1 = silver colour, F1-elox = sim. to F1 anodised silver, F3 = gold colour, F3-MG = gold mat, F9 = titanium-coloured, LBR = clay brown, PW = pearl white, SG = silver grey, SGB = grey, SGR = dust grey, SL = silver look (galvanised), SW = deep black, WS = white

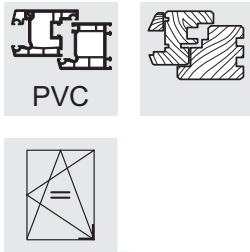

Sash hinges FL.C.PADK.20-13

- Height adjustment ± 3 mm
- Central fastening as standard
- Turn position is the factory default
- Overlapping system linkage without connecting plates
- In combination with corner hinges EL.CS, EL.CS-W, EL.HC.PA
- Parallel action possible via the control curve
- Operating sequence: locked – tilt position – parallel action – turn position



6

Sash hinge cover K.FLC-W

- Available in different colours

Sash hinge plug S.FLC-W

- Can be used left and right hand
- Dirt protection for height adjustment device
- Available in different colours

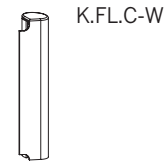

| Item designation | Item no. |  | Max. sash weight (kg) | Overlap | Groove centre position | VPA1 Pcs/type | VPA2 Pcs/type | VPA3 Pcs/type |
|-----------------------|----------|---|-----------------------|---------|------------------------|---------------|---------------|---------------|
| FL.C.PADK.20-13.LS | 5069170 | 4 | 100 | 20 | 13 | 20 KK | 160 EK | |
| FL.C.PADK.20-13.RS | 5069169 | 4 | 100 | 20 | 13 | 20 KK | 160 EK | |
| FL.C.PADK.20-13.LS.F9 | 5069174 | 4 | 100 | 20 | 13 | 20 KK | 160 EK | |
| FL.C.PADK.20-13.RS.F9 | 5069173 | 4 | 100 | 20 | 13 | 20 KK | 160 EK | |
| FL.C.PADK.20-13.LS.WS | 5069172 | 4 | 100 | 20 | 13 | 20 KK | 160 EK | |
| FL.C.PADK.20-13.RS.WS | 5069171 | 4 | 100 | 20 | 13 | 20 KK | 160 EK | |
| K.FLC-W.LS.BR | 5065127 | | | | | 100 BL | 300 KK | 2400 EK |
| K.FLC-W.RS.BR | 5065126 | | | | | 100 BL | 300 KK | 2400 EK |
| K.FLC-W.LS.BZ-AM | 5065575 | | | | | 100 BL | 300 KK | 2400 EK |
| K.FLC-W.RS.BZ-AM | 5065574 | | | | | 100 BL | 300 KK | 2400 EK |
| K.FLC-W.LS.BZ-RB | 5065577 | | | | | 100 BL | 300 KK | 2400 EK |
| K.FLC-W.RS.BZ-RB | 5065576 | | | | | 100 BL | 300 KK | 2400 EK |
| K.FLC-W.LS.CW | 5065579 | | | | | 100 BL | 300 KK | 2400 EK |
| K.FLC-W.RS.CW | 5065578 | | | | | 100 BL | 300 KK | 2400 EK |
| K.FLC-W.LS.F1 | 5065581 | | | | | 100 BL | 300 KK | 2400 EK |
| K.FLC-W.RS.F1 | 5065580 | | | | | 100 BL | 300 KK | 2400 EK |
| K.FLC-W.LS.F1-ELOX | 5065583 | | | | | 100 BL | 300 KK | 2400 EK |
| K.FLC-W.RS.F1-ELOX | 5065582 | | | | | 100 BL | 300 KK | 2400 EK |
| K.FLC-W.LS.F3 | 5065603 | | | | | 100 BL | 300 KK | 2400 EK |
| K.FLC-W.RS.F3 | 5065602 | | | | | 100 BL | 300 KK | 2400 EK |
| K.FLC-W.LS.F9 | 5065605 | | | | | 100 BL | 300 KK | 2400 EK |
| K.FLC-W.RS.F9 | 5065604 | | | | | 100 BL | 300 KK | 2400 EK |
| K.FLC-W.LS.SW | 5065607 | | | | | 100 BL | 300 KK | 2400 EK |
| K.FLC-W.RS.SW | 5065606 | | | | | 100 BL | 300 KK | 2400 EK |
| K.FLC-W.LS.WS | 5065129 | | | | | 100 BL | 300 KK | 2400 EK |
| K.FLC-W.RS.WS | 5065128 | | | | | 100 BL | 300 KK | 2400 EK |
| S.FLC-W.BR | 5065613 | | | | | 500 BL | 3000 KK | 24000 EK |
| S.FLC-W.F1 | 5065614 | | | | | 500 BL | 3000 KK | 24000 EK |
| S.FLC-W.F9 | 5065615 | | | | | 500 BL | 3000 KK | 24000 EK |
| S.FLC-W.WS | 5065616 | | | | | 500 BL | 3000 KK | 24000 EK |

RS = right, LS = left

WS = white, BR = brown, SL = silver, EV1 = anodised silver, F1 = silver colour, F3 = gold colour, BZ-RB = bronze red brown, F9 = titanium coloured, CW = cream white

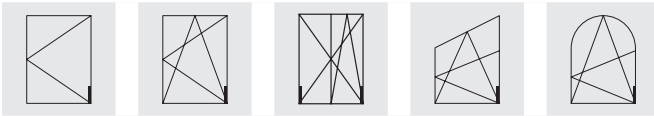
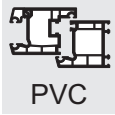

Sash hinges FL.C

- Overlap sash hinge
- Used in combination with corner hinge EL.C..(large version) or EL.CS (narrow version)
- Bottom positioning plug out of steel with a length of 28 mm for an optimum weight transfer
- For drilling instructions see group 15, installation drawings
- Sash weight see Table of articles
- Height adjustment ± 3 mm

Sash hinge FL.C-A

- Overlap sash hinge with pressure adjustment
- Pressure adjustment ± 0.8 mm

Sash hinge FL.C-F

- Overlap sash hinge with adjustable turn restriction

Sash hinge cover K.FL.C-DS

- See separate product page

Sash hinge plug S.FL.C

- See separate product page

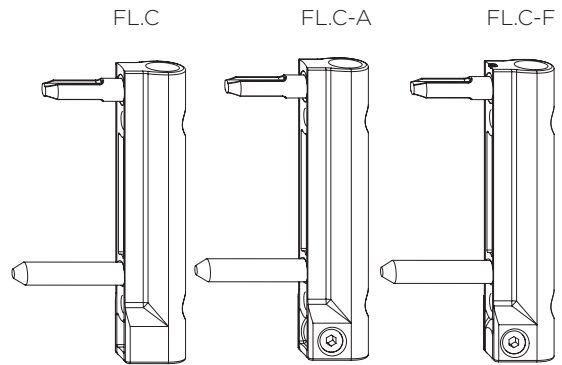

S.FL.C

K.FL.C-DS

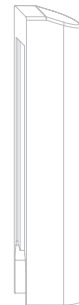

| Item designation | Item no. |  | Max. sash weight (kg) | VPA1 Pcs/type | VPA2 Pcs/type |
|-------------------|----------|---|-----------------------|------------------|------------------|
| FL.C.20-6-28 | 5097183 | 2 | 130/150 | 250 KK | 6000 EK |
| FL.C.20-6-28.BR | 5097186 | 2 | 130/150 | 250 KK | 6000 EK |
| FL.C.20-6-28.CW | 5097187 | 2 | 130/150 | 250 KK | 6000 EK |
| FL.C.20-6-28.F9 | 5097185 | 2 | 130/150 | 250 KK | 6000 EK |
| FL.C.20-6-28.WS | 5097184 | 2 | 130/150 | 250 KK | 6000 EK |
| FL.C-A.20-6-11/28 | 5097189 | 2 | 130/150 | 250 KK | 6000 EK |
| FL.C-A.20-6-28 | 5097197 | 2 | 130/150 | 250 KK | 6000 EK |
| FL.C-A.20-6-28.BR | 5097229 | 2 | 130/150 | 250 KK | 6000 EK |
| FL.C-A.20-6-28.F9 | 5097228 | 2 | 130/150 | 250 KK | 6000 EK |
| FL.C-A.20-6-28.WS | 5097227 | 2 | 130/150 | 250 KK | 6000 EK |
| FL.C-F.20-6-28 | 5097190 | 2 | 130/150 | 250 KK | 6000 EK |
| FL.C-F.20-6-28.BR | 5097193 | 2 | 130/150 | 250 KK | 6000 EK |
| FL.C-F.20-6-28.F9 | 5081320 | 2 | 130/150 | 250 KK | 6000 EK |
| FL.C-F.20-6-28.WS | 5081319 | 2 | 130/150 | 250 KK | 6000 EK |

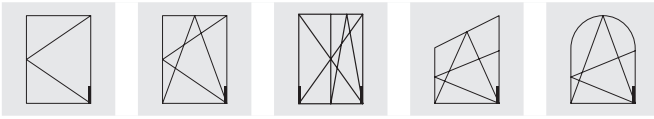
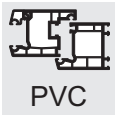

Sash hinge cover K.FL.C-DS

- Cover for overlap sash hinge FL.C, FL.C-A , FL.C-F
- Can be used left and right hand
- Available in different colours

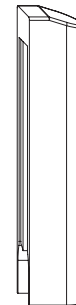

K.FL.C-DS

Sash hinge plug S.FL.C

- Plug for overlap sash hinge FL.C
- Can be used left and right hand
- Dirt protection for height adjustment device



S.FL.C

| Item designation | Item no. | VPA1 Pcs/type | VPA2 Pcs/type | VPA3 Pcs/type |
|-------------------|----------|------------------|------------------|------------------|
| K.FL.C-DS.BR | 5081107 | 100 BL | 300 KK | 7200 EK |
| K.FL.C-DS.BZ-OPL | 5081113 | 100 BL | 300 KK | 7200 EK |
| K.FL.C-DS.BZ-RB | 5081112 | 100 BL | 300 KK | 7200 EK |
| K.FL.C-DS.CW | 5081110 | 100 BL | 300 KK | 7200 EK |
| K.FL.C-DS.F1 | 5081114 | 100 BL | 300 KK | 7200 EK |
| K.FL.C-DS.F1-ELOX | 5081115 | 100 BL | 300 KK | 7200 EK |
| K.FL.C-DS.F1-OPL | 5081116 | 100 BL | 300 KK | 7200 EK |
| K.FL.C-DS.F3 | 5081117 | 100 BL | 300 KK | 7200 EK |
| K.FL.C-DS.F3-MG | 5081118 | 100 BL | 300 KK | 7200 EK |
| K.FL.C-DS.F9 | 5081108 | 100 BL | 300 KK | 7200 EK |
| K.FL.C-DS.SW | 5081111 | 100 BL | 300 KK | 7200 EK |
| K.FL.C-DS.UN77078 | 5081119 | 100 BL | 300 KK | 7200 EK |
| K.FL.C-DS.WS | 5081106 | 100 BL | 300 KK | 7200 EK |
| S.FL.C.BR | 5065609 | 500 BL | 3000 KK | 24000 EK |
| S.FL.C.CW | 5065675 | 500 BL | 3000 KK | 24000 EK |
| S.FL.C.F1 | 5065610 | 500 BL | 3000 KK | 24000 EK |
| S.FL.C.F9 | 5065611 | 500 BL | 3000 KK | 24000 EK |
| S.FL.C.WS | 5065612 | 500 BL | 3000 KK | 24000 EK |

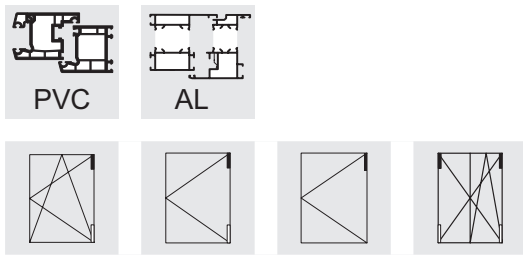

Shear hinge SL.C

- Rolled steel hinge
- Fixing screws are covered by the shear hinge insert.
- Integrated pin-securing device
- Remove shear pin by means of special pulling device
- A small free size of the frame is required.
- For drilling instructions see group 15, installation drawings

Shear hinge cover K.SL.C-DS

- See separate product page

Additional plate ZSP.SL. C

- Positioning and screwing above the shear hinge SL.C
- Improves the load transfer of the shear hinge to the frame by increasing the number of screws
- Enables higher traction values acc. to TBDK (e.g. in case of steelless systems)
- Available in different colours
- Covers K.SL.C... cannot be used in this combination.

SL.C

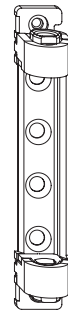

K.SL.C-DS

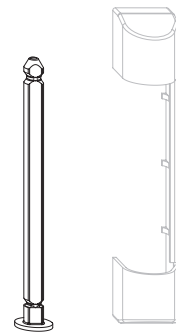

ZSP.SL.C



SL.C

| Item designation | Item no. |  | Max. sash weight (kg) | VPA1 Pcs/type | VPA2 Pcs/type | VPA3 Pcs/type |
|------------------|----------|---|-----------------------|------------------|------------------|------------------|
| SL.C.3-3 | 5081484 | 4 | 80 | 200 KK | 1600 EK | |
| SL.C.3-3.BR | 5081487 | 4 | 80 | 200 KK | 1600 EK | |
| SL.C.3-3.CW | 5081488 | 4 | 80 | 200 KK | 1600 EK | |
| SL.C.3-3.F9 | 5081486 | 4 | 80 | 200 KK | 1600 EK | |
| SL.C.3-3.WS | 5081485 | 4 | 80 | 200 KK | 1600 EK | |
| SL.C.3-6 | 5081489 | 4 | 130/150 | 200 KK | 1600 EK | |
| SL.C.3-6.BR | 5081492 | 4 | 130/150 | 200 KK | 1600 EK | |
| SL.C.3-6.CW | 5081493 | 4 | 130/150 | 200 KK | 1600 EK | |
| SL.C.3-6.F9 | 5081491 | 4 | 130/150 | 200 KK | 1600 EK | |
| SL.C.3-6.WS | 5081490 | 4 | 130/150 | 200 KK | 1600 EK | |
| ZSP.SL.C.WS | 5086827 | 1 | | 100 BL | 2000 KK | 16000 EK |
| ZSP.SL.C.F9 | 5086828 | 1 | | 100 BL | 2000 KK | 16000 EK |
| ZSP.SL.C.CW | 5086829 | 1 | | 100 BL | 2000 KK | 16000 EK |

WS = white, BR = brown, SL = silver, EV1 = anodised silver, F1 = silver colour, F3 = gold colour, BZ-RB = bronze red brown, F9 = titanium coloured, CW = cream white

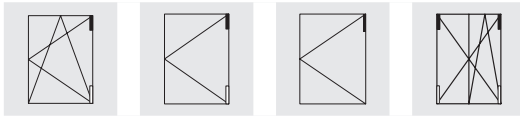
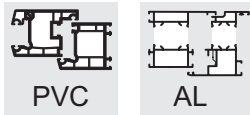

Caps

Shear hinge cover K.SL.C-DS

- Cover for shear hinge SL.C
- Can be used left and right hand

Shear hinge cap K.SK

- Can be used left and right hand
- Available in different colours

K.SL.C-DS



K.SK

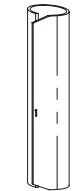

7

| Item designation | Item no. | VPA1 Pcs/type | VPA2 Pcs/type | VPA3 Pcs/type |
|-------------------|----------|------------------|------------------|------------------|
| K.SL.C-DS.BR | 5081091 | 100 BL | 300 KK | 7200 EK |
| K.SL.C-DS.BZ-OPL | 5081099 | 100 BL | 300 KK | 7200 EK |
| K.SL.C-DS.BZ-RB | 5081098 | 100 BL | 300 KK | 7200 EK |
| K.SL.C-DS.CW | 5081096 | 100 BL | 300 KK | 7200 EK |
| K.SL.C-DS.F1 | 5081100 | 100 BL | 300 KK | 7200 EK |
| K.SL.C-DS.F1-ELOX | 5081101 | 100 BL | 300 KK | 7200 EK |
| K.SL.C-DS.F1-OPL | 5081102 | 100 BL | 300 KK | 7200 EK |
| K.SL.C-DS.F3 | 5081103 | 100 BL | 300 KK | 7200 EK |
| K.SL.C-DS.F3-MG | 5081104 | 100 BL | 300 KK | 7200 EK |
| K.SL.C-DS.F9 | 5081092 | 100 BL | 300 KK | 7200 EK |
| K.SL.C-DS.SW | 5081097 | 100 BL | 300 KK | 7200 EK |
| K.SL.C-DS.UN77078 | 5081105 | 100 BL | 300 KK | 7200 EK |
| K.SL.C-DS.WS | 5081090 | 100 BL | 300 KK | 7200 EK |
| K.SK.BR | 4927421 | 100 BL | 600 KK | 14400 EK |
| K.SK.BZ-CN | 5031480 | 100 BL | 300 KK | 2400 EK |
| K.SK.BZ-RB | 4933296 | 100 BL | 600 KK | 4800 EK |
| K.SK.CW | 4927572 | 100 BL | 600 KK | 4800 EK |
| K.SK.F1 | 4928484 | 100 BL | 600 KK | 4800 EK |
| K.SK.F1-ELOX. | 5021124 | 100 BL | 600 K3 | 4800 E3 |
| K.SK.F3 | 4995009 | 100 BL | 600 KK | 4800 EK |
| K.SK.F3 BA | 5034998 | 100 BL | 600 KK | 4800 EK |
| K.SK.F3-MG | 4987480 | 100 BL | 600 KK | 4800 EK |
| K.SK.F9 | 2845293 | 100 BL | 600 KK | 14400 EK |
| K.SK.LBR | 4939036 | 100 BL | 600 KK | 4800 EK |
| K.SK.SL.UN77078 | 4993489 | 100 BL | 600 KK | 4800 EK |
| K.SK.SW | 4939055 | 100 BL | 600 KK | 4800 EK |
| K.SK.WS | 2845285 | 100 BL | 600 KK | 14400 EK |

AGR = anthracite grey, BR = brown, BZ-AM = bronze - antique brass, BZ-RB = bronze - red brown, BZ-CU = bronze coppery, CW = cream white, EV1 = anodised silver, F1 = silver colour, F1-elox = sim. to F1 anodised silver, F3 = gold colour, F3-MG = gold mat, F9 = titanium-coloured, LBR = clay brown, PW = pearl white, SG = silver grey, SGB = grey, SGR = dust grey, SL = silver look (galvanised), SW = deep black, WS = white

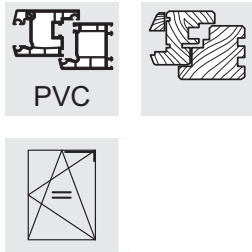

Shears SC ... PA.20-13

- Suitable for top rods OS1.PA / OS2.PA
- Adjustment for lifting and lowering the sash (+3.5/-2.0 mm)
- Tilt opening width approx. 135 to 140 mm (depending on profile)
- After assembly the top rod and the shear are firmly attached to one another
- Integrated turn restriction via plastic sleeve in shear hinge
- Sash weight max. 100 kg
- With integrated control curve
- Operating sequence: locked - tilt position - parallel action - turn position

Shear hinge cap K.SK

- Can be used left and right hand

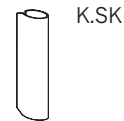
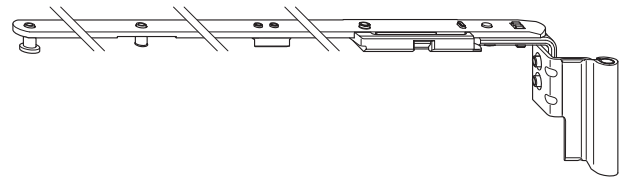
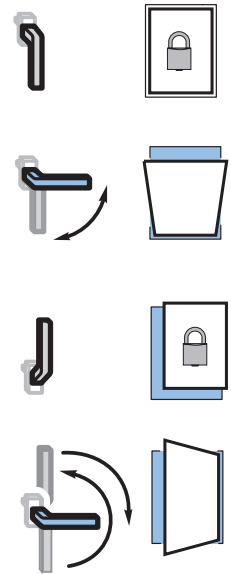

| Item designation | Item no. | Overlap | Groove centre position | VPA1 Pcs/type | VPA2 Pcs/type | VPA3 Pcs/type |
|--------------------|----------|---------|------------------------|---------------|---------------|---------------|
| SC1.PA.20-13.LS.F9 | 5067559 | 20 | 13 | 10 BD | 60 KK | 1440 EK |
| SC1.PA.20-13.RS.F9 | 5067557 | 20 | 13 | 10 BD | 60 KK | 1440 EK |
| SC1.PA.20-13.LS.SL | 5067554 | 20 | 13 | 10 BD | 60 KK | 1440 EK |
| SC1.PA.20-13.RS.SL | 5067553 | 20 | 13 | 10 BD | 60 KK | 1440 EK |
| SC1.PA.20-13.LS.WS | 5067556 | 20 | 13 | 10 BD | 60 KK | 1440 EK |
| SC1.PA.20-13.RS.WS | 5067555 | 20 | 13 | 10 BD | 60 KK | 1440 EK |
| SC2.PA.20-13.LS.F9 | 5067566 | 20 | 13 | 10 BD | 80 GK | 960 EK |
| SC2.PA.20-13.RS.F9 | 5067565 | 20 | 13 | 10 BD | 80 GK | 960 EK |
| SC2.PA.20-13.LS.SL | 5067561 | 20 | 13 | 10 BD | 80 GK | 960 EK |
| SC2.PA.20-13.RS.SL | 5067560 | 20 | 13 | 10 BD | 80 GK | 960 EK |
| SC2.PA.20-13.LS.WS | 5067564 | 20 | 13 | 10 BD | 80 GK | 960 EK |
| SC2.PA.20-13.RS.WS | 5067562 | 20 | 13 | 10 BD | 80 GK | 960 EK |

RS = right, LS = left
 WS = white, BR = brown, SL = silver, F1 = silver coloured, F3 = gold coloured, F9 = titanium coloured

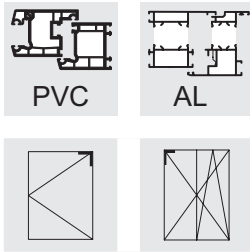

Turn hinge insert DL.C

- Used in combination with shear hinge SL.C
- Available for mounting left and right hand
- Integrated turn restriction via plastic sleeve in shear hinge
- Visible parts available in various colours
- Adjustment for lifting and lowering the sash (+3/-2 mm)
- Pressure adjustment ± 0.8 mm
- Used with turn hinge bracket DLW.ERW
- Max. sash weight 130/150 kg

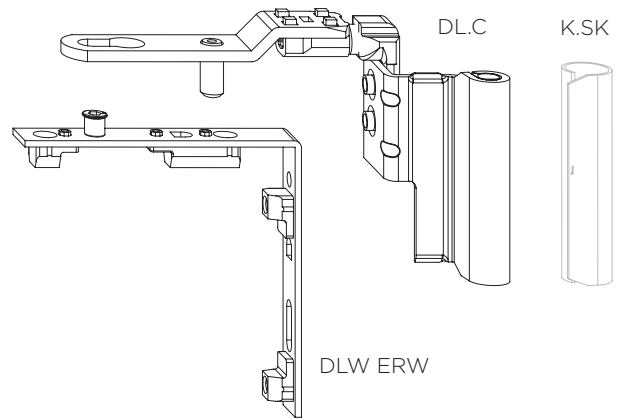

8

Turn hinge bracket DLW.ERW

- Used to hold the turn hinge insert
- Automatic and manual assembly possible
- Faceplate width 16 mm
- Can be used left and right hand

Shear hinge cap K.SK

- See separate product page

| Item designation | Item no. | Groove centre position | Overlap | VPA1 Pcs/type | VPA2 Pcs/type |
|------------------|----------|------------------------|---------|---------------|---------------|
| DL.C.20-13.LS | 5063154 | 13 | 20 | 100 KK | 800 EK |
| DL.C.20-13.RS | 5063153 | 13 | 20 | 100 KK | 800 EK |
| DL.C.20-13.LS.BR | 5063160 | 13 | 20 | 100 KK | 800 EK |
| DL.C.20-13.RS.BR | 5063159 | 13 | 20 | 100 KK | 800 EK |
| DL.C.20-13.LS.F9 | 5063158 | 13 | 20 | 100 KK | 800 EK |
| DL.C.20-13.RS.F9 | 5063157 | 13 | 20 | 100 KK | 800 EK |
| DL.C.20-13.LS.WS | 5063156 | 13 | 20 | 100 KK | 800 EK |
| DL.C.20-13.RS.WS | 5063155 | 13 | 20 | 100 KK | 800 EK |
| DL.C.20-13.PLS | 5063162 | 13 | 20 | 100 KK | 800 EK |
| DL.C.20-13.PRS | 5063161 | 13 | 20 | 100 KK | 800 EK |

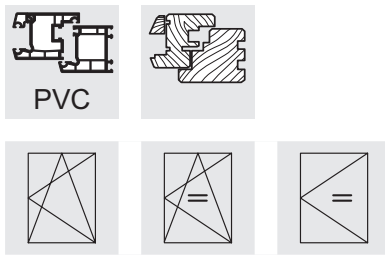

Interlocking rod MK.PA. ...

- Clampable in fitting groove

Coupling element KE

- Application area:
combination of two geared elements, such as an FL.E.FW-PA sash hinge and an MK interlocking rod
- Cutting area 250 mm
- Component length 510 mm

Interlocking rod M

- Central fastening loosens automatically by tightening fitting screw
- Functional both vertically and horizontally

Interlocking rod MK

- Extendable interlocking rod, can be combined with Winkhaus standard gearing
- Otherwise this design is identical to interlocking rod M

MK.PA...



KE



M...



MK...



| Item designation | Item no. |  | VPA1 Pcs/type | VPA2 Pcs/type | VPA3 Pcs/type |
|------------------|----------|---|------------------|------------------|------------------|
| MK.PA.250-1 | 4965415 | 3 | 20 BD | 100 KK | 800 EK |
| KE SL | 4982891 | 1 | 10 BD | 1000 EA | |
| M.250-1 | 2822471 | 2 | 20 BD | 100 KK | 800 EK |
| M.500-1 | 4933994 | 3 | 20 BD | 100 GK | 1200 EK |
| M.500-1.C | 4933999 | 3 | 20 BD | 100 GK | 1200 EK |
| M.750-1 | 4940652 | 5 | 20 BD | 500 EA | |
| MK.250-0 | 4929185 | 2 | 20 BD | 100 KK | 800 EK |
| MK.250-1 | 2824919 | 2 | 20 BD | 100 KK | 800 EK |
| MK.500-0 | 4929187 | 3 | 20 BD | 500 EA | |
| MK.500-0.C | 4932315 | 3 | 20 BD | 500 EA | |
| MK.500-1 | 2824986 | 3 | 20 BD | 500 EA | |
| MK.500-1.C | 4932287 | 3 | 20 BD | 500 EA | |
| MK.750-1 | 4940653 | 5 | 20 BD | 500 EA | |

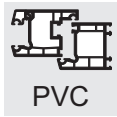

PVC



AL

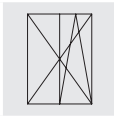
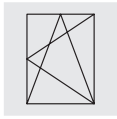
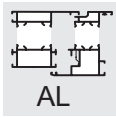

Extension rod V.AK.450-1

- Used to position a locking point near the sash hinge (up to RC2 / RC2 N / SKG**)
- Functional both vertically and horizontally
- Not extendable
- Clampable in fitting groove
- Component length 450 mm
- Cutting area 250 mm

9

Extension rod VK.AK.450-1

- Same construction as described above, but it can be connected to Winkhaus standard gearing

Extension rod V.AK.450-1.BS16

- The components specially developed for threshold solutions (sash and frame side) can be gathered from the catalogue "Complementary range activPilot threshold components..."

V.AK.450-1

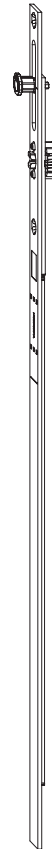

VK.AK.450-1



| Item designation | Item no. |  | VPA1 Pcs/type | VPA2 Pcs/type | VPA3 Pcs/type |
|------------------|----------|---|------------------|------------------|------------------|
| V.AK.450-1 | 4942706 | 3 | 10 BD | 1000 EA | |
| VK.AK.450-1 | 5071694 | 2 | 20 BD | 100 GK | 400 EK |

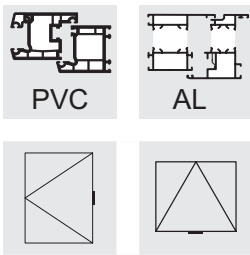

Claw bolt ZV-FT SL

- Central locking device for turn-only windows
- Assembly on the sash
- Concealed in the rebate
- Adjustable for airgaps of 11 to 14 mm
- In combination with ZV-RT SL frame parts

Keep ZV-RT SL

- Central locking device for turn-only windows
- Installation on the frame
- Concealed in the rebate
- For airgaps of 11 to 14 mm
- Profile attribution see keep overview

ZV-FT

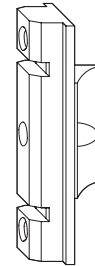

ZV-RT



| Item designation | Item no. |  | Groove centre position | VPA1 Pcs/type | VPA2 Pcs/type | VPA3 Pcs/type |
|------------------|----------|---|------------------------|---------------|---------------|---------------|
| ZV-FT SL | 2359324 | 2 | 9/13 | 10 BL | 100 KK | 800 EK |

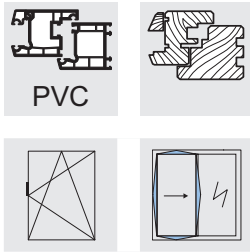

Fail safe device FSF

- Prevents the operation of the handle while the window is open
- An actuation of the fitting system is only possible as soon as the fail-safe device integrated in the sash touches the frame.
- No separate frame part required
- Suitable for groove positions from 9 to 13 mm
- Suitable for retrofit installation into drive rods GAK and GAM
- Can be used left and right hand
- Pressure piece adjustment ± 2 mm

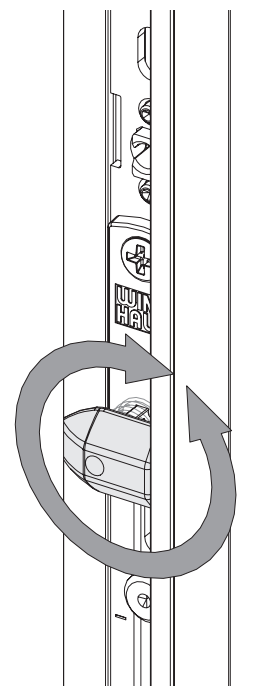
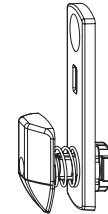

Fail-safe device FSF.C

- Version as described above, but clippable for fixation in the face plate

Important to know:

- The component's delivery state is neutral with regard to the DIN direction!
- After installation the tip of the pressure piece must be directed towards the frame!
- For airgaps smaller or larger than 12 mm an adjustment is possible by turning the plastic part to the left or to the right!

10

| Item designation | Item no. |  | Groove centre position | VPA1 Pcs/type | VPA2 Pcs/type | VPA3 Pcs/type |
|------------------|----------|---|------------------------|---------------|---------------|---------------|
| FSF | 5031156 | 1 | 9/13 | 100 BL | 500 KK | 4000 EK |
| FSF.13 | 5055737 | 1 | 13 | 100 BL | 500 KK | 4000 EK |
| FSF.13.C | 5066280 | 1 | 13 | 100 BL | 500 KK | 4000 EK |

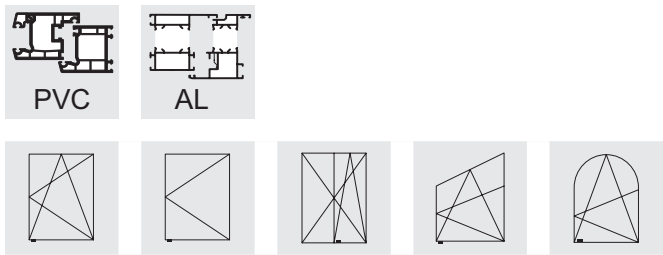

Keep on sash side

- For lifting the sash during closing

Support plate AL.M.F12

- For assembly in the suitable holes of the extension rod or for direct fitting in the sash-side fitting groove
- Installation height 11.5 mm
- Colour: anthracite grey or dusty grey

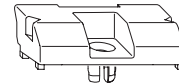

AL.M.F12

Support plate AL FR BN 13/12 FC SL

- Direct fitting in the eurogroove
- Installation height 11.5 mm
- Colour: silver

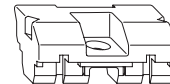

AL FR BN.../
AL.BN.F12

Support plate AL.BN.F12

- Direct fitting in the eurogroove
- Suitable for use on screwdriving units
- Installation height 11.5 mm
- Colour: anthracite grey

Support plate AL.E.F

- Is fixed to the corner drive on the sash side if no interlocking rod is used
- Suitable for use on screwdriving units
- Installation height 11.5 mm
- Colour: anthracite grey
- Not suitable for activPilot Comfort / duoPort PAS

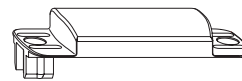

AL.E.F

Keep GRT.AL.F

- The components specially developed for threshold solutions (sash and frame side) can be gathered from the catalogue "Complementary range activPilot threshold components...".

| Item designation | Item no. |  | VPA1 Pcs/type | VPA2 Pcs/type | VPA3 Pcs/type |
|----------------------|----------|---|------------------|------------------|------------------|
| AL.M.F12.AGR | 4927494 | 1 | 100 BL | 400 KK | 9600 EK |
| AL.M.F12.SGR | 5008456 | 1 | 100 BL | 400 KK | 9600 EK |
| AL FR BN 13/12 FC SL | 2295640 | 1 | 100 BL | 400 KK | 3200 EK |
| AL.BN.F12 | 4927493 | 1 | 100 BL | 400 KK | 9600 EK |
| AL.E.F | 4933076 | 1 | 200 KK | 1600 EK | |

AGR = anthracite grey, SGR = dust grey

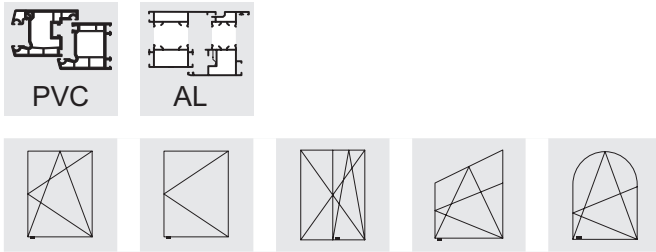

Keep, on the frame

- For lifting the sash during closing

Support plate AL D

- Installation in frame.
- Can be used for different profile systems thanks to adapter FT.WSK...
- Installation height 11 mm
- Colour: anthracite grey or white

AL D

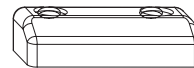

Support plate AL D 10 WS

- Installation in frame.
- Can be used for different profile systems thanks to adapter FT.WSK...
- Installation height 10 mm
- Colour white

10

Keep AL K.SBS.W

- Mounted into security keep SBS...
- Colour: dust grey similar to RAL 7037

AL K.SBS.W

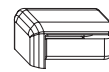

SBS...

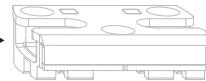

Threshold keep AL.SBK...BS

- The components specially developed for threshold solutions (sash and frame side) can be gathered from the catalogue "Complementary range activPilot threshold components..."

| Item designation | Item no. |  | VPA1 Pcs/type | VPA2 Pcs/type | VPA3 Pcs/type |
|------------------|----------|---|------------------|------------------|------------------|
| AL D AGR | 4969481 | 2 | 100 BL | 400 KK | 3200 EK |
| AL D WS | 1475542 | 2 | 100 BL | 400 KK | 3200 EK |
| AL D 10 WS | 2091583 | 2 | 100 BL | 400 KK | 3200 EK |
| AL K.SBS.W | 4978509 | 0 | 100 BL | 1000 KK | 8000 EK |

AGR = anthracite grey, WS = white

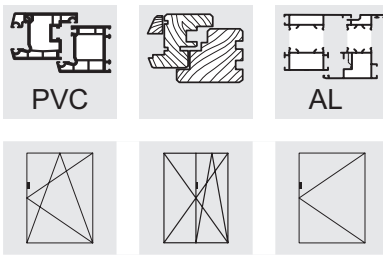

Drilling protection AB.G.D

- Protects the housing of drive units against being drilled open from the outside in line with DIN EN 1627-1630
- Can be used left and right hand
- Material: Steel 1 mm thick, hardened

Drilling protection AB.G.D.15.5

- Backset 15.5 mm

Drilling protection AB.G.D.7.5

- Backset 7.5 mm



AB.G.D.15,5

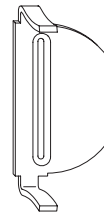

AB.G.D.7,5

| Item designation | Item no. | VPA1 Pcs/type | VPA2 Pcs/type | VPA3 Pcs/type |
|------------------|----------|------------------|------------------|------------------|
| AB.G.D.15,5 | 4939745 | 100 BL | 1000 KK | 8000 EK |
| AB.G.D.7,5 | 4939747 | 50 BL | 250 KK | 2000 EK |

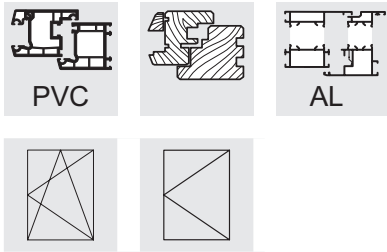

Connection rod VS R SL

- Used to connect two long parts with interlocking action

End plate ASP ER-A SL

- Serves as an end profile on corner drives or extensible interlocking rods to cover the connecting rod / the gearing

End plate ASP ER-A.F

- Design as described above, but clampable

Connecting plate SP.R SL

- For connecting a corner drive with a component that needs shortening, e.g. a drive rod or top rod
- Use only in case of repair, as a positive and non-positive fit is no longer guaranteed
- The element to be shortened can be cut straight

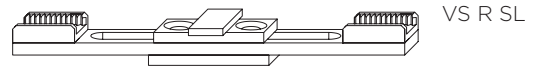

VS R SL

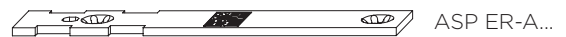

ASP ER-A...



SP R SL

| Item designation | Item no. |  | VPA1 Pcs/type | VPA2 Pcs/type | VPA3 Pcs/type |
|------------------|----------|---|------------------|------------------|------------------|
| VS R SL | 1882172 | 2 | 20 BL | 100 KK | 800 EK |
| ASPE.A.125 | 5074503 | 2 | 500 KK | 4000 EK | |
| ASPE.A.F.125 | 5074504 | 2 | 500 KK | 4000 EK | |
| SP.R SL | 1934201 | 1 | 100 BL | 1000 KK | 8000 EK |

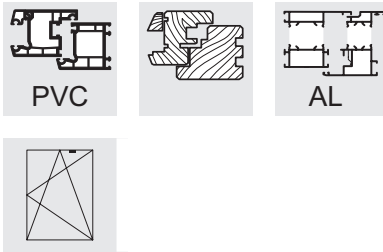

Accessories Top Rod OS

Anti-slam device ZSS.OS

- Can be used left and right hand
- Prevents tilted windows slamming shut in case of light draughts and low window sashes

- ZSS.OS1 for top rod OS1. ...
- ZSS.OS2 for top rod OS2. ...

Tilt limiter KBG.OS

- Can be used left and right hand
- Reduces tilt opening width by approx. 50 mm
- Recommended for use with sash heights below 600 mm

- KBG.OS1 for top rod OS1. ...
- KBG.OS2 for top rod OS2. ...

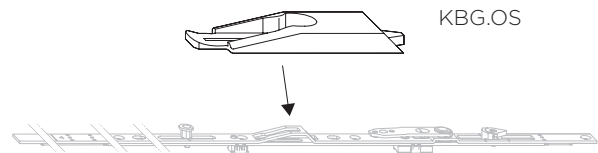
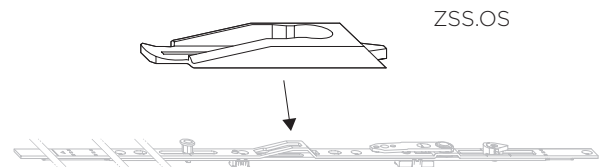

| Item designation | Item no. |  | VPA1 Pcs/type | VPA2 Pcs/type | VPA3 Pcs/type |
|------------------|----------|---|------------------|------------------|------------------|
| ZSS.OS1 | 4936654 | 0 | 100 BL | 1000 KK | 8000 EK |
| ZSS.OS2 | 4936655 | 0 | 100 BL | 1000 KK | 8000 EK |
| KBG.OS1.SW | 5053676 | 0 | 100 BL | 1000 KK | 8000 EK |
| KBG.OS2 | 5053677 | 0 | 100 BL | 1000 KK | 8000 EK |

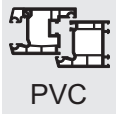

PVC



Neutral frame parts (milled version)

- Serves as routing variant for order-specific profile adjustment: without adjustment it cannot be used.

Tilt Keep SBK...PA

- Installation position at the bottom right or left towards the drive side
- With tilt/turn control slider
- For holding the adjusting/tilt bolt
- The SBK.K. keep can be positioned without needing a jig.
- Number of screws: 4

Security Keep SBS...PAB

- Number of screws: 4

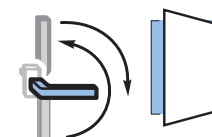
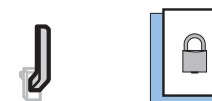
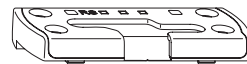
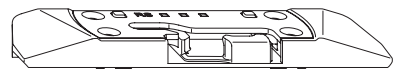

| Item designation | Item no. |  | VPA1 Pcs/type | VPA2 Pcs/type |
|------------------|----------|---|------------------|------------------|
| SBK.K.PA.1.RS | 4968647 | 4 | 50 KK | 400 EK |
| SBK.K.PA.1.LS | 4968648 | 4 | 50 KK | 400 EK |
| SBS.K.PAB.1.RS | 4966472 | 4 | 50 KK | 400 EK |
| SBS.K.PAB.1.LS | 4966473 | 4 | 50 KK | 400 EK |

RS = right, LS = left

activPilot Comfort

Print no. 996 000 850 / 03/2023

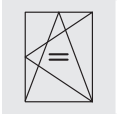
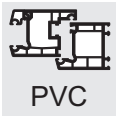

Frame parts

- Profile dependent see Group 11, Frame Parts

Tilt Keep SBK...PA

- Installation position at the bottom right or left towards the drive side
- With tilt/turn control slider
- For holding the adjusting/tilt bolt
- The SBK.K. keep can be positioned without needing a jig.
- Number of screws: 4

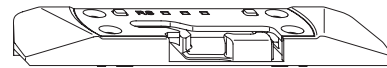

Security Keep SBS...PAB

- Number of screws: 4

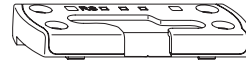

Keep SBAK

- Profile dependent
- Can be used left and right hand

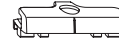

Spacer FT WSK

- Profile dependent
- Can be used left and right hand

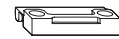

Keep ZV-RT SL

- Central locking device for turn-only windows
- Installation on the frame
- Concealed in the rebate
- For airgaps of 11 to 14 mm
- Profile dependent

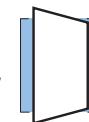
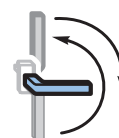
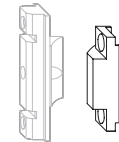

activPilot Comfort







Print no. 996 000 850 / 03/2023

Aluplast

Ideal 4000 - 8000, Energeto, Energeto Neo

NML 13 mm

UEB 20 mm







| SBK.PA  | | SBS.PAB  | | SBS.PAD  | | SBA  | |
|--|---------|---|---------|--|---------|---|---------|
| SBK.K.PA.161.LS | 4989277 | SBS.K.PAB.161.LS | 4989275 | SBS.K.PAD.161.LS | 4995615 | SBA.K.161 | 2824071 |
| SBK.K.PA.161.RS | 4989276 | SBS.K.PAB.161.P10.LS | 5097271 | SBS.K.PAD.161.P10.LS | 5097273 | SBA.K.161.S.40 | 5001559 |
| | | SBS.K.PAB.161.P10.RS | 5097270 | SBS.K.PAD.161.P10.RS | 5097272 | SBA.K.66 | 4932001 |
| | | SBS.K.PAB.161.RS | 4989274 | SBS.K.PAD.161.RS | 4995614 | | |
| ZV  | | FT  | | FH  | | | |
| ZV-RT 161 RC SL | 1213945 | FT WSK 66 | 1530185 | FH.161 | 4949431 | | |
| | | | | FH.R.161 | 4995855 | | |

Brüggmann / Salamander

System AD

NML 13 mm

UEB 20 mm







| SBK.PA  | | SBS.PAB  | | SBS.PAD  | | SBA  | |
|--|---------|---|---------|--|---------|---|---------|
| SBK.K.PA.94.LS | 5005495 | SBS.K.PAB.94.LS | 5005499 | | | SBA.K.94.P7 | 4927716 |
| SBK.K.PA.94.RS | 5005496 | SBS.K.PAB.94.RS | 5005940 | | | | |
| ZV  | | FT  | | FH  | | | |
| ZV-RT 452/13 SL | 2074732 | FT WSK152 | 1787079 | FH.152 | 4949428 | | |
| | | | | FH.R.152 | 4995853 | | |
| | | | | FH.R.152.M10 | 5011126 | | |

Brüggmann / Salamander

System MD

NML 13 mm

UEB 20 mm







| SBK.PA  | | SBS.PAB  | | SBS.PAD  | | SBA  | |
|--|---------|---|---------|--|---------|---|---------|
| SBK.K.PA.94.LS | 5005495 | SBS.K.PAB.94.LS | 5005499 | | | SBA.K.94.P7 | 4927716 |
| SBK.K.PA.94.RS | 5005496 | SBS.K.PAB.94.RS | 5005940 | | | | |
| ZV  | | FT  | | FH  | | | |
| ZV-RT 452/13 SL | 2074732 | FT WSK152 | 1787079 | FH.152 | 4949428 | | |
| | | | | FH.R.152 | 4995853 | | |
| | | | | FH.R.152.M10 | 5011126 | | |

Deceuninck

Arcade, Prestige, Deluxe, Elite, MD100, Eforte

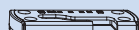
NML 13 mm

UEB 21 mm







| SBK.PA  | | SBS.PAB  | | SBS.PAD  | | SBA  | |
|--|---------|---|---------|--|---------|---|---------|
| SBK.K.PA.192.LS | 4984402 | SBS.K.PAB.192.LS | 4984400 | SBS.K.PAD.192.LS | 4995623 | SBA.K.192 | 5002139 |
| SBK.K.PA.192.RS | 4984401 | SBS.K.PAB.192.RS | 4984289 | SBS.K.PAD.192.RS | 4995622 | SBA.K.192.RWS | 4932786 |
| | | | | | | SBA.K.192.S12 | 4939192 |
| ZV  | | FT  | | FH  | | | |
| ZV-RT 192 RC SL | 1261395 | FT WSK 192 | 1330722 | FH.192 | 4949434 | | |
| | | | | FH.L.192 | 5008876 | | |
| | | | | FH.R.192 | 4995858 | | |

Deceuninck

iCOR, Elegant







NML 13 mm

UEB 21 mm

| SBK.PA  | | SBS.PAB  | | SBS.PAD  | | SBA  | |
|--|---------|---|---------|--|---------|---|---------|
| SBK.K.PA.169.LS | 4989301 | SBS.K.PAB.169.LS | 4989289 | SBS.K.PAD.169.LS | 4995621 | SBA.K.169 | 5073712 |
| SBK.K.PA.169.RS | 4989300 | SBS.K.PAB.169.RS | 4989288 | SBS.K.PAD.169.RS | 4995620 | SBA.K.169_0,7 | 5073713 |
| ZV  | | FT  | | FH  | | | |
| ZV-RT 169 RC SL | 5033656 | FT WSK169 | 2356596 | FH.205 | 4949429 | | |
| | | | | FH.L.205 | 5002710 | | |
| | | | | FH.R.205 | 4995854 | | |







**Deceuninck
Zendow, Neo**

**NML 13 mm
UEB 20 mm**

| SBK.PA  | | SBS.PAB  | | SBS.PAD  | | SBA  | |
|---|---------|--|---------|--|---------|--|---------|
| SBK.K.PA.169.LS | 4989301 | SBS.K.PAB.169.LS | 4989289 | SBS.K.PAD.169.LS | 4995621 | SBA.K.169 | 5073712 |
| SBK.K.PA.169.RS | 4989300 | SBS.K.PAB.169.RS | 4989288 | SBS.K.PAD.169.RS | 4995620 | SBA.K.169_0,7 | 5073713 |
| ZV  | | FT  | | FH  | | | |
| ZV-RT 169 RC SL | 5033656 | FT WSK169 | 2356596 | FH.205 | 4949429 | | |
| | | | | FH.L.205 | 5002710 | | |
| | | | | FH.R.205 | 4995854 | | |







**Gealan
6000, 7000, 8000, 9000**

**NML 13 mm
UEB 20 mm**

| SBK.PA  | | SBS.PAB  | | SBS.PAD  | | SBA  | |
|---|---------|--|---------|--|---------|--|---------|
| SBK.K.PA.162.LS | 4989283 | SBS.K.PAB.162.LS | 4989281 | SBS.K.PAD.162.LS | 4995617 | SBA.K.162 | 4929796 |
| SBK.K.PA.162.RS | 4989282 | SBS.K.PAB.162.RS | 4989280 | SBS.K.PAD.162.RS | 4995616 | | |
| ZV  | | FT  | | FH  | | | |
| ZV-RT 162 SL | 2088350 | FT WSK 62 | 1348121 | FH.205 | 4949429 | | |
| ZV-RT 62 SL | 2094258 | | | FH.L.205 | 5002710 | | |
| | | | | FH.R.205 | 4995854 | | |







**KBE (Profine)
70 AD / 70 MD / 88+**

**NML 13 mm
UEB 20 mm**

| SBK.PA  | | SBS.PAB  | | SBS.PAD  | | SBA  | |
|---|---------|--|---------|--|---------|--|---------|
| SBK.K.PA.205.LS | 4989307 | SBS.K.PAB.205.LS | 5053598 | SBS.K.PAD.205.LS | 4995625 | SBA.K.205.P5 | 2922210 |
| SBK.K.PA.205.RS | 4989306 | SBS.K.PAB.205.RS | 5053597 | SBS.K.PAD.205.RS | 4995624 | | |
| ZV  | | FT  | | FH  | | | |
| ZV-RT 169 RC SL | 5033656 | FT WSK205 | 1809590 | FH.205 | 4949429 | | |
| | | | | FH.L.205 | 5002710 | | |
| | | | | FH.R.205 | 4995854 | | |







**KBE (Profine)
76 AD, 76 MD**

**NML 13 mm
UEB 20 mm**

| SBK.PA  | | SBS.PAB  | | SBS.PAD  | | SBA  | |
|---|---------|--|---------|--|---------|--|---------|
| SBK.K.PA.205.LS | 4989307 | SBS.K.PAB.205.LS | 5053598 | SBS.K.PAD.205.LS | 4995625 | SBA.K.205.P5 | 2922210 |
| SBK.K.PA.205.RS | 4989306 | SBS.K.PAB.205.RS | 5053597 | SBS.K.PAD.205.RS | 4995624 | | |
| ZV  | | FT  | | FH  | | | |
| ZV-RT 169 RC SL | 5033656 | FT WSK205 | 1809590 | FH.205 | 4949429 | | |
| | | | | FH.L.205 | 5002710 | | |
| | | | | FH.R.205 | 4995854 | | |

**Kömmerling (Profine)
76 AD, 76 MD**

**NML 13 mm
UEB 20 mm**







| SBK.PA  | | SBS.PAB  | | SBS.PAD  | | SBA  | |
|---|---------|--|---------|--|---------|--|---------|
| SBK.K.PA.205.LS | 4989307 | SBS.K.PAB.205.LS | 5053598 | SBS.K.PAD.205.LS | 4995625 | SBA.K.205.P5 | 2922210 |
| SBK.K.PA.205.RS | 4989306 | SBS.K.PAB.205.RS | 5053597 | SBS.K.PAD.205.RS | 4995624 | | |
| ZV  | | FT  | | FH  | | | |
| ZV-RT 169 RC SL | 5033656 | FT WSK205 | 1809590 | FH.205 | 4949429 | | |
| | | | | FH.L.205 | 5002710 | | |
| | | | | FH.R.205 | 4995854 | | |

Kömmerling (Profine)

Classic, Elegance, Avantgarde, 88+

NML 13 mm

UEB 20 mm







| SBK.PA  | | SBS.PAB  | | SBS.PAD  | | SBA  | |
|--|---------|---|---------|--|---------|---|---------|
| SBK.K.PA.144.LS | 4989265 | SBS.K.PAB.144.LS | 4989263 | SBS.K.PAD.144.LS | 4995609 | SBA.K.144 | 2920652 |
| SBK.K.PA.144.RS | 4989264 | SBS.K.PAB.144.RS | 4989262 | SBS.K.PAD.144.RS | 4995608 | SBA.K.144.V | 4927431 |
| | | | | | | SBA.K.244 | 4931453 |
| ZV  | | FT  | | FH  | | | |
| ZV-RT 144 SL14 | 2020081 | FT WSK144 | 1326221 | FH.144 | 4949433 | | |
| | | | | FH.R.144 | 4995856 | | |

Rehau

Geneo, Synego

NML 13 mm

UEB 20 mm







| SBK.PA  | | SBS.PAB  | | SBS.PAD  | | SBA  | |
|--|---------|---|---------|--|---------|---|---------|
| SBK.K.PA.160.LS | 4968642 | SBS.K.PAB.160.LS | 4966467 | SBS.K.PAD.160.LS | 4995613 | SBA.K.160 | 4933116 |
| SBK.K.PA.160.RS | 4968641 | SBS.K.PAB.160.RS | 4966466 | SBS.K.PAD.160.RS | 4995612 | | |
| ZV  | | FT  | | FH  | | | |
| ZV-RT 160 | 4933117 | FT WSK 60 | 1345393 | FH.205 | 4949429 | | |
| | | | | FH.L.205 | 5002710 | | |
| | | | | FH.R.205 | 4995854 | | |

Rehau

S735, Brillant, Thermo-Design, Brillant-Design, Basic-Design

NML 13 mm

UEB 20 mm







| SBK.PA  | | SBS.PAB  | | SBS.PAD  | | SBA  | |
|--|---------|---|---------|--|---------|---|---------|
| SBK.K.PA.60.LS | 4989253 | SBS.K.PAB.60.LS | 4989251 | SBS.K.PAD.UG.60.LS | 5017314 | SBA.K.60 | 2824046 |
| SBK.K.PA.60.RS | 4989252 | SBS.K.PAB.60.RS | 4989250 | SBS.K.PAD.UG.60.RS | 5017313 | SBA.K.60 -0,3 | 4931375 |
| ZV  | | FT  | | FH  | | | |
| ZV-RT 60 SL | 1975336 | FT WSK 60 | 1345393 | FH.60 | 4949432 | | |
| | | | | FH.R.60 | 4995857 | | |

Salamander

2D / 3D / MD / Streamline

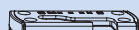
NML 13 mm

UEB 20 mm







| SBK.PA  | | SBS.PAB  | | SBS.PAD  | | SBA  | |
|--|---------|---|---------|--|---------|---|---------|
| SBK.K.PA.28.LS | 4968646 | SBS.K.PAB.28.LS | 4966471 | SBS.K.PAD.28.LS | 4995601 | SBA.K.28 | 4926452 |
| SBK.K.PA.28.RS | 4968645 | SBS.K.PAB.28.RS | 4966470 | SBS.K.PAD.28.RS | 4995600 | SBA.K.28.P5 | 5059941 |
| ZV  | | FT  | | FH  | | | |
| ZV-RT 134 SL | 2864478 | FT WSK134 | 1537651 | FH.144 | 4949433 | | |
| | | | | FH.R.144 | 4995856 | | |

Salamander

bluEvolution 82







NML 13 mm

UEB 20 mm

| SBK.PA  | | SBS.PAB  | | SBS.PAD  | | SBA  | |
|--|---------|---|---------|--|---------|---|---------|
| SBK.K.PA.94.LS | 5005495 | SBS.K.PAB.94.LS | 5005499 | | | SBA.K.94.P7 | 4927716 |
| SBK.K.PA.94.RS | 5005496 | SBS.K.PAB.94.RS | 5005940 | | | | |
| ZV  | | FT  | | FH  | | | |
| ZV-RT 134 SL | 2864478 | FT WSK134 | 1537651 | FH.152 | 4949428 | | |
| | | | | FH.R.152 | 4995853 | | |
| | | | | FH.R.152.M10 | 5011126 | | |

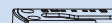





**Salamander
bluEvolution 92**

NML 13 mm
UEB 20 mm

| SBK.PA  | | SBS.PAB  | | SBS.PAD  | | SBA  | |
|--|---------|---|---------|---|---------|---|---------|
| SBK.K.PA.128.W.LS | 4984408 | SBS.K.PAB.128.W.LS | 4984406 | SBS.K.PAD.128.LS | 4995607 | SBA.K.28 | 4926452 |
| SBK.K.PA.128.W.RS | 4984407 | SBS.K.PAB.128.W.RS | 4984405 | SBS.K.PAD.128.RS | 4995606 | SBA.K.28.P5 | 5059941 |
| ZV  | | FT  | | FH  | | | |
| ZV-RT 134 SL | 2864478 | FT WSK134 | 1537651 | FH.205 | 4949429 | | |
| | | | | FH.L.205 | 5002710 | | |
| | | | | FH.R.205 | 4995854 | | |







**Salamander
greenEvolution**

NML 13 mm
UEB 20 mm

| SBK.PA  | | SBS.PAB  | | SBS.PAD  | | SBA  | |
|--|---------|---|---------|---|---------|---|---------|
| SBK.K.PA.94.LS | 5005495 | SBS.K.PAB.94.LS | 5005499 | | | SBA.K.94.P7 | 4927716 |
| SBK.K.PA.94.RS | 5005496 | SBS.K.PAB.94.RS | 5005940 | | | | |
| ZV  | | FT  | | FH  | | | |
| ZV-RT 134 SL | 2864478 | FT WSK134 | 1537651 | FH.152 | 4949428 | | |
| | | | | FH.R.152 | 4995853 | | |
| | | | | FH.R.152.M10 | 5011126 | | |







**Schüco
Corona 70 / Corona SI 82**

NML 13 mm
UEB 20 mm

| SBK.PA  | | SBS.PAB  | | SBS.PAD  | | SBA  | |
|--|---------|---|---------|---|---------|---|---------|
| SBK.K.PA.166.LS | 4978144 | SBS.K.PAB.166.LS | 4978140 | SBS.K.PAD.166.LS | 4995619 | SBA.K.166 | 4930272 |
| SBK.K.PA.166.RS | 4978143 | SBS.K.PAB.166.RS | 4978119 | SBS.K.PAD.166.RS | 4995618 | | |
| ZV  | | FT  | | FH  | | | |
| ZV-RT 60 SL | 1975336 | FT WSK 61 | 1497653 | FH.152 | 4949428 | | |
| | | | | FH.R.152 | 4995853 | | |
| | | | | FH.R.152.M10 | 5011126 | | |







**Schüco
Living**

NML 13 mm
UEB 20 mm

| SBK.PA  | | SBS.PAB  | | SBS.PAD  | | SBA  | |
|--|---------|---|---------|---|---------|---|---------|
| SBK.K.PA.166.LS | 4978144 | SBS.K.PAB.166.LS | 4978140 | SBS.K.PAD.166.LS | 4995619 | SBA.K.166 | 4930272 |
| SBK.K.PA.166.RS | 4978143 | SBS.K.PAB.166.RS | 4978119 | SBS.K.PAD.166.RS | 4995618 | | |
| ZV  | | FT  | | FH  | | | |
| ZV-RT 60 SL | 1975336 | FT WSK 61 | 1497653 | FH.152 | 4949428 | | |
| | | | | FH.R.152 | 4995853 | | |
| | | | | FH.R.152.M10 | 5011126 | | |







**Trocal (Profine)
76 AD, 76 MD**

NML 13 mm
UEB 20 mm

| SBK.PA  | | SBS.PAB  | | SBS.PAD  | | SBA  | |
|--|---------|---|---------|---|---------|---|---------|
| SBK.K.PA.205.LS | 4989307 | SBS.K.PAB.205.LS | 5053598 | SBS.K.PAD.205.LS | 4995625 | SBA.K.205.P5 | 2922210 |
| SBK.K.PA.205.RS | 4989306 | SBS.K.PAB.205.RS | 5053597 | SBS.K.PAD.205.RS | 4995624 | | |
| ZV  | | FT  | | FH  | | | |
| ZV-RT 169 RC SL | 5033656 | FT WSK205 | 1809590 | FH.205 | 4949429 | | |
| | | | | FH.L.205 | 5002710 | | |
| | | | | FH.R.205 | 4995854 | | |

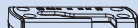





Trocal (Profine)
InnoNova 2000 / 88+

NML 13 mm
UEB 20 mm

| SBK.PA  | | SBS.PAB  | | SBS.PAD  | | SBA  | |
|---|---------|--|---------|---|--|--|---------|
| SBK.K.PA.126.LS | 4989259 | SBS.K.PAB.126.LS | 4989257 | | | SBA.K.126 | 4926196 |
| | | SBS.K.PAB.126.RS | 4989256 | | | | |
| ZV  | | FT  | | FH  | | | |
| ZV-RT 226 RC SL | 2389494 | FT WSK 42 | 1320680 | | | | |

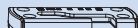





Trocal (Profine)
InnoNova A5 / M5

NML 13 mm
UEB 20 mm

| SBK.PA  | | SBS.PAB  | | SBS.PAD  | | SBA  | |
|---|---------|--|---------|---|---------|--|---------|
| SBK.K.PA.226.LS | 4968644 | SBS.K.PAB.226.LS | 4966469 | SBS.K.PAD.226.RS | 4995626 | SBA.K.226 | 2921090 |
| SBK.K.PA.226.RS | 4968643 | | | | | | |
| ZV  | | FT  | | FH  | | | |
| | | FT WSK226 | 2304155 | FH.152 | 4949428 | | |
| | | | | FH.R.152 | 4995853 | | |
| | | | | FH.R.152.M10 | 5011126 | | |

Veka
Softline 70 AD/MD, Softline 82 AD/MD, Softline 76 AD/MD, Artline 82

NML 13 mm
UEB 20 mm

| SBK.PA  | | SBS.PAB  | | SBS.PAD  | | SBA  | |
|---|---------|--|---------|---|---------|--|---------|
| SBK.K.PA.152.LS | 4989271 | SBS.K.PAB.152.LS | 4989269 | SBS.K.PAD.152.LS | 4995611 | SBA.K.152 | 5050727 |
| SBK.K.PA.152.RS | 4989270 | SBS.K.PAB.152.RS | 4989268 | SBS.K.PAD.152.RS | 4995610 | SBA.K.152_0,5 | 5050726 |
| | | | | | | SBA.K.552_0,5 | 5050725 |
| ZV  | | FT  | | FH  | | | |
| ZV-RT 452/13 SL | 2074732 | FT WSK152 | 1787079 | FH.152 | 4949428 | | |
| | | | | FH.R.152 | 4995853 | | |
| | | | | FH.R.152.M10 | 5011126 | | |

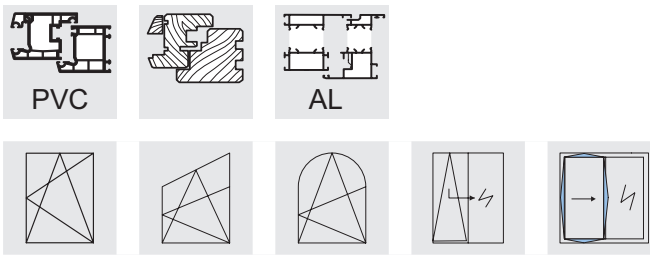

Punches for window fittings

Punch BST AP/FS

- Used to cut fitting elements
- Punch including footswitch
- Pedal operated
- Can be used together with fitting ruler
- Required operating pressure 6 bar

Ruler LIN AP/FS

- Dimensional positioning of the fitting elements to be cut
- Cutting of both central and constant parts

Fitting punch, lever AP.HH

- Used to cut fitting elements
- Manual operation
- Serves as repair punch - not suitable for permanent use

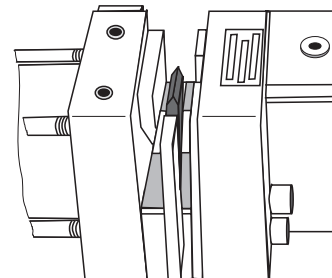

BST AP/FS

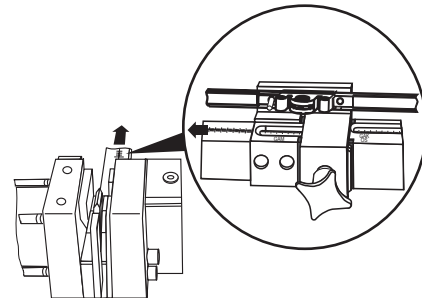

LIN AP/FS

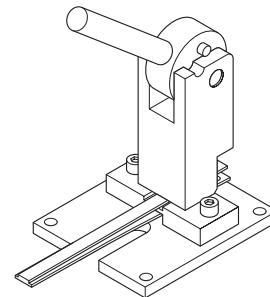

AP.HH

| Item designation | Item no. |
|------------------|----------|
| BST AP/FS LS | 1466339 |
| LIN AP/FS LS | 1466321 |
| AP.HH | 4970430 |

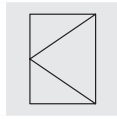
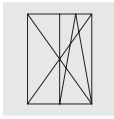
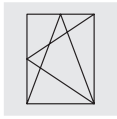
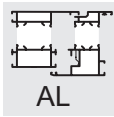
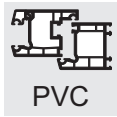

Drill jig LE.B.EL-SL.K

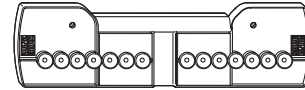

Drilling jig to drill the pilot holes for corner and shear hinges

- Overlap dimension adjustable from 18 to 22 mm
- Preadjusted to a defined dimension
- For hinges with 6 mm pin

LE.B.EL-SL.K.3-3

- For hinges with 3 mm pin

| Item designation | Item no. | Overlap |
|----------------------|----------|---------|
| LE.B.EL-SL.K-18 | 4966329 | 18 |
| LE.B.EL-SL.K-20 | 4966340 | 20 |
| LE.B.EL-SL.K-21 | 4966341 | 21 |
| LE.B.EL-SL.K-22 | 4966342 | 22 |
| LE.B.EL.SL.K. 3-3-18 | 4966343 | 18 |
| LE.B.EL.SL.K. 3-3-20 | 4966345 | 20 |
| LE.B.EL.SL.K. 3-3-21 | 4966346 | 21 |
| LE.B.EL.SL.K. 3-3-22 | 4966347 | 22 |

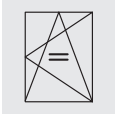
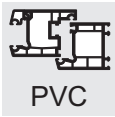

Jig PADK

- Jig for positioning security keeps SBS.K.PAB

Jig LE.N.PADK

- Used for positioning SBS.K.PAB keeps in the frame rebate of the corner area
- Can be used left and right hand

Jig LE.N.SBS.K

- Used for positioning SBS.K.PAB keeps in the frame rebate (except the corner areas)
- Can be used left and right hand

LE.N.PADK

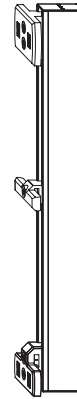

LE.N.K.SBS.K



| Item designation | Item no. | VPA1 Pcs/type | VPA2 Pcs/type |
|-------------------------------|----------|------------------|------------------|
| LE.N.PADK | 4969653 | 25 KK | 200 EK |
| LE.N.K.SBS.K.PAD.RC2.BD | 5004340 | 25 EA | |
| LE.N.K.SBS.K.PAD.RC2.OB.UN | 5004341 | 25 EA | |
| LE.N.K.SBS.K.PAD.RC2.UN | 5004342 | 25 EA | |
| LE.N.K.SBS.K.PAD.RC2.GTR.BD.1 | 5004343 | 25 EA | |
| LE.N.K.SBS.K.PAD.RC2.GTR.BD.2 | 5004344 | 25 EA | |
| LE.N.K.SBS.K.PAD.RC2.GTR.BD.3 | 5004345 | 25 EA | |
| LE.N.K.SBS.K.PAD.RC2.GTR.BD.4 | 5004346 | 25 L1 | |
| LE.N.K.SBS.K.PAD.RC2.GTR.BD.5 | 5004347 | 25 L1 | |
| LE.N.K.SBS.K.PAD.RC2.GTR.BD.6 | 5004348 | 25 L2 | |

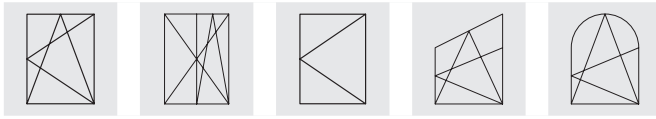
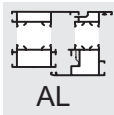
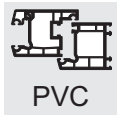

Jigs

- Used to position keeps in frame rebate
- Can be used left and right hand
- How to use please see mounting instructions

Different models:

- LE.N.K jig, constant handle position
- LE.N.T jig, central handle position (telescopic jig), locking drive GAM
- LE.N.T.ST jig, central handle position (telescopic jig), double-sash windows
- LE.N.T.GAVM jig, central handle position (telescopic jig) locking drive GAVM

Positioning aid LE.SB.N

- Serves the purpose of positioning the locking keeps within the frame rebate
- Can be used left and right hand
- Especially used for special window shapes (round or sloping head windows)
- How to use please see mounting instructions

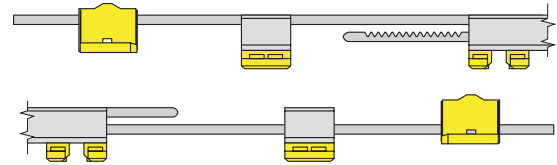

| Item designation | Item no. |
|---------------------|----------|
| LE.N.T.GAVM 300 | 4936773 |
| LE.N.T.GAVM 420 | 4937047 |
| LE.N.T.GAVM 620 | 4937061 |
| LE.N.T.GAVM 920 | 4937063 |
| LE.N.T.GAVM 1320 | 4937064 |
| LE.N.T.GAVM 1850 | 4937065 |
| LE.N.T.ST.0550-1200 | 4926548 |
| LE.N.T.ST.1201-2170 | 4926549 |
| LE.N.K.0290-0709 | 4926540 |
| LE.N.K.0710-1100 | 4926541 |
| LE.N.K.1101-1550 | 4926542 |
| LE.N.K.1551-2225 | 4926543 |
| LE.N.K.2225-4 | 4941065 |
| LE.N.T.0710-1050 | 4926545 |
| LE.N.T.1051-1800 | 4926546 |
| LE.N.T.1801-2300 | 4926547 |
| LE.SB.N | 5039041 |

| | Page | | |
|-----------|--------------------------------------|-----------------|-----------|
| 13 | Installation Instructions | 89 - 117 | 13 |
| 13.1 | Notes on these assembly instructions | | 13.1 |
| 13.2 | Shortening the fittings | | 13.2 |
| 13.3 | Mounting of turn-tilt fittings | | 13.3 |
| 13.6 | Function test / Operation | | 13.6 |

Notes on these assembly instructions

Prerequisites:

The mounting instructions are designed for mounting Winkhaus activPilot fittings for windows and glazed doors only. Fittings are designed for the following sash rebate sizes and sash weights:

- Min. sash rebate width 460 mm
- Max. sash rebate width 1475 mm
- Min. sash rebate height 695 mm
- Max. sash rebate height 2300 mm
- Max. sash size 2.5 m²
- Max. sash weight 100 kg
- Aspect FFB/FFH ≤ 1.5:1
- Airgap 12 mm
- Groove centre position 13 mm
- Frame rebate depth min. 29 mm
- Approved for centre gasket systems and rebate sealing systems with rain guard.



Note: In order to ascertain the permissible sash sizes and sash weights, please refer to the diagrams in the chapter "General Product Information".

Persons involved in mounting fittings must have read and understood this fitting guide. Observe production liability information for all work with fittings. Manufacturer will accept no liability in cases of failure to comply with this guide, deployment of insufficiently qualified staff and unauthorised alterations.

The respective overall fitting must be selected from the original fitting components range. Winkhaus accepts no liability if non-original or unauthorised system accessory parts are used.



Please note! Winkhaus does not provide fastening screws for fitting. Always use fastening screws suitable for the window type and window dimensions.

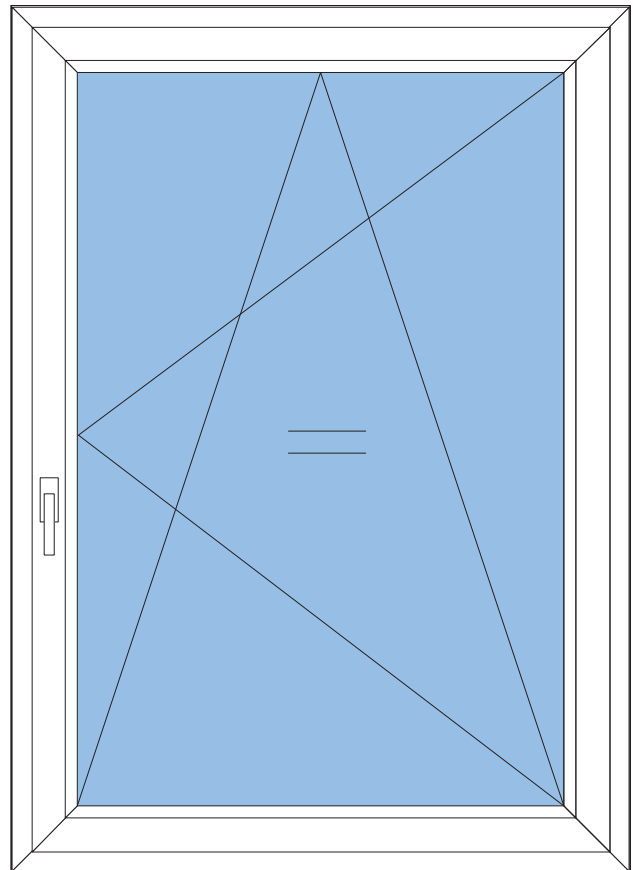



Note: activPilot Comfort fittings are not suitable for use in panic doors! They are not recommended for passage doors.

Standard profile dimensions

See figure: Profile cross-section

The fitting can be used on PVC-U windows with a standard eurogroove.



activPilot Comfort fittings are suitable for centre gasket systems or rebate sealing systems in combination with rain guards.

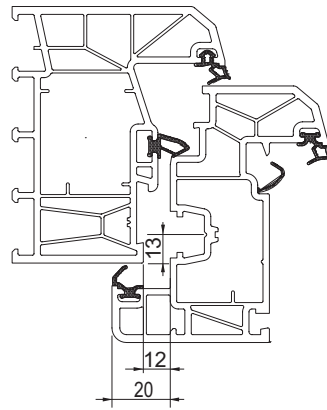

Profile cross-section

Shortening the fittings

A detailed description on shortening of fittings is available here. This description will be referred to in these assembly instructions.

See figure: Fittings prior to punching

- Always insert the face plate (1) and drive rod (2) perpendicularly from the top with the face plate (1) pointing to the pressure cylinder.

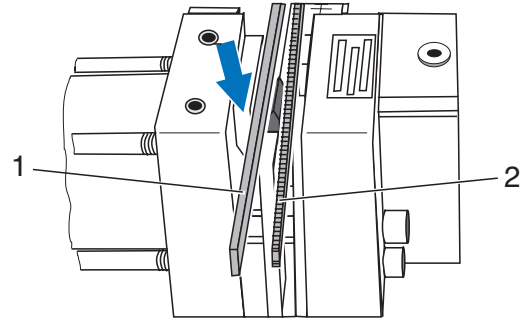

Fittings prior to punching

See figure: Fittings after punching

- After punching, always remove the face plate (1) and drive rod (2) perpendicularly in an upwards direction.

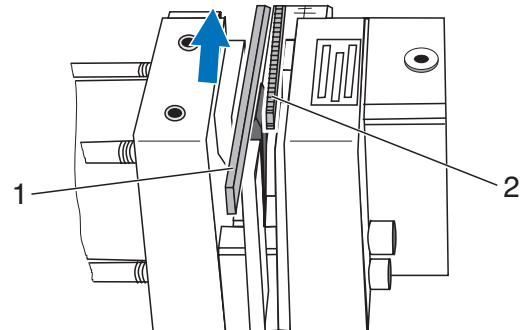

Fittings after punching

See figure: Cleaning the supporting surfaces

- Keep the supporting surfaces (3 and 4) clean.

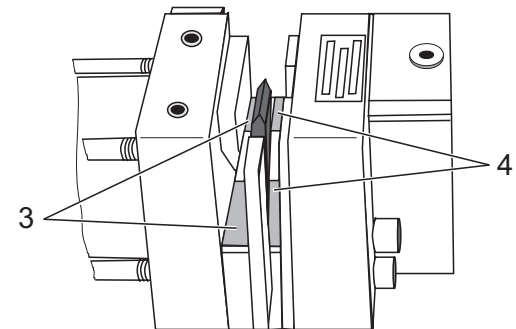

Cleaning the supporting surfaces

13.2

Shorten the drive rod GAM (central handle position)

See figure: Marking GAM

- Set measuring value FFH on the measuring device to the GAM mark.



Please note! If the GAM scale is displaced by one submarking, this corresponds to a longitudinal shift of 2 mm.

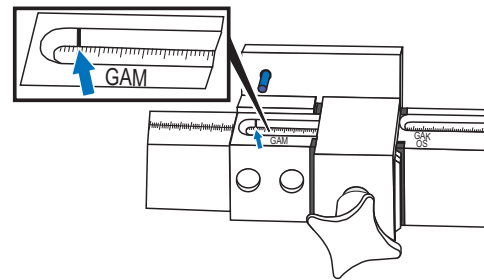

Marking GAM

See figure: Position for shortening drive rod

- Position the GAM drive rod at the scale; slot drill hole (2) onto bolt (1).
- Turn the GAM drive rod around, and slot the drill hole (3) onto the bolt (1), then trim the other side.
- Shorten the drive rod using the fitting punch.

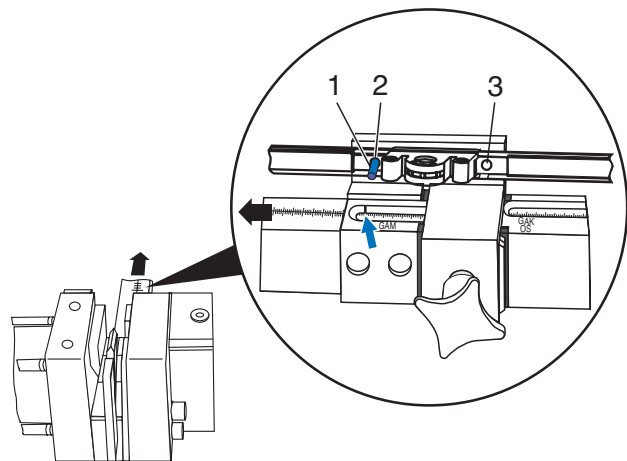

Position for shortening drive rod

Cutting of double sash drive rods GASM

GASM.800

See figure: Cutting instructions GASM

- Adjust the ruler to FFH + 400 mm (example: measured FFH = 567; adjust ruler to 567mm + 400 mm = 967 mm).
- Connect the drive to the marked hole on the ruler (arrows pointing to cutter).
- Cut off the element.

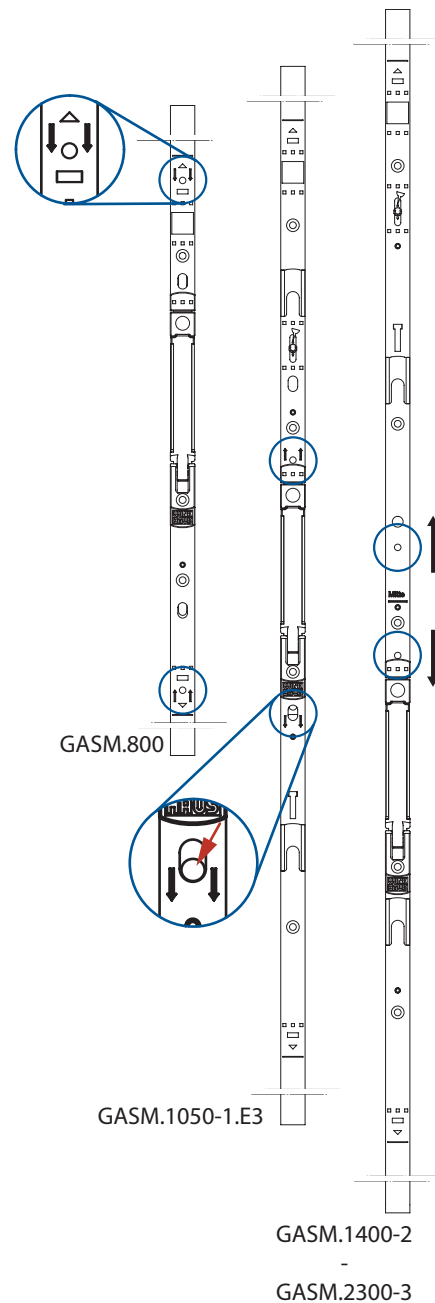

Cutting instructions GASM

GASM.1050 - GASM.2300

See figure: Cutting instructions GASM

- Adjust the ruler to FFH (sash rebate height).
- Connect the drive to the marked hole on the ruler (arrows pointing to cutter).
- In case of GASM.1050 please make sure that the bolt in the elongated hole is positioned as indicated (red arrow).
- Cut off the element.
- GASM.1050 is always used in combination with corner drive E3.



Note: The double-sash drive rod must be trimmed before delivery.

Shorten the GAK / GASK drive rod (constant handle position) and top rod OS



Note: The double-sash drive rod must be trimmed before delivery.

See figure: Markings GAK and OS

- Set the measuring value FFH (GAK/GASK) or FFB (OS) on the measuring device to the GAK/OS mark.



Markings GAK and OS

See figure: Position for shortening drive rod and/or top rod

- Cutting the top rod OS...
 - Position the drive rod GAK/GASK (fixed handle position) (1) or the top rod OS (1) at the bolt (2).
 - Shorten the drive rod (1) or the top rod (1).

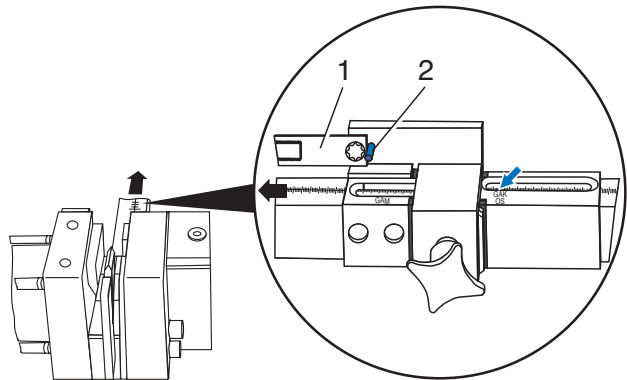

Position for shortening drive rod and/or top rod

Only applies to top rod OS1.600 (OS1.PA.600/OS.XL):

See figure: Position for shortening top rod

- Position the top rod (1) with square holes at bolt (2). At the same time press the offset (see arrow) against the bolt (2).
- Shorten the top rod (1).

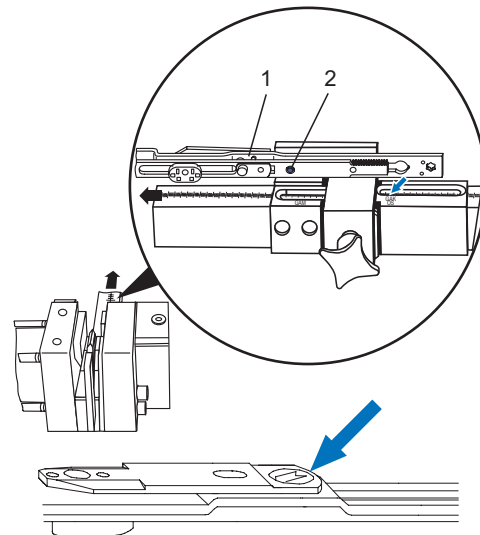

Position for shortening top rod

Mounting of fittings on sash

Turn-tilt type – Rectangular window

Prepare the window for fitting. Then proceed as follows:



Note: The following figures refer to a window for right hand use. When fitting a window for left-hand use, the figures will be mirror-inverted.

The following also applies:

- When viewing the window from the inside, the symbol is depicted as a full line.
- When viewing the window from the outside, the symbol is depicted as a dotted line.

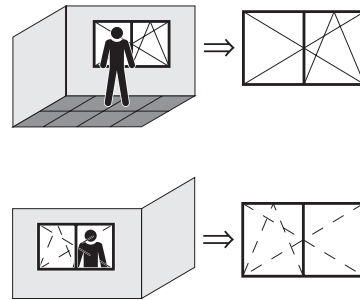

Determine the handle height:

Handle height for drive rod GAM

See figure: Sash rebate height FFH with central handle height GM

If you use a GAM drive rod ... (central handle position), the dimension GM is half the sash rebate height FFH.

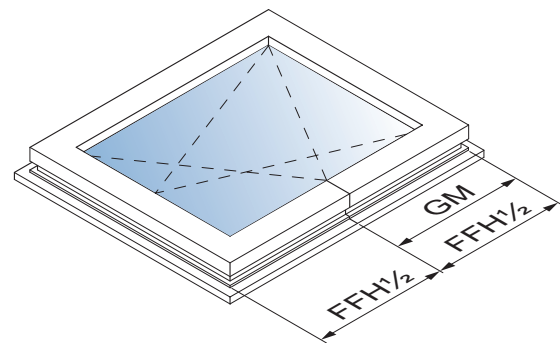

Sash rebate height FFH with central handle height GM

Handle height for drive rod GAK

See figure: Sash rebate height FFH with constant handle position GK

If you use a GAK drive rod ... (constant handle position), dimension GK changes to reflect the sash rebate height FFH. The exact dimensions are specified in the following table.

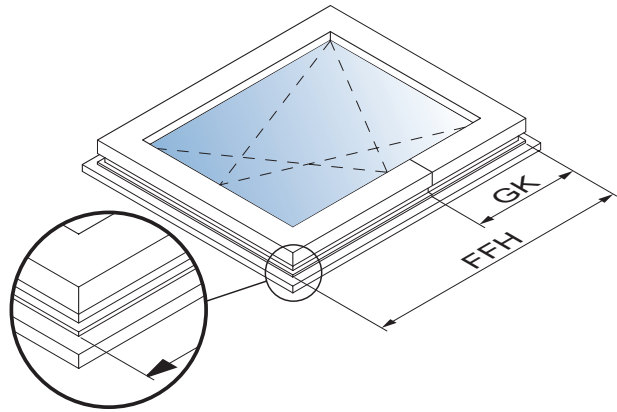

Sash rebate height FFH with constant handle position GK

See figure: Synoptical table: sash rebate height (FFH) / handle position (GK)

The table on the right gives a survey on the handle height (GK) of GAK with regard to the sash rebate height (FFH).

| FFH | GK |
|-------------|------------|
| 230 – 324 | GK = 114 * |
| 325 – 420 | GK = 114 * |
| 421 – 460 | GK = 210 |
| 461 – 700 | GK = 210 |
| 701 – 850 | GK = 260 |
| 851 – 1100 | GK = 375 |
| 1101 – 1325 | GK = 550 |
| 1326 – 1525 | GK = 550 |
| 1526 – 1775 | GK = 550 |
| 1776 – 2000 | GK = 1050 |
| 2001 – 2225 | GK = 1050 |

Synoptical table: sash rebate height (FFH) / handle position (GK)
* Requires the use of E3 corner drive

See figure: Scale drawing "Gear lock"

- Drill holes for gear case (ø 12 mm) as per scale drawing.

Mill the gear housing from the rebate side.

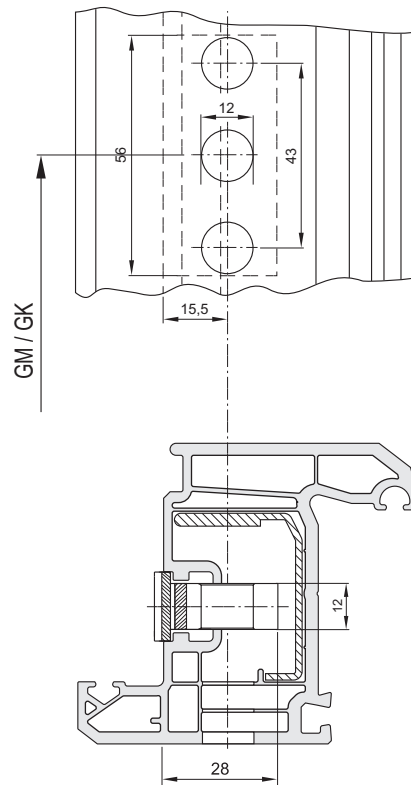

Scale drawing "Gear lock"

See figure: Corner drive E1 / E1.PA

- Fit the corner drive (2) into the fitting groove at the top of the sash so that the octagonal bolt is on the top side.
- Fit the corner drive E1.PA (1) into the fitting groove at the bottom of the sash so that the octagonal bolt is on the drive side.
- Fix both corner drives (1, 2) on the drive side with a single screw each.
- Measure the sash rebate height (FFH).

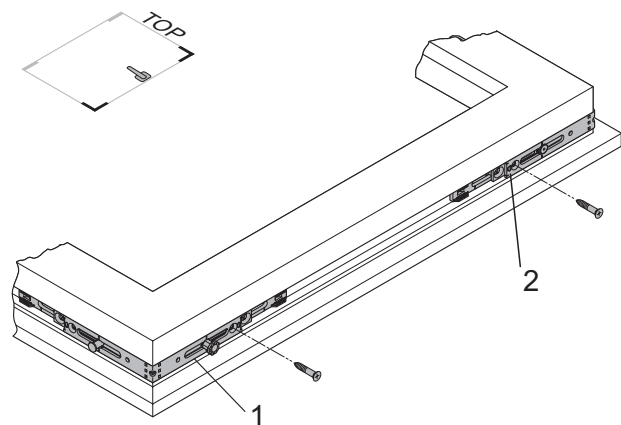

Corner drive E1 / E1.PA

13.3

See figure: Drive rod GAM/GAK

- Cut the drive rod according to the instructions.
- Mount the drive rod:
 - Abut the drive rod (2) flush against the corner drive (3).
 - Allow the teeth on the drive rod to click into position on the gear rack on the corner drive.
 - Clip the drive rod into the corner drive (1) in the same way.
 - Press the drive rod into the eurogroove.
 - Screw the drive rod from the bottom up.



Note: Please make sure that the installation position of the drive rod is correct!

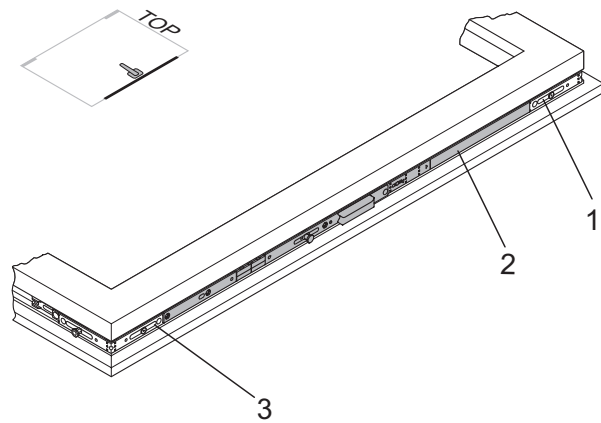

Drive rod GAM/GAK

See figure: Corner drive E2

- Fit the corner drive (1) into the fitting groove at the top of the sash so that the octagonal bolt is on the hinge side.
- Fasten the corner drive on the sash using a screw (2).
- Measure the sash rebate width (FFB).



Note: When the top rod OS1.PA.600 is used, replace the E2 corner drive by E3 corner drive.

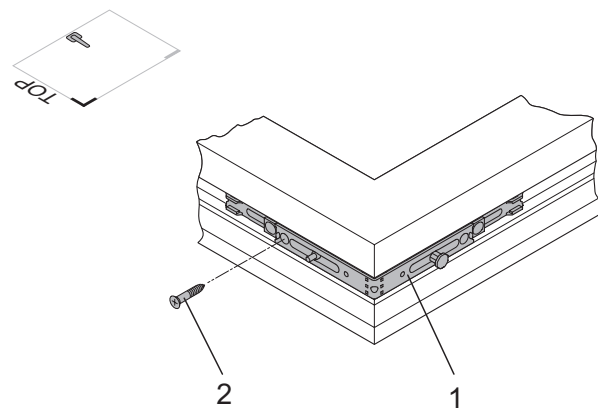

Corner drive E2

- Cut the top rod (see chapter 'Shortening the fittings').



Note: For FFH < approx. 600 mm (depending on profile), place tilt limiter on top rod OS... (2).

See figure: Top rod OS2.PA...

- Insert the top rod and screw into position.
 - Fit the top rod flush against the corner drive (1).
 - Allow the gear teeth to click into place on the rack in the corner drive.
 - Clip the top rod into the corner drive (3) in the same way.
 - Press the top rod into the fitting groove.
 - Screw the top rod from the hinge side to the drive side.

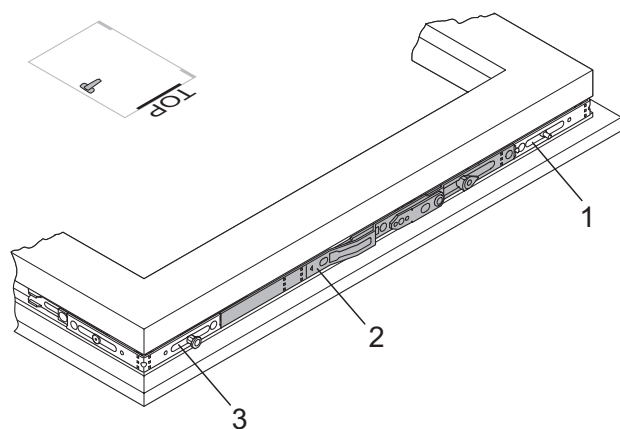

Top rod OS2.PA...

See figure: Shears

- Mounting the shear:
 - Swivel out the hold-up shore (2) (see arrow).
 - Clip shear into the top rod (3) using mushroom bolt (4).
 - Press the shear bolt (5) into the spring on the hold-up shore.
 - Swivel the hold-up shore and shear to home position.
 - Press the shear onto the bolt (1).

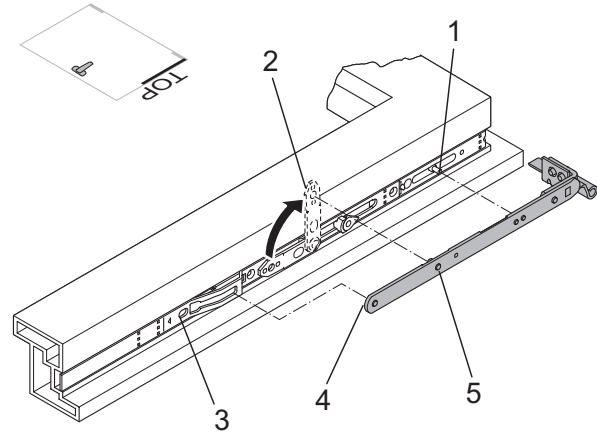

Shears



Please note! Risk of injury. The sash can fall out and cause injuries if the shear and top rod are not securely fastened.



Note: For a sash rebate height (FFH) and/or sash rebate width (FFB) of approx 800 mm (depending on the profile) an interlocking rod should also be fitted hinge-side and/or horizontally at the bottom / top.

See figure: Interlocking rod MK.PA

- Fit the interlocking rod (1) flush against the corner drive (2).
- Click the interlocking rod gears into the teeth of the corner drive.
- Press the interlocking rod into the fitting groove.
- Screw the interlocking rod from the top down.
- Tighten the screw (3) fully to release the central fastening.

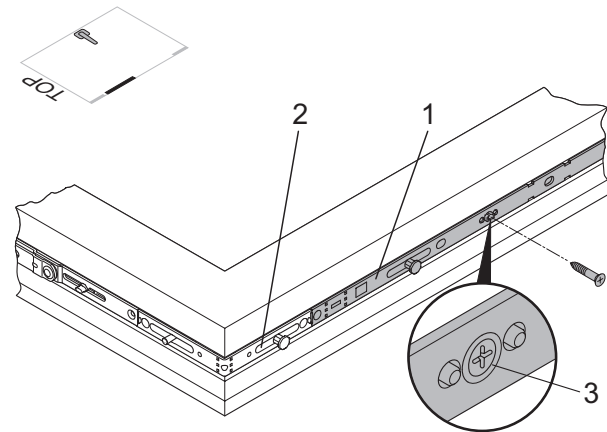

Interlocking rod MK.PA



Please note! Damage to fittings. If the central fastening is not released, the locking device cannot be actuated. Use of force will lead to torsion of the fittings. Always insert the screw fully up to the stop.

13.3

See figure: Sash hinges

- Fitting the sash hinge:
 - Fit the sash hinge into the eurogroove at the bottom of the sash so that the octagonal bolt is on the underside.
 - Fix the sash hinge on the hinge side with 2 screws and on the underside using 1 screw.
 - Measure the sash rebate width (FFB).



Note: Fit the sash hinge in place with \varnothing 3.9 to 4.2 mm screws. Min. screw length 25 mm. Make sure that the sash hinge is entirely flush within the eurogroove.



Important to observe for Trocal 88+ profile system! For Trocal 88+ please remove the centre bar at the frame (bottom hinge side, at level of sash hinge). From frame rebate edge approx. 70 mm to the top!

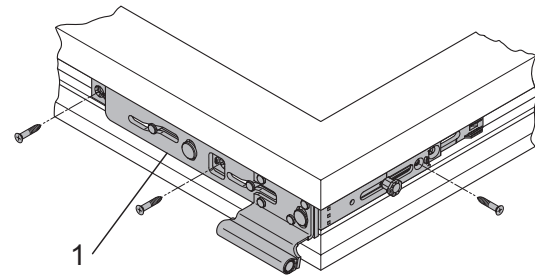
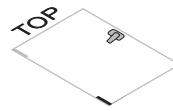

Sash hinges

See figure: Support plate AL.M.F12

- Mount the coupling element, the interlocking rod and the support plate on the underside:
 - Fit the interlocking rod to the corner hinge E1.PA taking the sash rebate width into account.
 - Cut the coupling element to the required dimension.
 - Abut the coupling element against the sash hinge with the side to be cut pointing towards the drive side.
 - Click the coupling element gears into the teeth of the sash hinge.
 - Tighten the screw (3) fully to release the central fastening.
 - Fix the support plate on the coupling element with a screw.
 - Optional: Assembly of sash lifter GRT.FH.H (with lifter and counter plate to protect the frame)

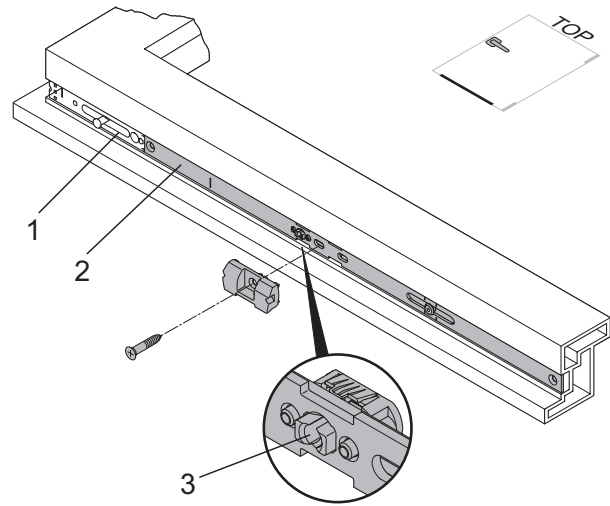

Support plate AL.M.F12

See figure: Fail safe device FSF

- Mount the fail safe device:
 - Insert the fail safe device on the hole pattern of the drive rod and fix with a screw.
 - If required, turn the head by 90° (depends on profile).
 - Mounting a frame part is not necessary.

Important to know:

- The component's delivery state is neutral with regard to the DIN direction!
- After installation the tip of the pressure piece must be directed towards the frame!
- For airgaps smaller or larger than 12 mm an adjustment is possible by turning the plastic part to the left or to the right!

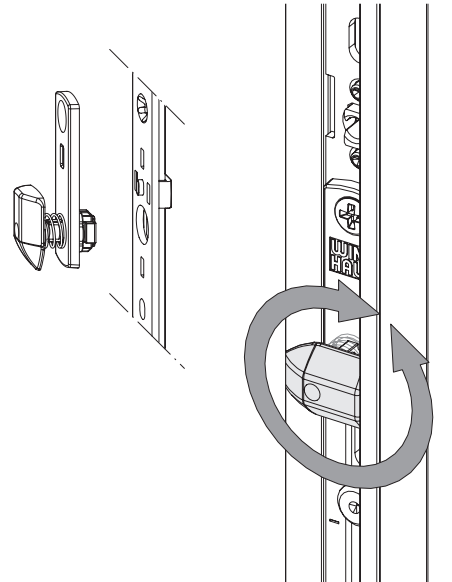

Fail safe device FSF

13.3

 Please note! Check if all screws are fixed into place on the fitting parts.

Turn double sash type – Rectangular window

i Note: The following figures refer to a window for left hand use. When fitting a window for right-hand use, the figures will be mirror-inverted.

See figure: Corner drive E1 (1) / E1.SBS.U (2)

- Fit the corner drive (2) into the fitting groove at the top of the sash so that the octagonal bolt is on the top side.
- Fit the corner drive (1) into the fitting groove at the bottom of the sash so that the octagonal bolt is on the underside.
- Fix both corner drives (1, 2) on the drive side with a single screw each.

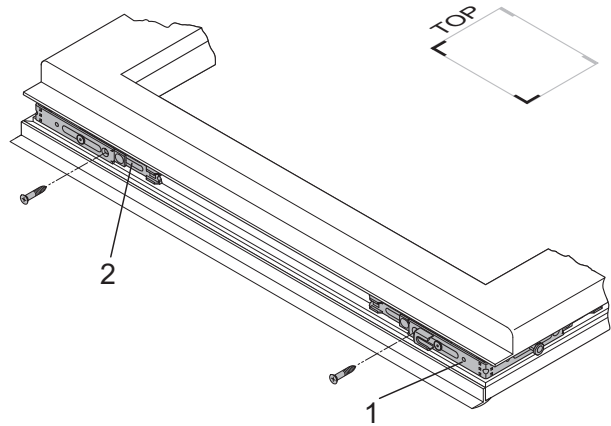

Corner drive E1 (1) / E1.SBS.U (2)

- Shorten the drive rod:
 - Shorten drive rod GASM or drive rod GASK in line with description "Shortening the fittings".

i Note: Make sure you shorten the drive rod in closed state (as delivered).

See figure: Drive rod GASM/GASK

- Mount the drive rod:
 - Abut the drive rod (2) flush against the corner drive (3).
 - Allow the teeth on the drive rod to click into position on the gear rack on the corner drive.
 - Clip the drive rod into the corner drive (1) in the same way.
 - Press the drive rod into the eurogroove.
 - Screw the drive rod from the bottom up.

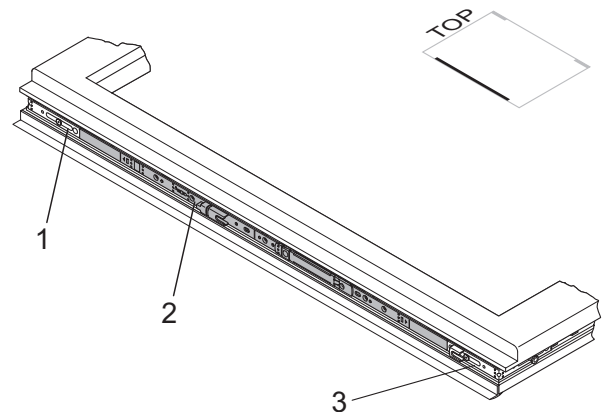

Drive rod GASM/GASK

i Note: to keep a neutral position, do not perform a function test until all fittings are in place.

See figure: Turn hinge bracket/turn hinge

- Mount the turn hinge bracket and turn hinge insert:
 - Fit the turn hinge bracket (1) into the eurogroove at the top of the sash so that the connecting bolt is on the top side.
 - Make sure the turn hinge bracket is flush.
 - Screw the turn hinge bracket onto the sash.
 - Insert the turn hinge insert (2) into the turn hinge bracket (1).

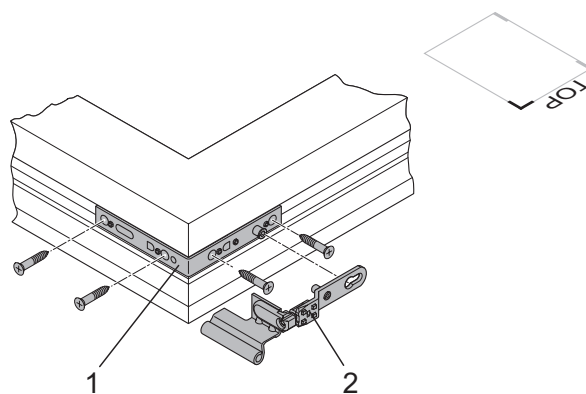

Turn hinge bracket/turn hinge



Note: For a sash rebate height (FFH) and/or sash rebate width (FFB) of approx 800 mm (depending on the profile) an interlocking rod should also be fitted hinge-side and/or horizontally at the bottom / top. Observe the profile system supplier's processing guidelines in this respect.

See figure: Interlocking rod M (top)

- Mount the interlocking rod on the top side:
 - Fit the interlocking rod (1) flush against the corner drive (2).
 - Click the interlocking rod gears into the teeth of the corner drive.
 - Press the interlocking rod into the fitting groove.
 - Screw the interlocking rod tight from the hinge side to the gear side.
 - Tighten the screw (3) fully to release the central fastening.

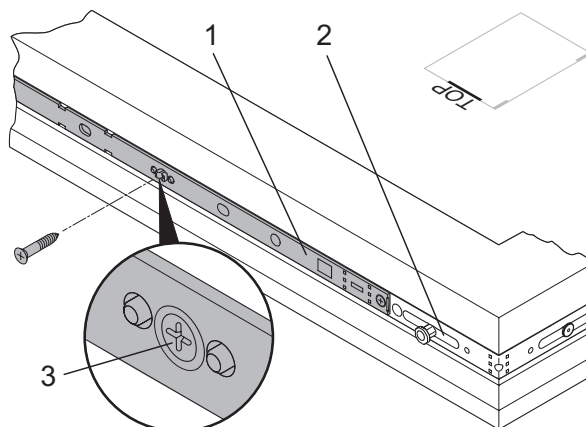

Interlocking rod M (top)



Please note! Damage to fittings. If the central fastening is not released, the locking device cannot be actuated. Use of force will lead to torsion of the fittings. Always insert the screw fully up to the stop.

See figure: Interlocking rod M (bottom)

- Mount interlocking rod on the underside:
- See above

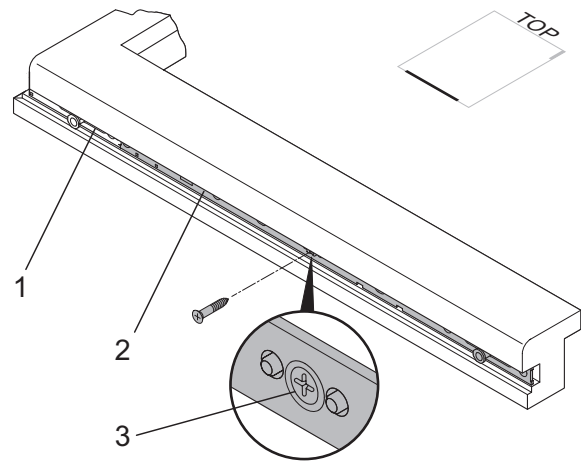

Interlocking rod M (bottom)

See figure: Claw bolt ZV-FT (hinge side)

- Position the claw bolt (1):
- S (ZV-FT) = sash rebate edge to centre of keep ZV-FT
- Press the claw bolt into the eurogroove and screw in place.

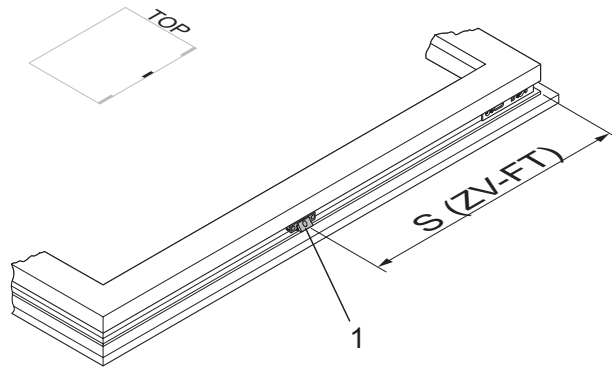

Claw bolt ZV-FT (hinge side)

See figure: Sash hinges

- Fitting the sash hinge:
- Position the mounting jig (1), clamp into the fitting groove and drill \varnothing 6 mm holes for the hinge plugs.
- Drill \varnothing 3 mm holes for screws through the first wall.
- Insert the sash hinge (2) and fix it in place. Min. screw length 35 mm.
- Make sure the sash hinge is fitted correctly into position.

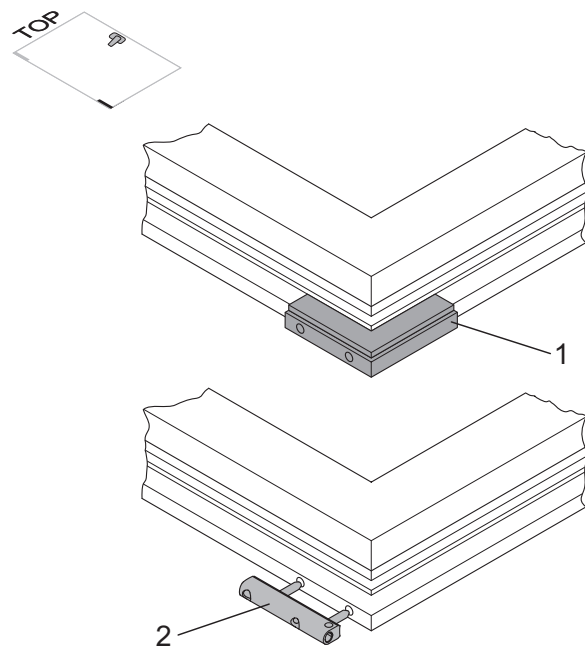

Sash hinges

Mounting of fittings on the window frame

Turn-tilt sash and turn double sash – Rectangular window

See figure: Holes for corner and shear hinges

- Pre-drill the holes for shear and corner hinges and positions of the pins with \varnothing 6 mm.
- Use the template (1) to drill holes for corner hinge (3) and shear hinge (2). Distance between drill holes for shear and corner hinges is the same.



Note: Do not fit the shear and corner hinges until after fitting the keeps.

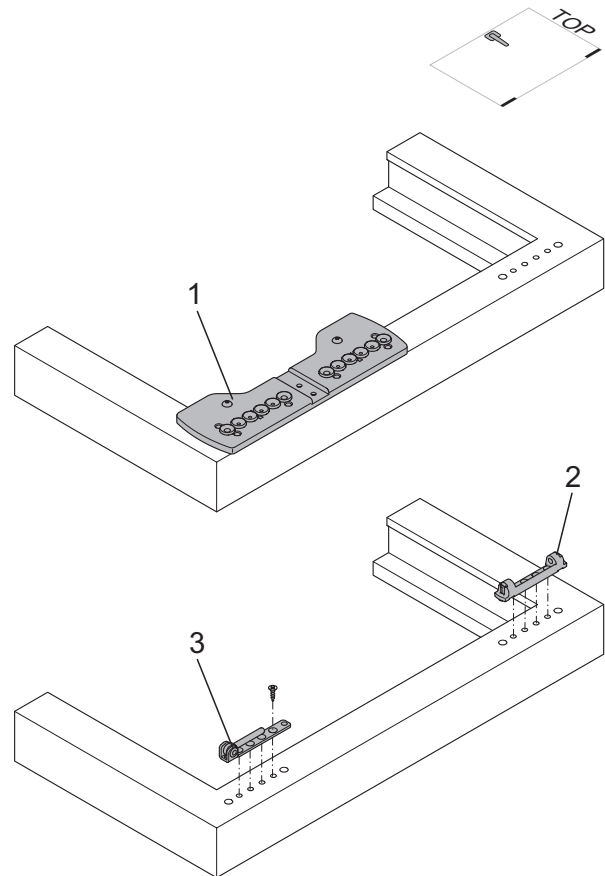

Holes for corner and shear hinges

Positions of keeps (basic equipment)

Turn-tilt type

The following figures show the keep position options. The number of keeps depends on the size of the window.



Note: The dimensions shown in the figures refer to the frame rebate edge to keep profile edge or frame centre to the keep!

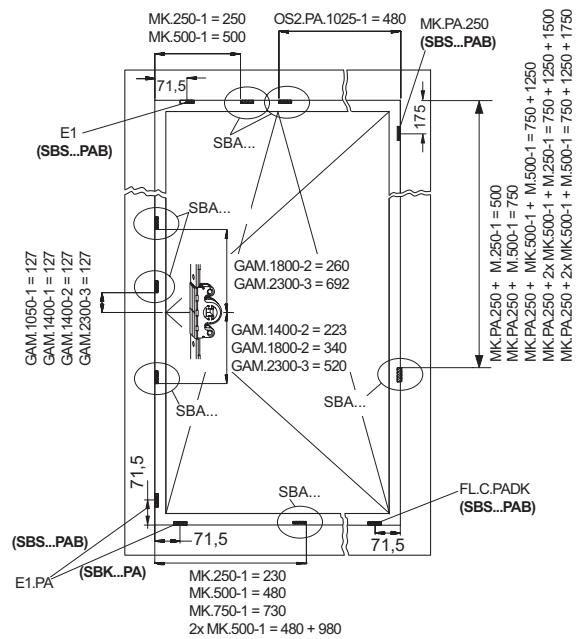

Keep positions DK "central handle position"

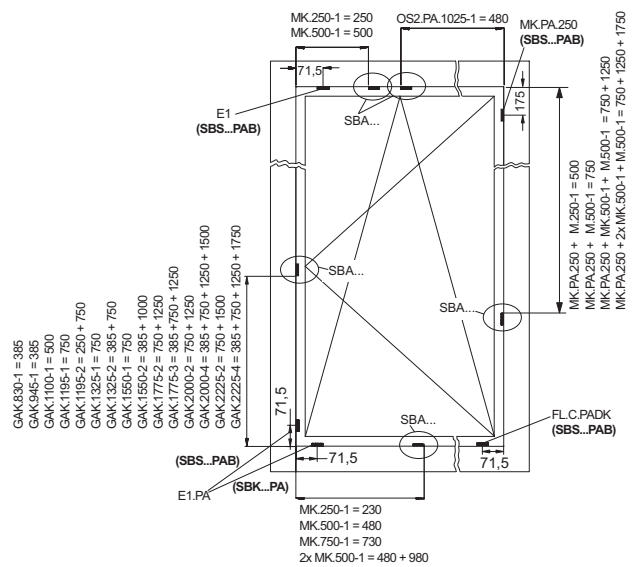

Keep positions DK "constant handle position"

Positions of keeps (RC2)

Turn-tilt type

The following figures show the keep position options. The number of keeps depends on the size of the window.



Note: The keeps marked here are security keeps SBS...PAB. Unlike SBA... keeps, the measurements refer to the "centre" of the keep.

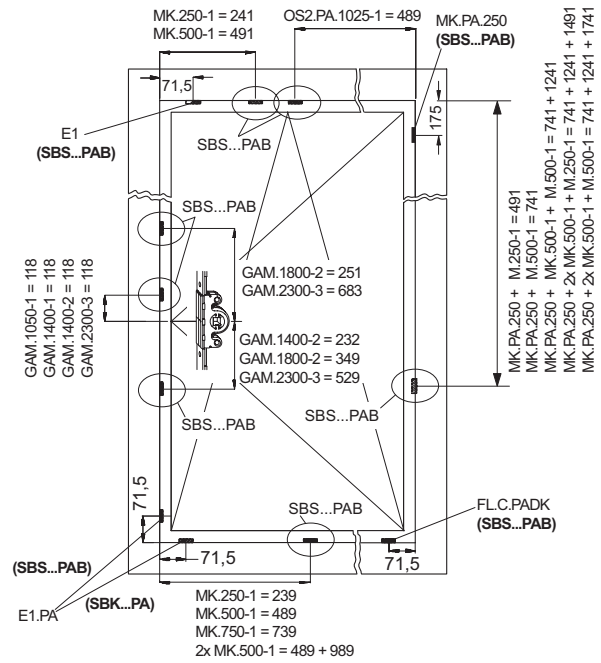

Keep positions DK "central handle position"

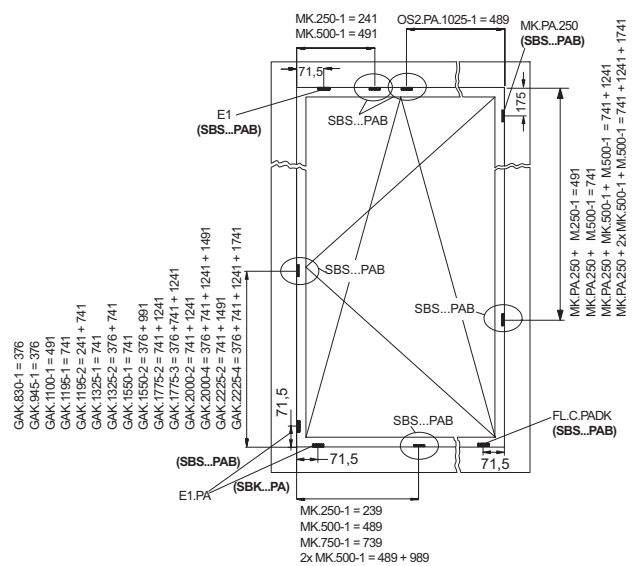

Keep positions DK "constant handle position"

Turn double sash type

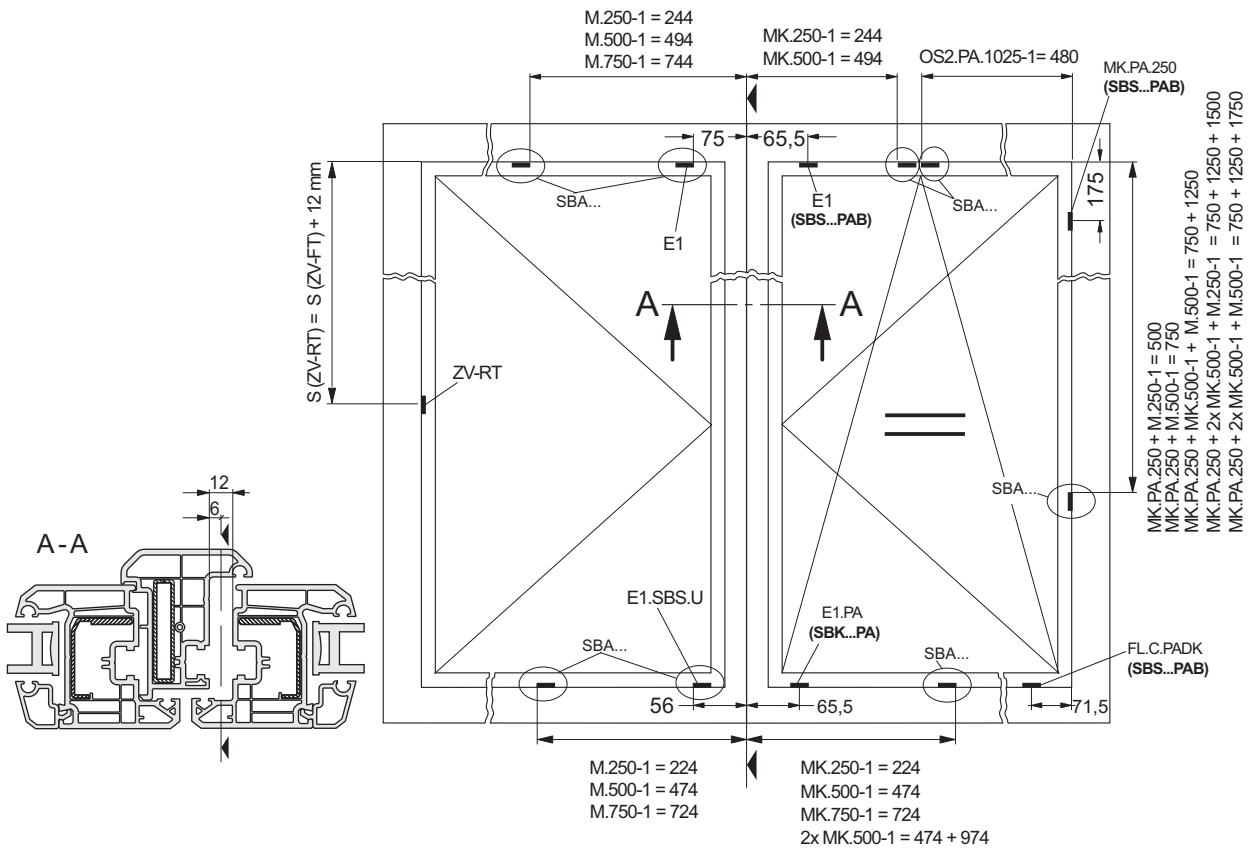

Keep positions, double sash window D/DK

Fitting the keeps

Handling of mounting jigs is explained by reference to the L.E.N.K. 710-1100 mounting jig in the following. Other mounting jigs are used in the same way. To position keeps, place the mounting jig on the frame rebate edge.

Labelling of mounting jigs



Horizontal attachment = red element (for top rod and interlocking rod)



Vertical attachment = yellow element (for drive rods and interlocking rods)



Vertical / horizontal attachment = blue element (for corner drives)



= Keep run-in

Keep SBS...PAB drive side bottom corner drive for E1.PA

See figure: SBS...PAB

- Use a PADK jig for the keeps needed for the parallel position activPilot Comfort.
- Position the mounting jig with the red element in the corner.
- Position the SBS...PAB keep on the red element marked E1.PA, FL...PA, E1.

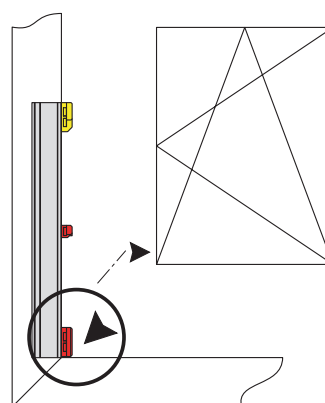

SBS...PAB

Keep SBS...PA drive side, top corner drive for E1

See figure: Keep SBS...PA

- Use a PADK jig for the keeps needed for the parallel position activPilot Comfort.
- Align the mounting jig with the red element in the corner.
- Position the SBS...PA keep on the red element marked E1.PA, FL...PA, E1.

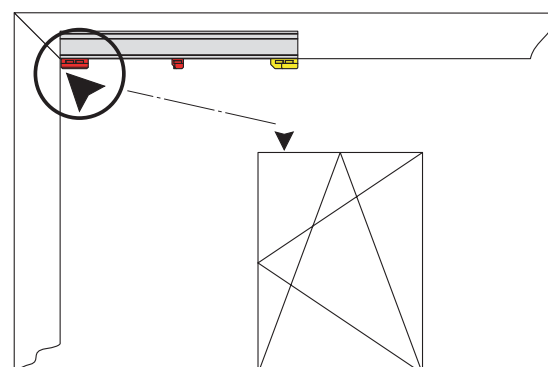

Keep SBS...PA

Keep SBS...PAB top hinge side for MK.PA.250

See figure: SBS...PAB top, horizontal

- Use a PADK jig for the keeps needed for the parallel position activPilot Comfort.
- Position the mounting jig with the yellow element in the upper corner.
- Position the keep SBS...PA.. on the red element marked MK.PA.250.

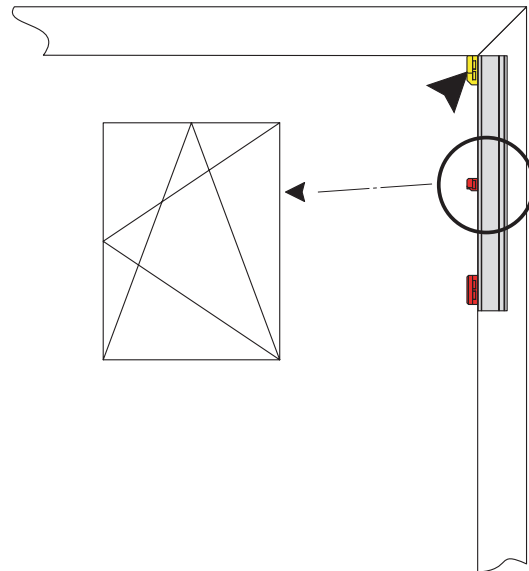

SBS...PAB top, horizontal

Keep SBS...PAB for sash hinge FL...PA bottom hinge side

See figure: Keep SBS...PAB

- Use a PADK jig for the keeps needed for the parallel position activPilot Comfort.
- Position the mounting jig with the red element in the corner.
- Position the SBS...PAB keep on the red element marked E1.PA, FL...PA, E1.

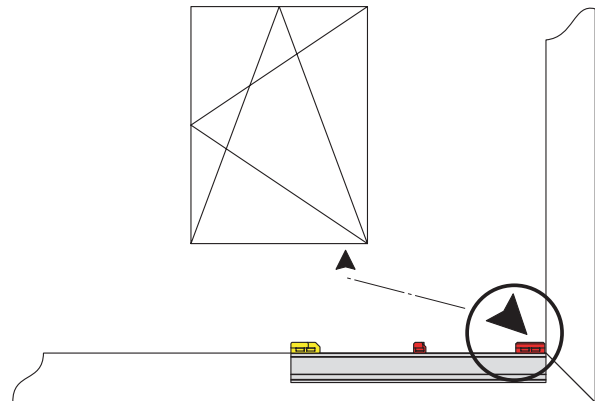

Keep SBS...PAB

Keep for top rod OS...

- Align the mounting jig with the red element in the top corner.
- Place the keep SBA on the blue element labelled "OS. ...".

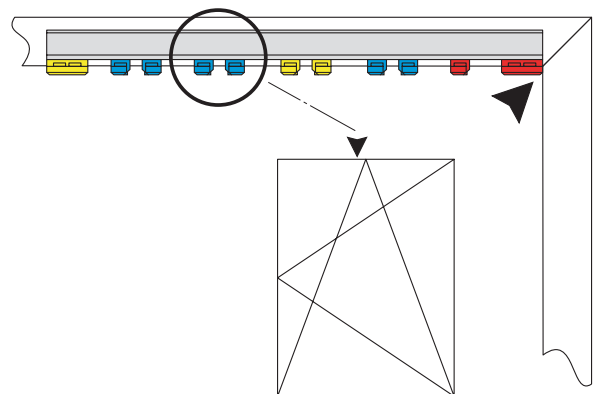

Keep for top rod OS...

Keeps SBA... for vertical GAK

- Align the mounting jig with the yellow element in the bottom corner.
- Place the SBA. ... keeps on the yellow and blue elements marked "GAK. ...".

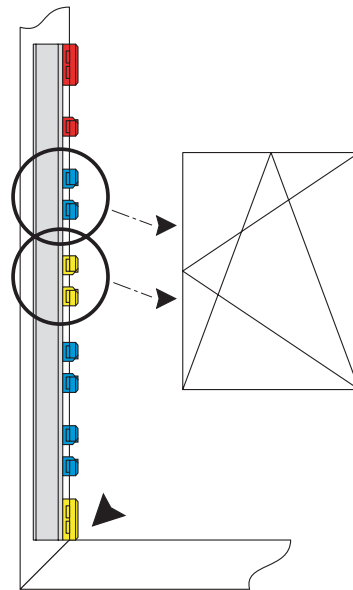

SBA... for vertical GAK

Keep SBK...PA horizontally at the bottom for E1.PA

See figure: Keep SBK...PA

- The keep can be placed without using a jig.
- Position the keep in the bottom corner.

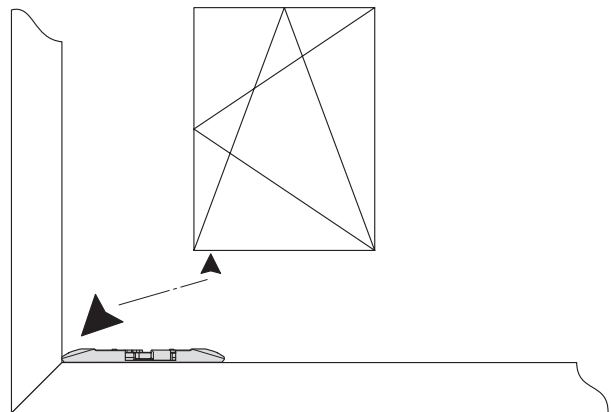

Keep SBK...PA

Keeps for GAM

- Attach the corresponding mounting jig labelled “top” or “bottom”.
- Fit keeps in line with the labelling on the mounting template.

There are three telescopic jigs depending on the window height:

- LE.N.T. 0710-1050 for drive rod GAM 1050-1
- LE.N.T. 1051-1800 for drive rod GAM 1400-1/2 / 1800-2
- LE.N.T. 1801-2300 for drive rod GAM 2300-3

i Note: The labelling on the drive rod must match the labelling on the yellow templates.

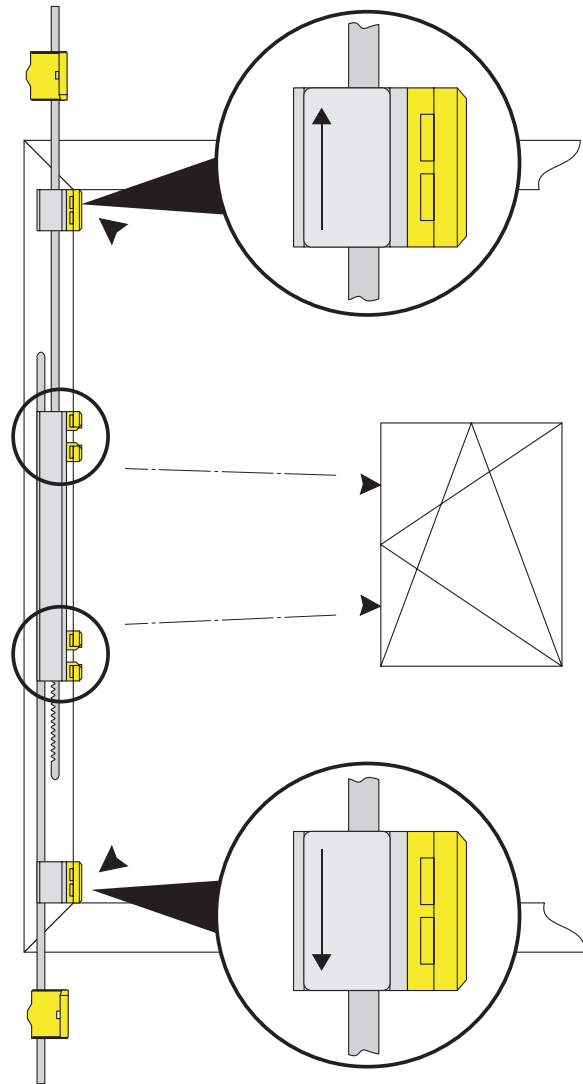

Keeps for GAM

Keep for interlocking rod M or MK hinge side in shear hinge area

See figure: Keeps hinge side

- Align the mounting jig with the yellow element in the top corner.
- Position the keep for interlocking rod on the yellow element.

i Note: The labelling on the interlocking rod must match the labelling on the yellow templates. The interlocking rod MK is labelled e.g. "MK.750-1".

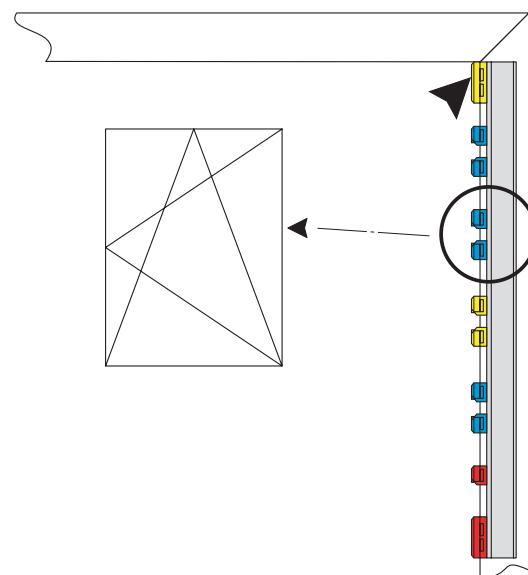

Keeps hinge side

Interlocking Rod M..., bottom, horizontal

See figure: M bottom horizontal

- Align the mounting jig with the red element in the lower corner.
- Position the keep on the blue element marked "M" or "MK".

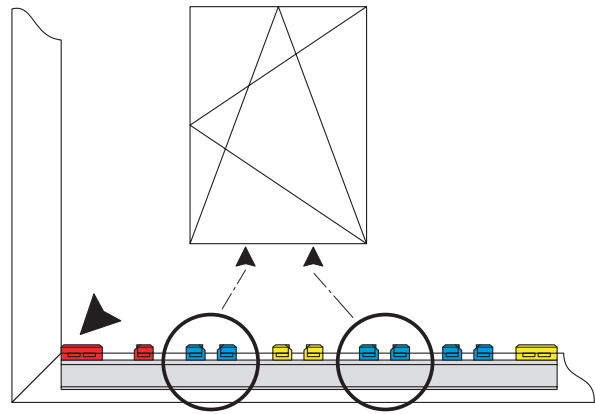

M bottom horizontal

Mounting shear and corner hinges

See figure: Shear and corner hinges

- Fix the shear hinge (2) and corner hinge (1) with screws.



Note: Window builders must ensure that hinges and their anchorings are designed to support the expected loads and professionally mounted.

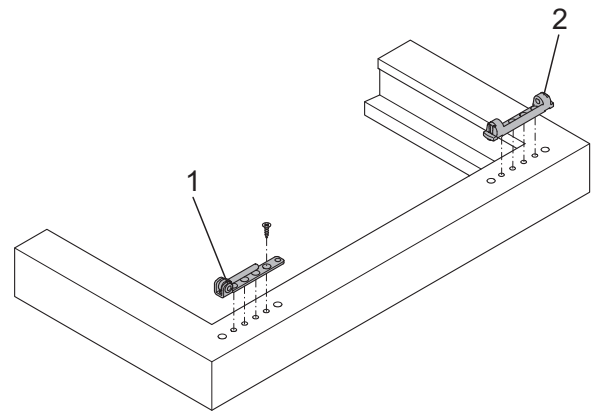

Shear and corner hinges



Important: The screw connections of the load-bearing fitting components, such as corner, shear and sash hinges must be performed according to the TBDK guidelines. Adapt the drilling diameter for the fixing screws, the screw diameter and the screw length to the load situation.

Sash installation and removal

Surface-mounted hinge parts

Fitting the sash

- Mount the sash, adjust for a good seal and fit the pin to secure against the shear hinge.
- Push all end caps and sealing caps onto the shear and corner hinges.

i Note: Insert the pin from the underside (see arrow).

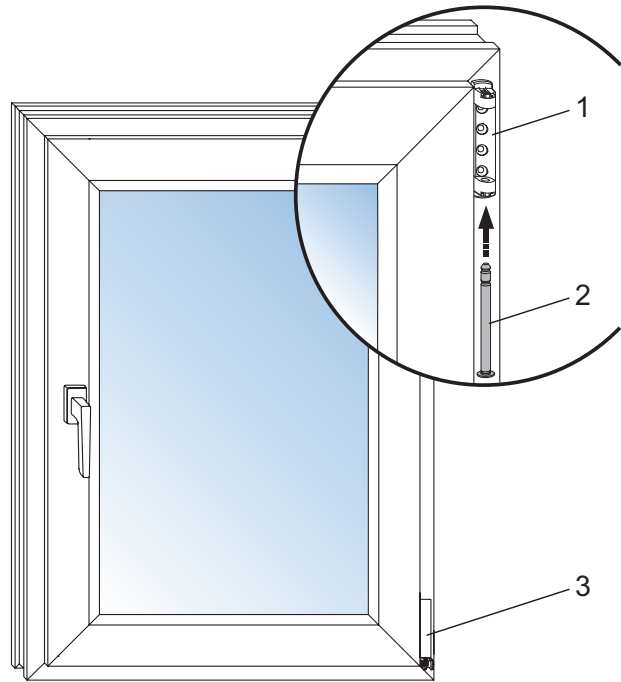

Shear and corner hinge

Removal of the sash

- Close the sash.
- Release the pin from the shear hinge.
- Remove the sash.

! Please note! Damage to shear hinge. In case of improper use and if you attempt to drive out the pin forcibly, the scissor stay will be damaged. Use only a screwdriver or pin-pulling device to release the pin as shown in the figure.

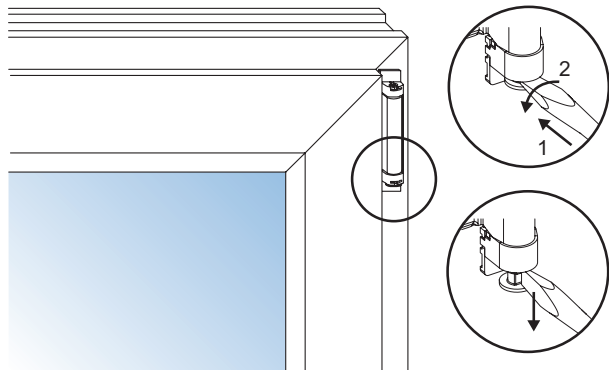

Support the sash!

! In order to save the sash hinge and corner hinge from damage, sagging of the sash during assembly must be prevented (give horizontal support)!

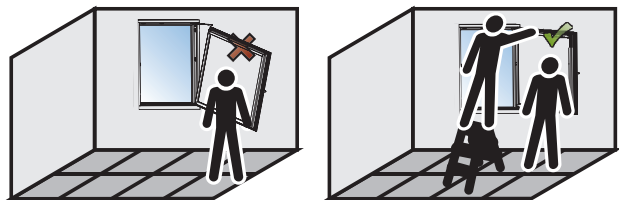

! Important: Secure the window sash against falling. Take the heavy sash weight into account!

Notes on professional fitting and removing of sashes

Notes on professional mounting and dismantling of window sashes are given on our mounting advice. We recommend to place this mounting advice on the window sash.

i For withdrawing the shear hinge pin we recommend you to use the pulling device (see product page). If a screwdriver is used, please make sure that the powder coating of the hinge is not damaged.

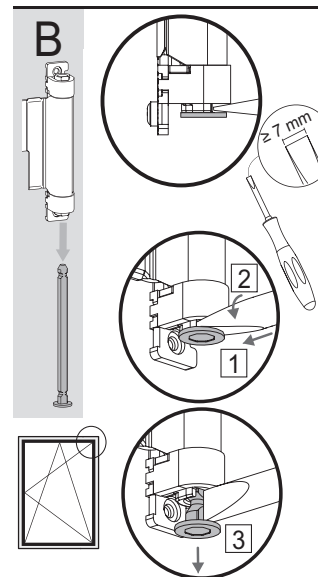
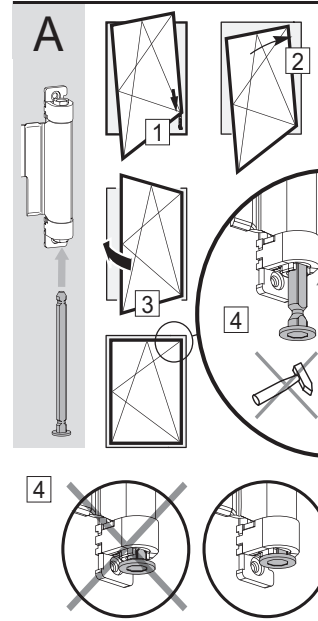

FT JTMV - 01/2020 - Printno. 996 000 584 - Maßno. 5076353

13.3

Operation / operating sequence

activPilot Comfort PADK

Operating sequence: locked – tilt position – parallel action – turn position

- If the handle is moved to the crosswise position from below, the fitting is in the tilt position. The sash is brought into the parallel position by turning further by 90° to the 180° position. If the handle is turned back to the 90° position, the window sash can be moved to the turn position. To close the window, the handle must be turned downwards to the initial position.

 Burglar resistance according to DIN 18104-2 only in these positions. The handle must be securely locked.

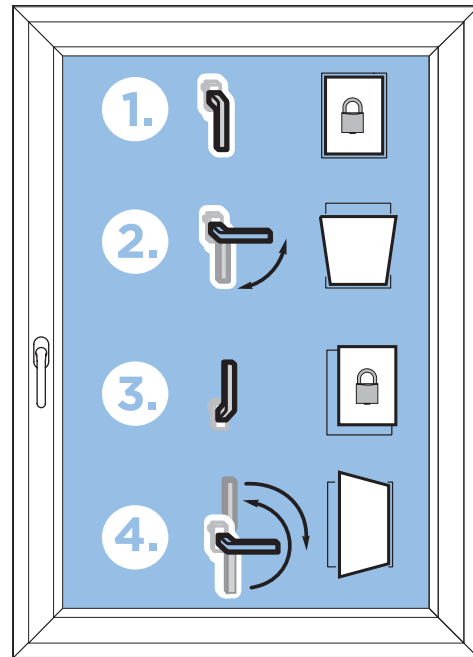

Operating sequence for operation via the window handle

Technology and function description

See figure: Function SBK.K.PA

- The window is closed (1) when the corner drive bolt as well as the slider are located on the exterior side of the tilt keep.
- Turning the handle by 90° you will reach the tilt position with the corner drive bolt and the slider being in the centre position (2).
- When the handle is moved into the 180° position the window is in the parallel opening position with the corner drive bolt and the slider being on the outer face of the tilt keep (3).
- When the handle is turned back to the 90° position, the corner drive bolt moves back to the centre position while the slider remains at the exterior side. The window can be opened fully (turn position, 4).

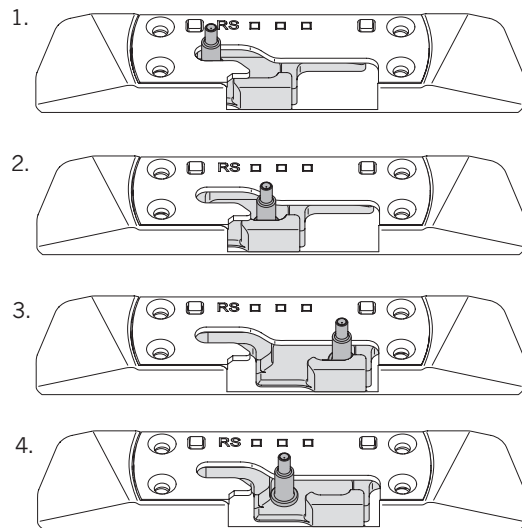

Function SBK.K.PA

Operating and maintenance instructions for the window company

General notes and safety advices

activPilot

These instructions are intended for the window company. They describe essential adjustment and maintenance work for activPilot fittings. Please observe the following notices: Fitting parts are to be tested regularly to ensure they are seated firmly and checked for wear. Fastening screws are to be retightened and parts replaced as necessary. Their functionality is to be retested afterwards. Fittings may only be cleaned with mild, ph-neutral cleaning agents in diluted form. Use only cleaning agents which do not degrade the corrosion protection on fitting parts. Never use aggressive, acidic or caustic cleaners, scouring agents or sharp objects to clean fitting parts. Always also observe the guideline for product specifications/notices and liability when making adjustments or performing maintenance.

This information can be obtained at the following Internet address:

<http://www.beschlagindustrie.de/ggsb/richtlinien.asp>

Combination of corner hinge / sash hinge EL.C... and FL.C

Sash hinge without additional function

Sash hinge height adjustment (± 3 mm) and corner hinge side adjustment (± 2 mm) with 4 mm Allen key

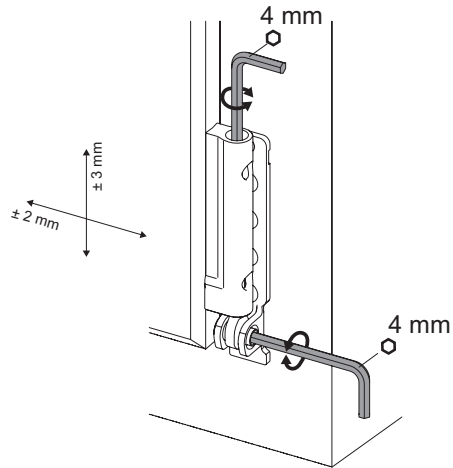

Sash hinge without additional function

Octagonal bolt

Regulate the contact pressure between the sash and the frame (± 0.8 mm) by turning the octagonal bolt. The adjustment can be carried out by means of the Winkhaus adjustment key (V.ST.SCH.HV-11).

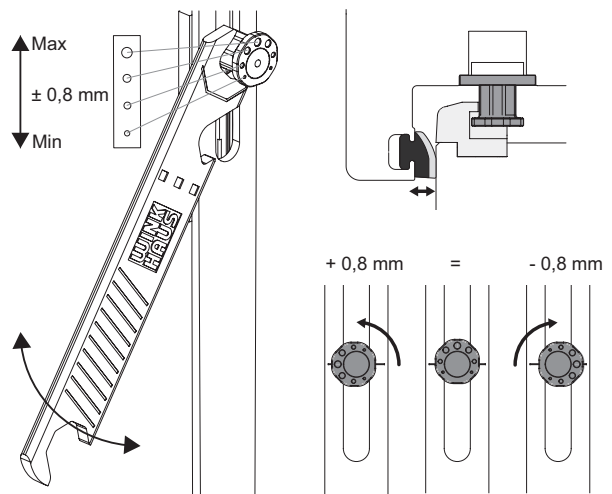

Octagonal bolt

Shear retraction

The progressive shear pull-in is adjustable from 18 to 28 mm. Release the catch by pulling up on the adjustment latch then pivot the adjustment latch away from the overlap.

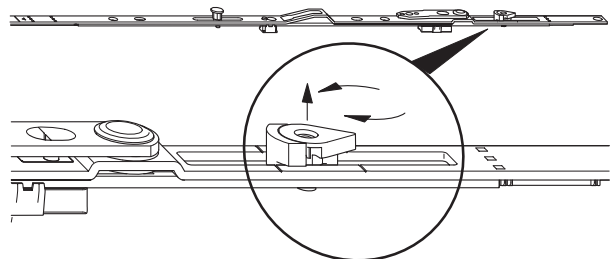

Shear retraction

Shear - rectangular window

Lifting and lowering the sash by means of a 4 mm Allen key.

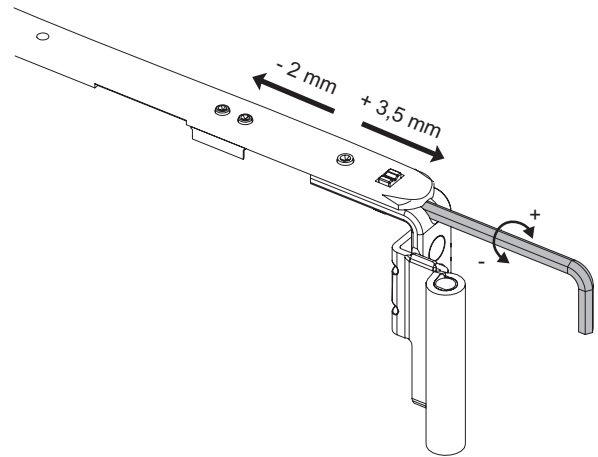

Shear - rectangular window

Maintenance

Lubrication points

See figure: Overview of lubrication points

The figure shows the location of possible lubrication points which should be lubricated at least once a year (every six months for school and hotel buildings).

Positions A, C, D = lubrication points relevant to function.

i Note: the fitting schematic shown adjacent does not necessarily match the existing fitting. The number of locking positions will vary depending on size and type of the window sash.

! Please note! Risk of injury. The window could fall on removal and thus injure persons. Do not remove the window for maintenance.

Shears

See figure: Shears

All of the shear's contact points with the top rod should be oiled at least once annually.

i Note: The shear hinge must not be oiled or greased.

! Note: Please make sure the shear is clean in the upper area.

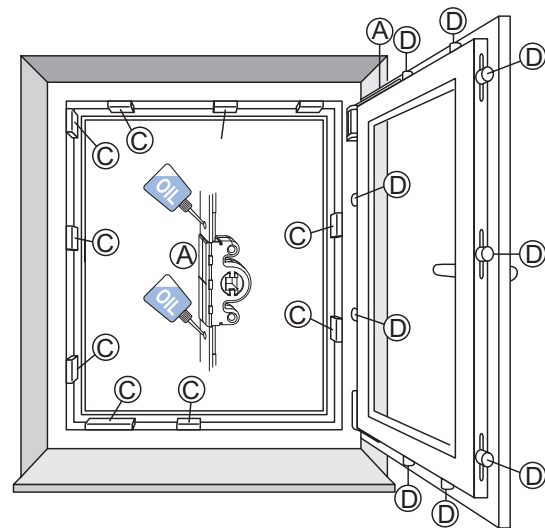

Overview of lubrication points

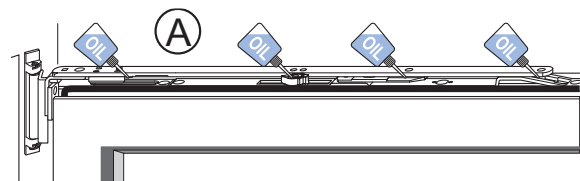

Shears

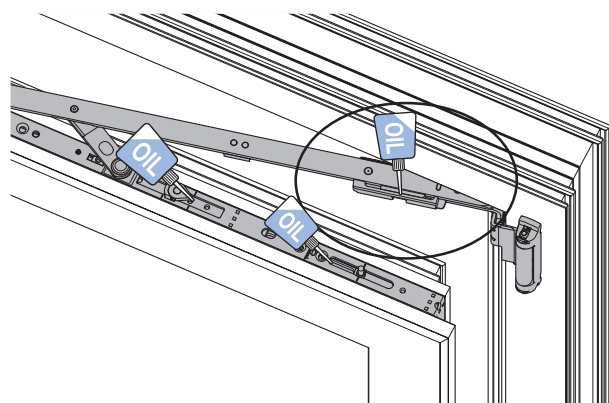

Protection from dirt and dust

Sash hinges

See figure: Sash hinges

All moving contact points on the sash hinge should be greased with a suitable lubricant once annually.
Coat lubricating points with non-resinous, non-corroding grease.

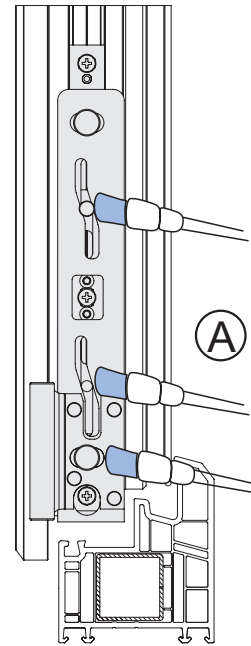

Sash hinges

Locking keeps

See figure: Locking keeps

To keep fittings running smoothly, you must lubricate the keeps at least once a year.

- Lubricate the keeps (C) at the run-in side with technical Vaseline or any other suitable grease.
- Coat the running surfaces of the locking bolts (D) with an oil that is free of resins and acids.
- The tilt keep must be clean!

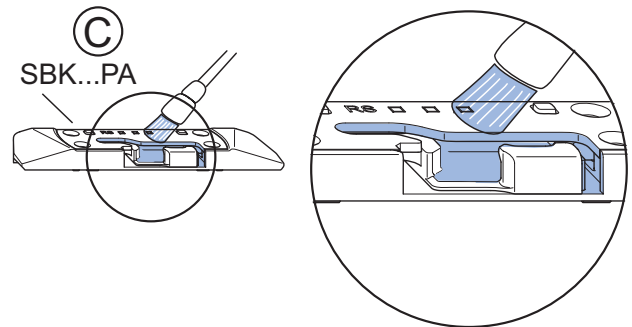
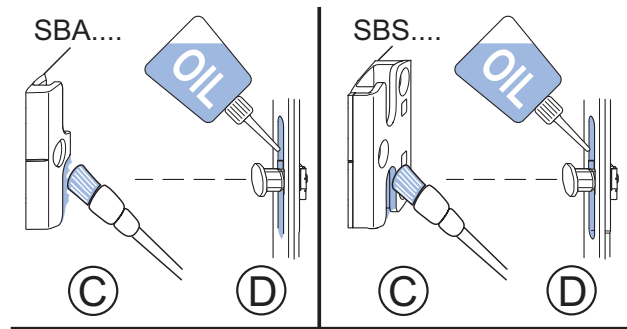

Locking keeps



Note: The interior adjustment mechanism of the keep must not be moved.



Note: The running surfaces of the adjustment mechanism of the keep must be kept clean.

Ascertaining the run-in sides

See figure: Run-in sides

- Left-handed window; handle right
- Right-handed window; handle left

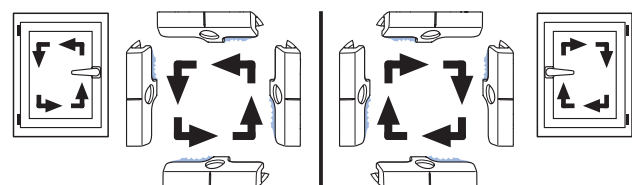

Run-in sides

Installation drawings

Drive rods

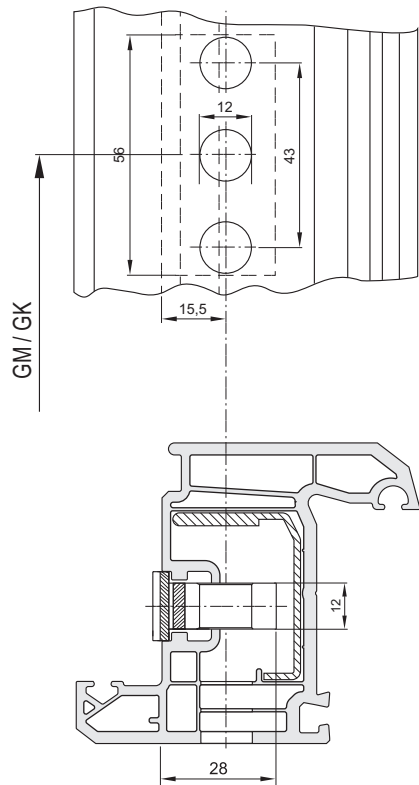

B-3-1: Drilling and milling template GAK/GAM ... D = 15.5 mm

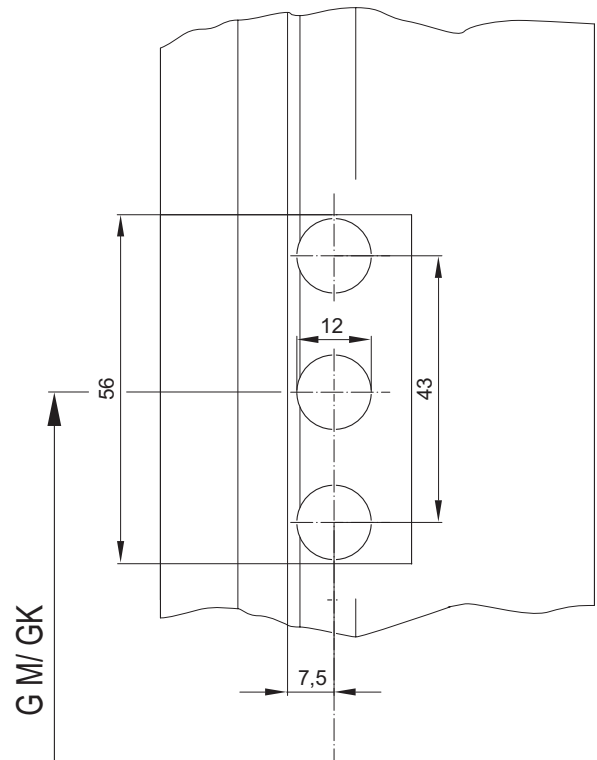

B-3-2: Drilling and milling template GAK/GAM ... D = 7.5 mm

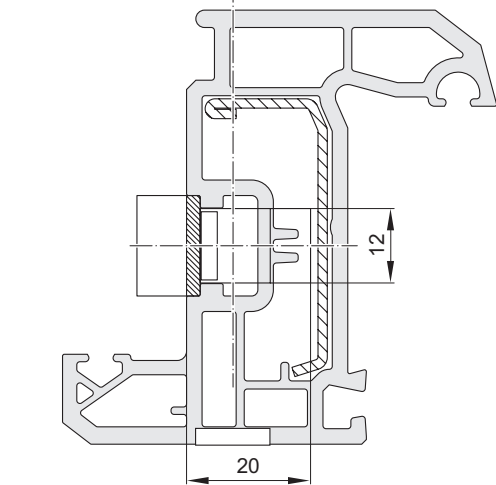

B-3-4: Drilling and milling template GAK/GAM ... D 25 ... 50
D = Backset

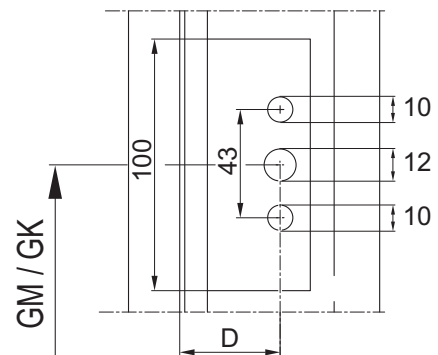

Corner hinge EL.CS and shear hinge SL.C

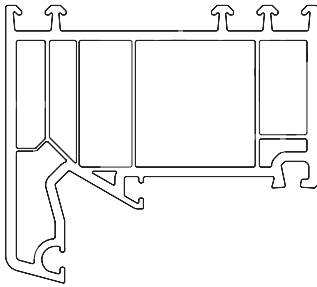

| | Ø(Z) [mm] | L [mm] |
|-----------|--------------|-----------|
| SL.C.3-3 | 3 | 3 |
| SL.C.3-6 | 6 | 3 |
| SL.C.22-6 | 6 | 22 |

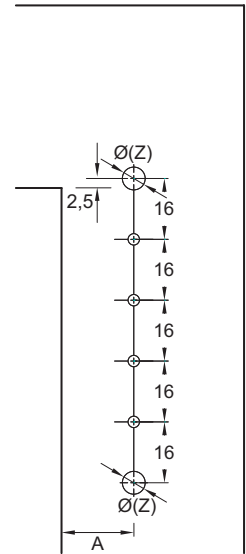
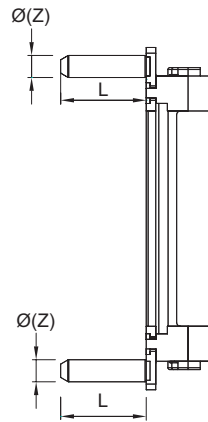
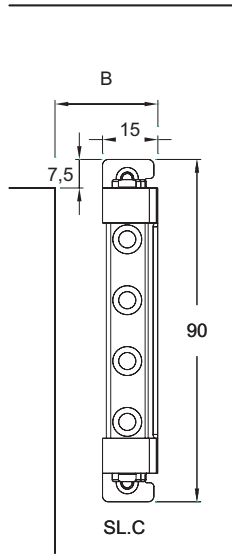

| UEB [mm] | A [mm] | B [mm] |
|-------------|-----------|-----------|
| 20 | 19 | 27 |
| 21 | 20 | 28 |
| 22 | 21 | 29 |

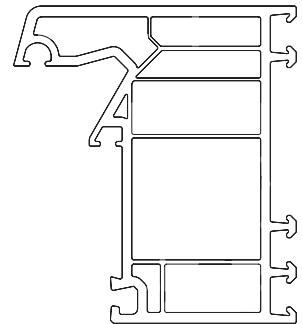

| | Ø(Z) [mm] | L(1) [mm] | L(2) [mm] |
|---------------|--------------|--------------|--------------|
| EL.CS.3-3-3 | 3 | 3 | 3 |
| EL.CS.6-3-3 | 6 | 3 | 3 |
| EL.CS.6-3-10 | 6 | 3 | 10 |
| EL.CS.6-3-22 | 6 | 3 | 22 |
| EL.CS.6-10-10 | 6 | 10 | 10 |
| EL.CS.6-22-3 | 6 | 22 | 3 |

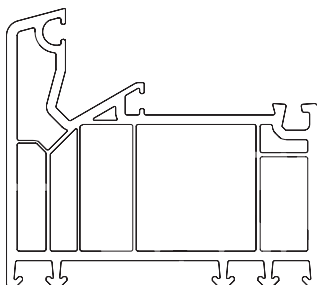
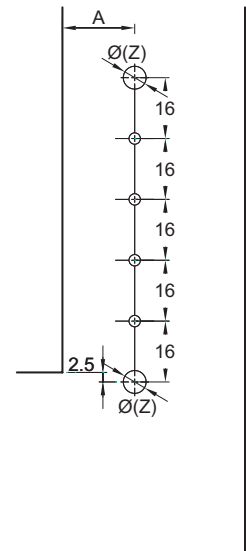
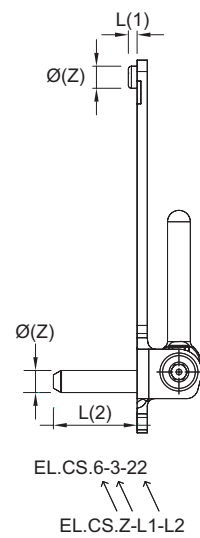
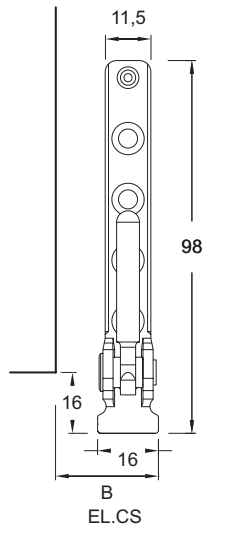

B-6-2: Drilling template shear hinge SL.C (top) corner hinge EL.CS (bottom)
UEB = overlap

| | | Page | |
|-----------|------------------------------------|-----------|-----------|
| 1 | General product information | 125 - 128 | 1 |
| 2 | Lists of Fittings | 129 - 139 | 2 |
| 3 | Drive rods | | 3 |
| 4 | Corner drives | | 4 |
| 5 | Top rods | | 5 |
| 6 | Sash hinges/Corner hinges | 140 - 143 | 6 |
| 7 | Shears/Shear hinges | 144 - 146 | 7 |
| 8 | Turn hinges/Tilt hinges | | 8 |
| 9 | Extension rods | | 9 |
| 10 | Accessories | 147 - 149 | 10 |
| 11 | Frame parts | 150 | 11 |
| 12 | Mounting accessories | 151 - 154 | 12 |
| 13 | Installation Instructions | 155 - 182 | 13 |
| 14 | Adjustment/maintenance | 183 - 186 | 14 |
| 15 | Installation drawings | 187 - 189 | 15 |
| 16 | activPilot Comfort PADM | 125 - 189 | 16 |
| 17 | activPilot Comfort PADS | 191 - 252 | 17 |
| 18 | activPilot Comfort PAD | 253 - 313 | 18 |

activPilot Comfort PADM

The parallel action turn fitting system for motorised drives.

activPilot Comfort PADM can perform many tasks at the same time.

Winkhaus has therefore developed the unique fitting system activPilot Comfort PADM, which can effectively carry a variety of tasks. The fitting in combination with the HF.MD.PADM drive enables rooms to be ventilated naturally with burglar resistance remaining at a high level. It helps to create good room air quality and to establish a positive energy efficiency results. With activPilot Comfort PADM, rooms can also be ventilated when noone is present. Unwanted guests are kept outside while the room is being ventilated, the amount of driving rain and traffic noise coming through the window is significantly reduced.

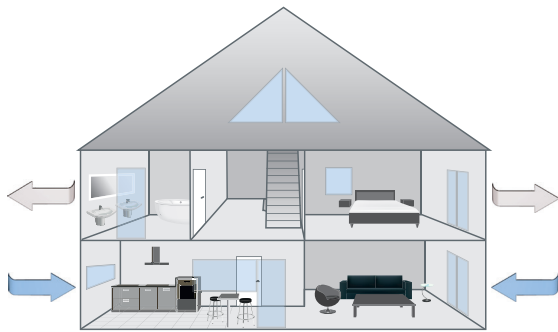

Standards and instructions

German Building Energy Act (GEG)

The energy saving regulations stipulate that buildings be tight when they are built or refurbished. This legal provision even applies to the restoration of old buildings when 1/3 of the entire building is replaced or rebuilt. The law also applies if a building volume is increased by at least 30 m³ or expanded by a room of corresponding size (in addition, building regulations, among other things, for fire, sound and monument protection). The planned building must be compared with a reference building (in accordance with the GEG act). If there are deviations at a point from the reference building, it must be ensured that appropriate compensation is provided.

DIN 1946-6:2019-12

In §13 of the GEG Act, permanent building tightness and a sufficient minimum air exchange are required. DIN 1946-6:2019-12 provides this proof. A ventilation concept must be established in order to meet the requirements of this standard. The result of such a ventilation concept is: The building is sufficiently ventilated or additional measures are necessary to achieve the minimum air exchange. If there is adequate ventilation, no ventilation measures are required. If ventilation measures are required, the standard states that energy exhaust air systems must either be user-independent, regulated as required or equipped with a heat pump.

| Ventilation measures | | | | |
|---|--------------------------|---------------|---------------------------------|---------------------------------|
| Necessity of ventilation measures - refurbishment Implementation according to DIN 1946-6:2019-12 | | | | |
| Utilisation unit | Thermal protection Level | Site location | Low occupancy ¹ | High occupancy ² |
| single storey (n50 = 1.5 h ⁻¹) | low | weak wind | yes | yes |
| | | strong wind | yes (up to 120 m ²) | yes |
| | high | weak wind | yes | yes |
| | | strong wind | no | yes (up to 120 m ²) |
| multi-storey (n50 = 2.0 h ⁻¹) | low | weak wind | yes (up to 120 m ²) | yes |
| | | strong wind | no | yes (up to 80 m ²) |
| | high | weak wind | no | yes (up to 120 m ²) |
| | | strong wind | no | no |

| Necessity of ventilation measures - new construction Implementation according to DIN 1946-6:2019-12 | | | | |
|--|--------------------------|---------------|--------------------------------|---------------------------------|
| Utilisation unit | Thermal protection Level | Site location | Low occupancy ¹ | High occupancy ² |
| single storey (n50 = 1.5 h ⁻¹) | high | weak wind | yes | yes |
| | | strong wind | no | yes (up to 120 m ²) |
| multi-storey (n50 = 2.0 h ⁻¹) | high | weak wind | yes (up to 80 m ²) | yes |
| | | strong wind | no | yes (up to 80 m ²) |

¹ usable area of ≥ 40 m²/person with planned use, usually owned

² usable area of < 40 m²/person with planned use

Effective ventilation with activPilot Comfort PADM

Compared to conventional turn-tilt windows, the activPilot Comfort PADM fitting system provides three functions: locked - parallel action - turn position. Winkhaus has consistently pursued its strategy as market leader in parallel action and developed an automated variant. In addition to the turn opening, the fitting enables the parallel action of the window sash as a motor-controlled window position for user-independent room ventilation. This position creates a ventilation gap just 6 mm wide between the frame and window sash, enabling natural and gentle ventilation under any weather conditions. The natural exchange of air thus ensures a healthy

indoor climate. Ventilation with fully-opened sashes as with a conventional window is still possible.

The special feature: The parallel opening position (rectangular windows) enables the same burglar resistance as the closed position of the window, burglar resistance to DIN EN 1627-1630 up to resistance class RC2. The innovation: Burglar-resistant ventilation!

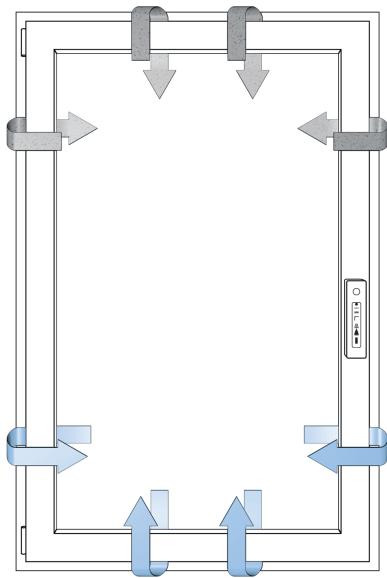

Operation and manufacturer-friendly system

activPilot Comfort PADM in combination with fitting drive HF.MD.PADM provides natural air exchange as per DIN 1946-6. As ventilation scenarios, such as preset ventilation times, can be set, indoor rooms can be supplied with natural fresh air independently of the user. To open the window fully, just press a button and the fittings motor drive releases the sash for the turn position. The window can then be opened manually as usual.

The wireless remote control makes the use of hard-to-access windows more convenient. The functionality of this contemporary ventilation system is made complete by minimal power consumption, low-noise operation and backlit touch operation surfaces with self-explanatory button icons. Like all Winkhaus fittings, activPilot Comfort PADM is particularly manufacturer-friendly and can be easily implemented with just a few additional elements from the activPilot Concept series.

The innovative activPilot Comfort PADM window system is a real alternative to conventional ventilation systems.

In order to ascertain the amount of air that can be exchanged against the pressure difference, you can use the chart to determine the volume flow per running metre (sash rebate sizes).

Example:

With a pressure difference of 2 Pa there is an exchange of air of approx. 10.7 m³/h per running metre. This means that the air that is exchanged through a window 1 x 1 m amounts to 42.5 m³/h.



The information given refers to a ventilation gap of approx. 6 mm.

Wind velocities

| Pa | m/sek | km/h | Windstärke in BF |
|-----|-------|-------|------------------|
| 2 | 1,8 | 6,6 | 2 |
| 3 | 2,2 | 8,1 | |
| 4 | 2,6 | 9,3 | |
| 5 | 2,9 | 10,4 | |
| 8 | 3,5 | 12,7 | 3 |
| 10 | 4,1 | 14,7 | |
| 15 | 5,0 | 18,0 | |
| 20 | 5,8 | 20,8 | 4 |
| 50 | 9,1 | 32,9 | 5 |
| 100 | 12,9 | 46,5 | 6 |
| 300 | 22,4 | 80,5 | 9 |
| 600 | 31,6 | 113,8 | 11 |

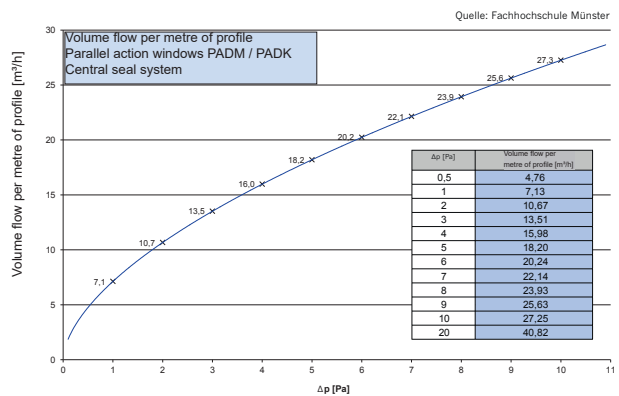

activPilot Comfort PADM

Application diagram for ascertaining the admissible sash sizes

- Max. sash weight 100 kg

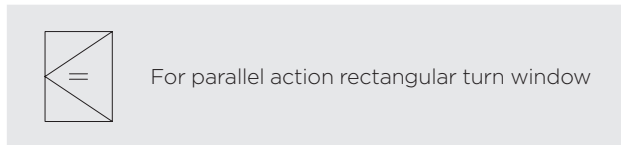
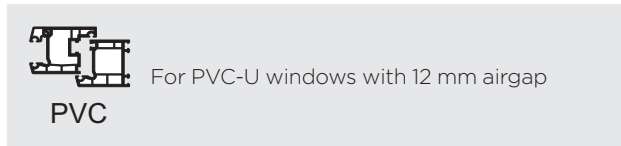

Width-to-height ratio and additional load

Value calculated without additional load for a width-to-height ratio of 1.5:1.

The application graphs have been calculated without additional loads. Please consult your authorised contact person for further information on how to calculate the maximum permissible window sash format with an additional load.

Advice for use

The application range permitted for using Winkhaus fitting is highlighted in grey in the application graphs. However, it is essential not to use the entire grey-highlighted section, but only those parts which are on the left-hand side of the curve for the respective GG filling weight.

Application range

The respective overall fitting must be selected from the original Winkhaus activPilot fitting components range. Winkhaus accepts no liability if non-original or unauthorised system accessory parts are used.

- Min. sash rebate width 460 mm
- Max. sash rebate width 1475 mm
- Min. sash rebate height 695 mm (surface-mounted cable transition)
- Min. sash rebate height 820 mm (concealed cable transition)
- Max. sash rebate height 2300 mm
- Max. sash size 2.5 m²
- Max. sash weight 100 kg
- Ratio between sash rebate width: Sash rebate height ≤ 1.5
- Airgap 12 mm
- Overlap 20 mm
- Groove centre position 13 mm
- Frame rebate depth min. 29 mm
- Approved for centre gasket systems and rebate sealing systems with rain guard.

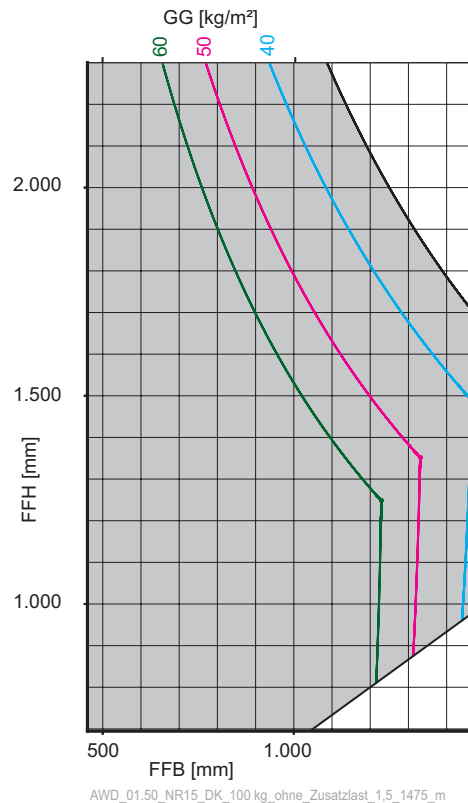

Abbreviations

- FFB = Sash rebate width [mm]
- FFH = Sash rebate height [mm]
- GG = Glass weight per square metre [kg/m²]

Observe instructions on window profile

You must specifically take into account information provided by the profile manufacturer or system owner when determining the maximum sash sizes and sash weights!



Important: The screw connections of the load-bearing fitting components, such as corner, shear and sash hinges must be performed according to the TBDK guidelines. Adapt the drilling diameter for the fixing screws, the screw diameter and the screw length to the load situation.

System Testing RC2 (Resistance Class 2)

The RC2 processing details can be gathered from the RC2 system tests. The RC2 fitting lists in this catalogue are only application examples. Get in touch with your Winkhaus contact partner for more details.



Note: activPilot Comfort fittings are not suitable for use in panic doors! They are not recommended for passage doors.

Quick orientation

Our register system allows you to quickly allocate the listed component to the item in the fitting overview drawing. The item number specifies the chapter number in which the component can be found.

11.7
SBS.K.PAD

activPilot Comfort PADM

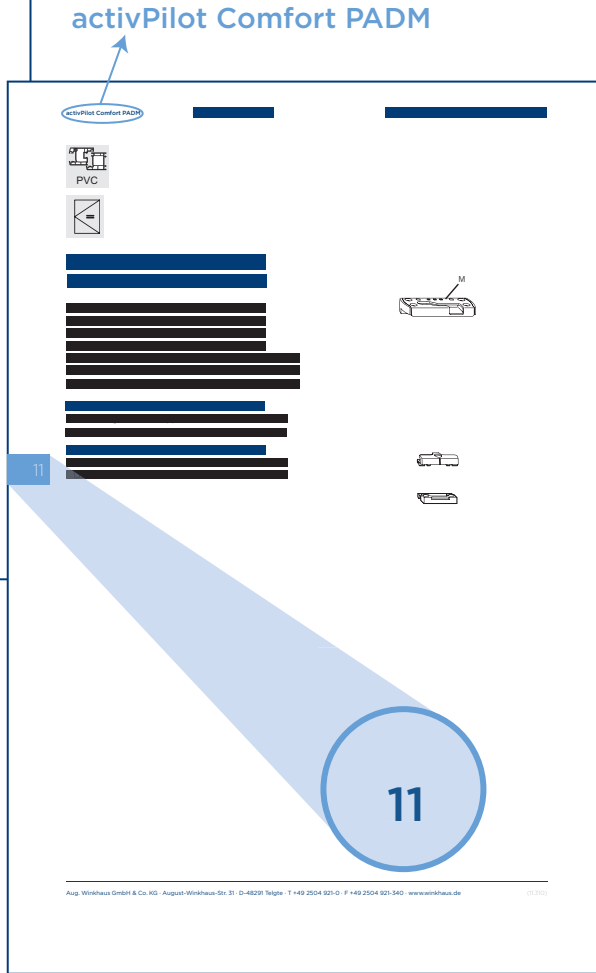
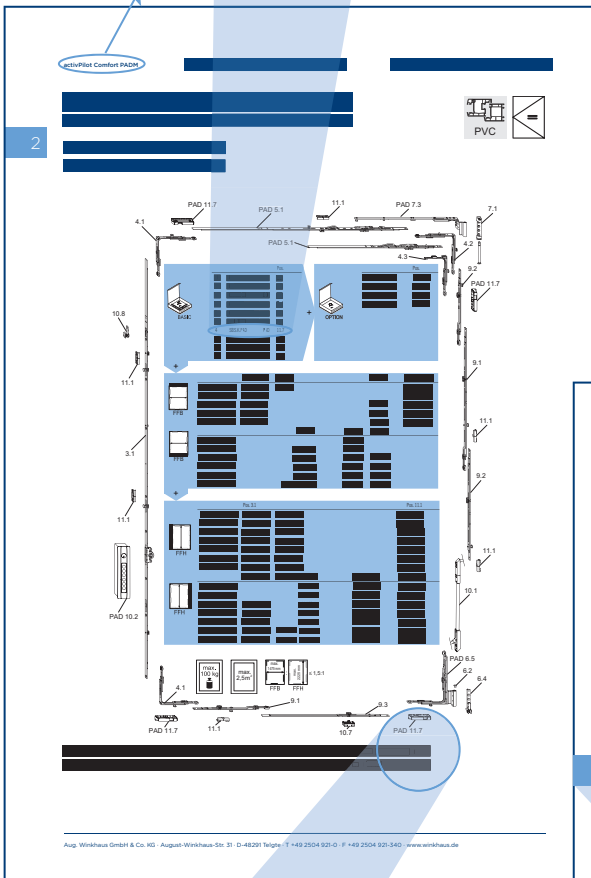

11.7

11

Lists of Fittings

| | |
|--|-----|
| Turn fitting system – constant handle position Basic equipment activPilot Comfort PADM | 132 |
| Turn fitting system – central handle position Basic equipment activPilot Comfort PADM | 134 |
| Turn fitting system – constant handle position Suitable for burglary-resistant windows RC2 / RC2 N activPilot Comfort PADM | 136 |
| Turn fitting system – central handle position Suitable for burglary-resistant windows RC2 / RC2 N activPilot Comfort PADM | 138 |

Turn fitting system - constant handle position

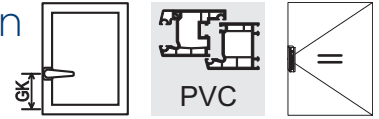

Basic equipment
activPilot Comfort PADM

2

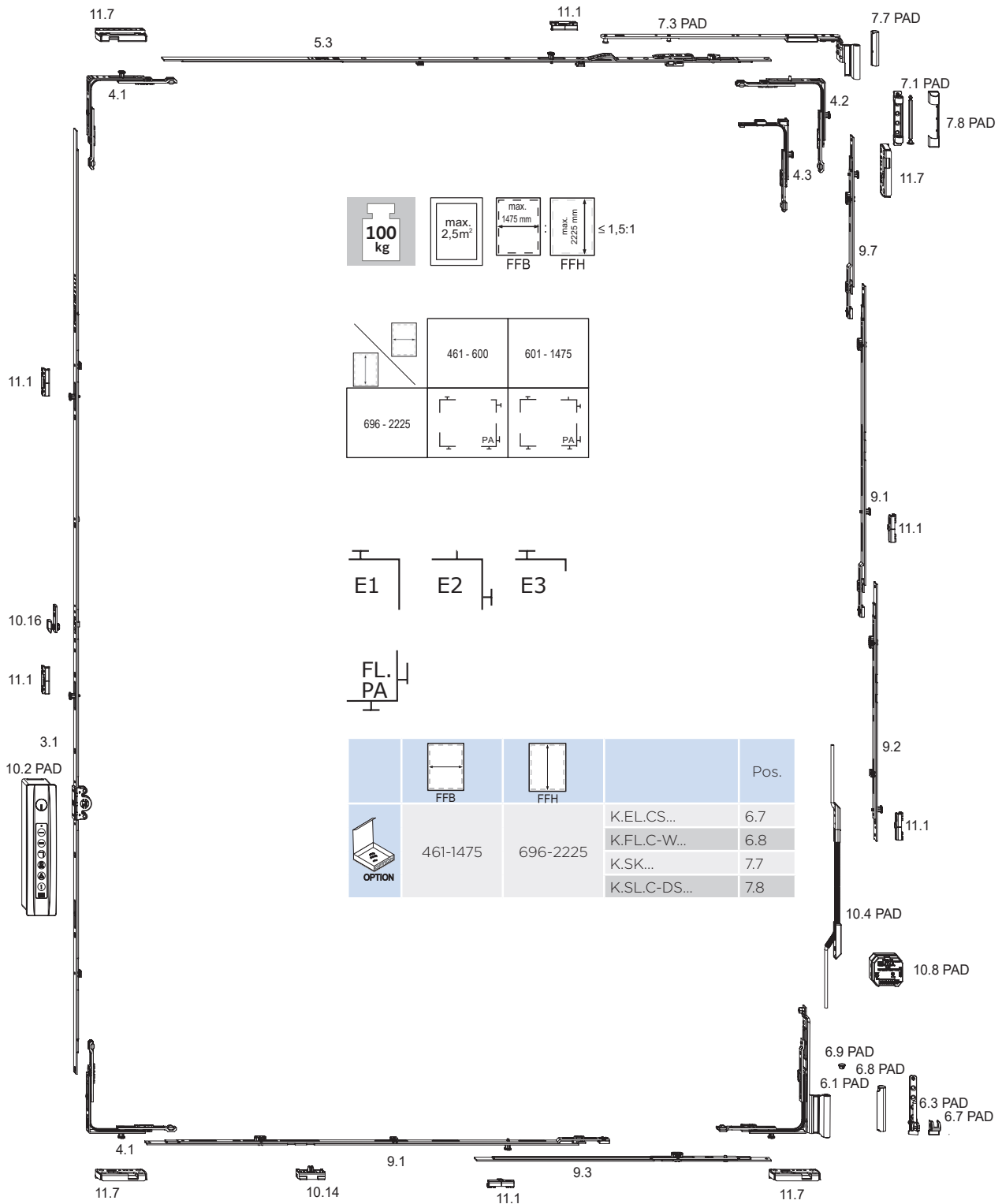

Note: You will find the components marked PAD on the following pages. All other parts can be found in the activPilot Comfort PADK section.

For small sash heights it is important to use a surface-mounted cable transition!

The shown distance between locking points is 800 mm.







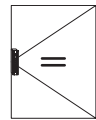
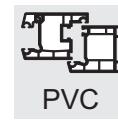
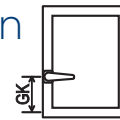



The locking distances must be agreed with the system provider.

Turn fitting system - constant handle position

Basic equipment



2

| |  |  | | Pos. | | Pos. | | Pos. | | Pos. | | | |
|---|---|---|--------------|--------------|----------|----------|-------------|-------------|-------------------------|--------------------------|--------------|----------|--|
|  | 461-1475 | | 696-2225 | HF.MD.PADM.. | 10.2 | | | | HF.PS. SNT1.U.24V.1A | 10.8 | 1x | | |
| | | | 696-850 | GAK.945-1 | 3.1 | FSF | 10.16 | GK = 260 | SBA.K... | 11.1 | 1x | | |
| | | | 851-1100 | GAK.1100-1 | 3.1 | FSF | 10.16 | GK = 375 | SBA.K... | 11.1 | 1x | | |
| | | | 1101-1325 | GAK.1325-1 | 3.1 | FSF | 10.16 | GK = 550 | SBA.K... | 11.1 | 1x | | |
| | | | 1326-1525 | GAK.1550-1 | 3.1 | FSF | 10.16 | GK = 550 | SBA.K... | 11.1 | 1x | | |
| | | | 1526-1775 | GAK.1775-2 | 3.1 | FSF | 10.16 | GK = 550 | SBA.K... | 11.1 | 2x | | |
| | | | 1776-2000 | GAK.2000-2 | 3.1 | FSF | 10.16 | GK = 1050 | SBA.K... | 11.1 | 2x | | |
| | | | 2001-2225 | GAK.2225-2 | 3.1 | FSF | 10.16 | GK = 1050 | SBA.K... | 11.1 | 2x | | |
|  | 461-1475 | 696-2225 | E1 | 4.1 | | | | | SBS.K.PAD... | 11.7 | 1x | | |
|  | 461-600 | 696-2225 | OS1.PA.600 | 5.3 | | | | | | | | | |
| | 601-775 | | OS2.800 | 5.3 | | | | | | | | | |
| | 776-1025 | | OS2.1025-1 | 5.3 | | | | | | SBA.K... | 11.1 | 1x | |
| | 1026-1250 | | OS2.1250-1 | 5.3 | | | | | | SBA.K... | 11.1 | 1x | |
| | 1251-1475 | | OS2.1475-1 | 5.3 | | | | | | SBA.K... | 11.1 | 1x | |
|  | 461-600 | 696-2225 | E3 | 4.3 | SL.C... | 7.1 | SC1.PAD... | 99 | SBA.K... | 11.1 | 1x | | |
| | 601-1475 | | E2 | 4.2 | SL.C... | 7.1 | SC2.PAD... | 7.3 | SBA.K... | 11.1 | 1x | | |
|  | 461-1475 | | 696-750 | MK.150-1 | 9.8 | | | | SBS.K.PAD... | 11.7 | 1x | | |
| | | | 751-1000 | MK.150-1 | 9.8 | KUE-T1 | 10.4 | | SBS.K.PAD... | 11.7 | 1x | | |
| | | | 1001-1250 | M.250-1 | 9.2 | KUE-T1 | 10.4 | MK.PA.250-1 | 9.7 | SBA.K... SBS.K.PAD... | 11.1 11.7 | 1x 1x | |
| | | | 1251-1500 | M.500-1 | 9.2 | KUE-T1 | 10.4 | MK.PA.250-1 | 9.7 | SBA.K... SBS.K.PAD... | 11.1 11.7 | 1x 1x | |
| | | | 1501-1750 | M.750-1 | 9.2 | KUE-T1 | 10.4 | MK.PA.250-1 | 9.7 | SBA.K... SBS.K.PAD... | 11.1 11.7 | 1x 1x | |
| | | | 1751-2000 | KUE-T1 | 10.4 | MK.500-1 | 9.1 | MK.PA.250-1 | 9.7 | SBA.K... SBS.K.PAD... | 11.1 11.7 | 2x 1x | |
| | | | | M.500-1 | 9.2 | | | | | | | | |
| | | | 2001-2225 | KUE-T1 | 10.4 | MK.500-1 | 9.1 | MK.PA.250-1 | 9.7 | SBA.K... SBS.K.PAD... | 11.1 11.7 | 3x 1x | |
| | | | MK.500-1 | 9.1 | M.250-1 | 9.2 | | | | | | | |
|  | 461-1475 | 696-2225 | FL.C.PADM... | 6.1 | EL.CS... | 6.3 | S.FL.C-W... | 6.9 | SBS.K.PAD... | 11.7 | 1x | | |
|  | 461-710 | 696-2225 | KE SL | 9.3 | AL.M... | 10.14 | | | | | | | |
| | 711-960 | | KE SL | 9.3 | AL.M... | 10.14 | MK.250-1 | 9.1 | SBA.K... | 11.1 | 1x | | |
| | 961-1210 | | KE SL | 9.3 | AL.M... | 10.14 | MK.500-1 | 9.1 | SBA.K... | 11.1 | 1x | | |
| | 1211-1460 | | KE SL | 9.3 | AL.M... | 10.14 | MK.750-1 | 9.1 | SBA.K... | 11.1 | 1x | | |
| | 1461-1475 | | KE SL | 9.3 | AL.M... | 10.14 | MK.500-1 | 9.1 | SBA.K... | 11.1 | 2x | | |
| | | | MK.500-1 | 9.1 | | | | | | | | | |
|  | 461-1475 | 696-2225 | E1 | 4.1 | | | | | SBS.K.PAD... | 11.7 | 1x | | |

Turn fitting system - central handle position

Basic equipment
activPilot Comfort PADM

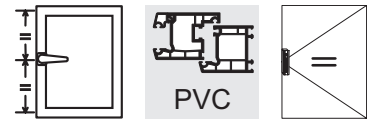

2

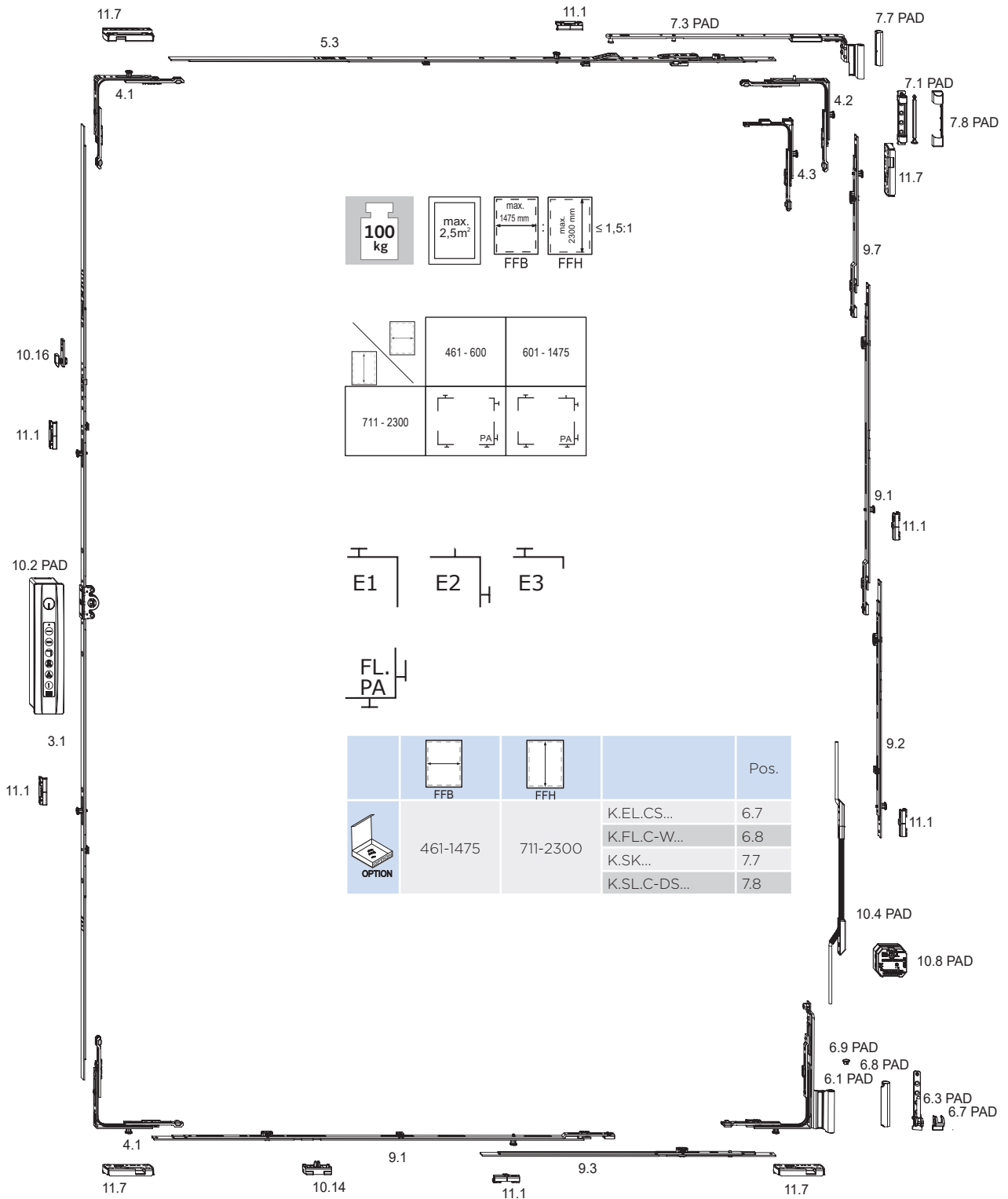

Note: You will find the components marked PAD on the following pages. All other parts can be found in the activPilot Comfort PADK section.

For small sash heights it is important to use a surface-mounted cable transition!

The shown distance between locking points is 800 mm.

The locking distances must be agreed with the system provider.

Turn fitting system - central handle position

Basic equipment

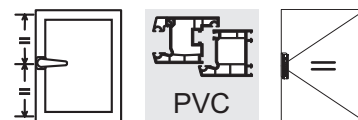

| | | | | Pos. | | Pos. | | Pos. | | Pos. | | |
|--|-----------|-----------|--------------|------|----------|-------|-------------|------|--------------------------|--------------|----------|--|
| | 461-1475 | 711-2300 | HF.MD.PADM.. | 10.2 | | | | | HF.PS. SNT1.U.24V.1A | 10.8 | 1x | |
| | | 711-980 | GAM.1050-1 | 3.1 | FSF | 10.16 | | | SBA.K... | 11.1 | 1x | |
| | | 981-1400 | GAM.1400-1 | 3.1 | FSF | 10.16 | | | SBA.K... | 11.1 | 1x | |
| | | 1401-1800 | GAM.1800-2 | 3.1 | FSF | 10.16 | | | SBA.K... | 11.1 | 2x | |
| | | 1801-2300 | GAM.2300-3 | 3.1 | FSF | 10.16 | | | SBA.K... | 11.1 | 3x | |
| | 461-1475 | 711-2300 | E1 | 4.1 | | | | | SBS.K.PAD... | 11.7 | 1x | |
| | 461-600 | 711-2300 | OS1.PA.600 | 5.3 | | | | | | | | |
| | 601-775 | | OS2.800 | 5.3 | | | | | | | | |
| | 776-1025 | | OS2.1025-1 | 5.3 | | | | | SBA.K... | 11.1 | 1x | |
| | 1026-1250 | | OS2.1250-1 | 5.3 | | | | | SBA.K... | 11.1 | 1x | |
| | 1251-1475 | | OS2.1475-1 | 5.3 | | | | | SBA.K... | 11.1 | 1x | |
| | 461-600 | 711-2300 | E3 | 4.3 | SL.C... | 7.1 | SC1.PAD.... | 99 | SBA.K... | 11.1 | 1x | |
| | 601-1475 | | E2 | 4.2 | SL.C... | 7.1 | SC2.PAD.... | 7.3 | SBA.K... | 11.1 | 1x | |
| | 461-1475 | 711-750 | MK.150-1 | 9.8 | | | | | SBS.K.PAD... | 11.7 | 1x | |
| | | 751-1000 | MK.150-1 | 9.8 | KUE-T1 | 10.4 | | | SBS.K.PAD... | 11.7 | 1x | |
| | | 1001-1250 | M.250-1 | 9.2 | KUE-T1 | 10.4 | MK.PA.250-1 | 9.7 | SBA.K... SBS.K.PAD... | 11.1 11.7 | 1x 1x | |
| | | 1251-1500 | M.500-1 | 9.2 | KUE-T1 | 10.4 | MK.PA.250-1 | 9.7 | SBA.K... SBS.K.PAD... | 11.1 11.7 | 1x 1x | |
| | | 1501-1750 | M.750-1 | 9.2 | KUE-T1 | 10.4 | MK.PA.250-1 | 9.7 | SBA.K... SBS.K.PAD... | 11.1 11.7 | 1x 1x | |
| | | 1751-2000 | KUE-T1 | 10.4 | MK.500-1 | 9.1 | MK.PA.250-1 | 9.7 | SBA.K... SBS.K.PAD... | 11.1 11.7 | 2x 1x | |
| | | | M.500-1 | 9.2 | | | | | | | | |
| | | 2001-2250 | KUE-T1 | 10.4 | MK.500-1 | 9.1 | MK.PA.250-1 | 9.7 | SBA.K... SBS.K.PAD... | 11.1 11.7 | 3x 1x | |
| | | | MK.500-1 | 9.1 | M.250-1 | 9.2 | | | | | | |
| | | 2251-2300 | KUE-T1 | 10.4 | MK.500-1 | 9.1 | MK.PA.250-1 | 9.7 | SBA.K... SBS.K.PAD... | 11.1 11.7 | 3x 1x | |
| | MK.500-1 | 9.1 | M.500-1 | 9.2 | | | | | | | | |
| | 461-1475 | 711-2300 | FL.C.PADM... | 6.1 | EL.CS... | 6.3 | S.FL.C-W... | 6.9 | SBS.K.PAD... | 11.7 | 1x | |
| | 461-710 | 711-2300 | KE SL | 9.3 | AL.M... | 10.14 | | | | | | |
| | 711-960 | | KE SL | 9.3 | AL.M... | 10.14 | MK.250-1 | 9.1 | SBA.K... | 11.1 | 1x | |
| | 961-1210 | | KE SL | 9.3 | AL.M... | 10.14 | MK.500-1 | 9.1 | SBA.K... | 11.1 | 1x | |
| | 1211-1460 | | KE SL | 9.3 | AL.M... | 10.14 | MK.750-1 | 9.1 | SBA.K... | 11.1 | 1x | |
| | 1461-1475 | | KE SL | 9.3 | AL.M... | 10.14 | MK.500-1 | 9.1 | SBA.K... | 11.1 | 2x | |
| | MK.500-1 | 9.1 | | | | | | | | | | |
| | 461-1475 | 711-2300 | E1 | 4.1 | | | | | SBS.K.PAD... | 11.7 | 1x | |

Turn fitting system - constant handle position

Suitable for burglary-resistant windows RC2 / RC2 N
activPilot Comfort PADM

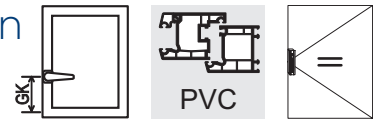

2

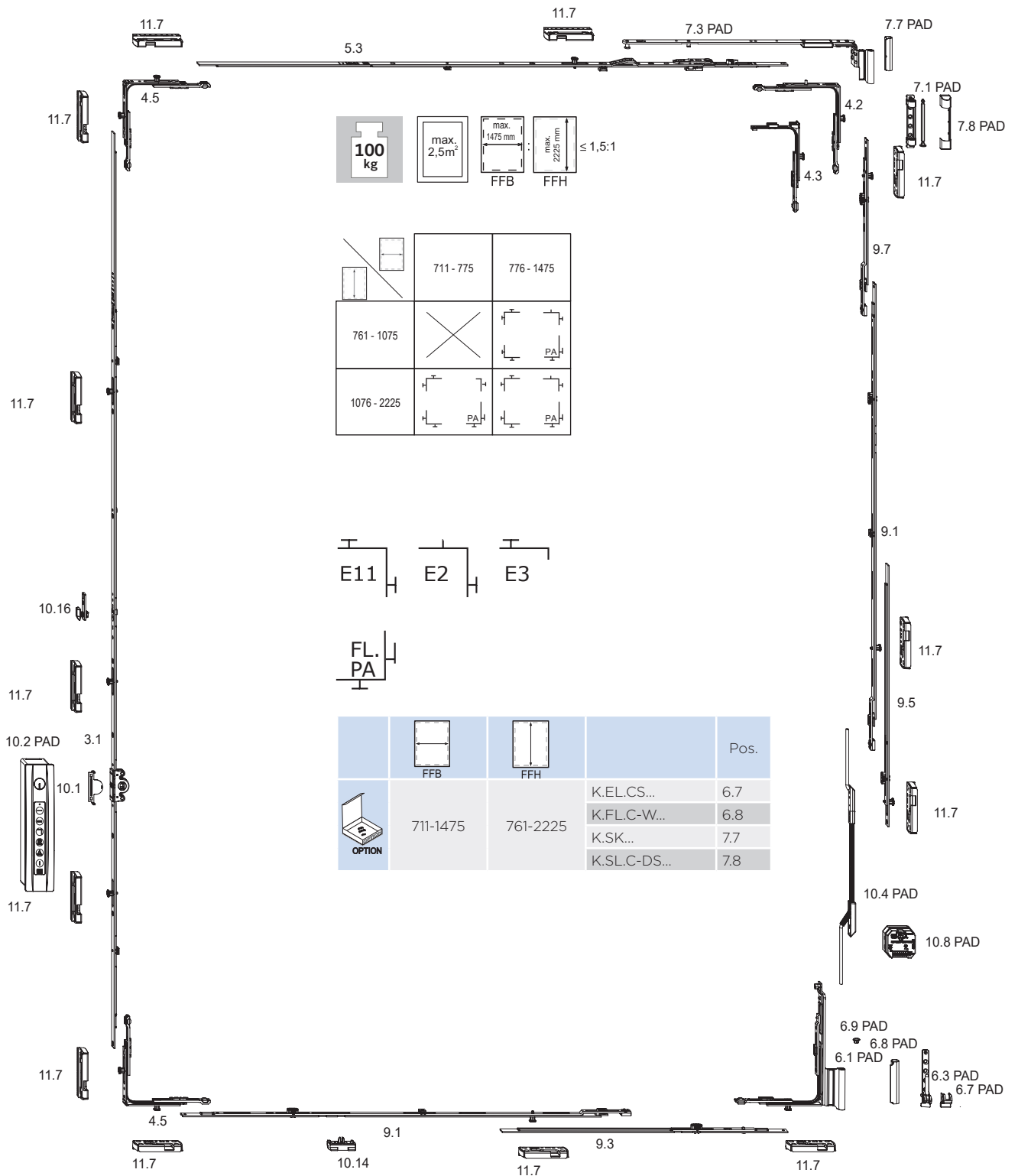

Note: You will find the components marked PAD on the following pages. All other parts can be found in the activPilot Comfort PADK section.

For small sash heights it is important to use a surface-mounted cable transition!









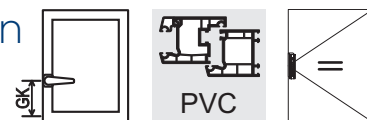

The shown distance between locking points is 800 mm.

The locking distances must be agreed with the system provider.

Turn fitting system - constant handle position

Suitable for burglary-resistant windows RC2 / RC2 N



| |  |  | | Pos. | | Pos. | | Pos. | | Pos. | |
|---|--|---|------------------------|------------|--------------|-------|--------------|------|-------------------------|------|----|
|  |  711-1475 | 761-2225 | AB.G.D.15,5 | 10.1 | HF.MD.PADM.. | 10.2 | | | HF.PS. SNT1.U.24V.1A | 10.8 | 1x |
| | 776-1475 | 761-850 | GAK.945-1 | 3.1 | FSF | 10.16 | | | SBS.K.PAD... | 11.7 | 1x |
| | | 851-1075 | GAK.1100-1 | 3.1 | FSF | 10.16 | | | SBS.K.PAD... | 11.7 | 1x |
| | 711-1475 | 1076-1325 | GAK.1325-2 | 3.1 | FSF | 10.16 | | | SBS.K.PAD... | 11.7 | 2x |
| | | 1326-1525 | GAK.1550-2 | 3.1 | FSF | 10.16 | | | SBS.K.PAD... | 11.7 | 2x |
| | | 1526-1775 | GAK.1775-3 | 3.1 | FSF | 10.16 | | | SBS.K.PAD... | 11.7 | 3x |
| | | 1776-2000 | GAK.2000-4 | 3.1 | FSF | 10.16 | | | SBS.K.PAD... | 11.7 | 4x |
| 2001-2225 | GAK.2225-4 | 3.1 | FSF | 10.16 | | | SBS.K.PAD... | 11.7 | 4x | | |
|  | 711-1475 | 1076-2225 | E11 | 4.5 | | | | | SBS.K.PAD... | 11.7 | 2x |
| | 776-1475 | 761-1075 | E11 | 4.5 | | | | | SBS.K.PAD... | 11.7 | 2x |
|  | 711-775 | 1076-2225 | OS1.PA.600 | 5.3 | MK.250-1 | 9.1 | | | SBS.K.PAD... | 11.7 | 1x |
| | 776-1025 | | OS2.1025-1 | 5.3 | | | | | SBS.K.PAD... | 11.7 | 1x |
| | 1026-1250 | 761-2225 | OS2.1250-1 | 5.3 | | | | | SBS.K.PAD... | 11.7 | 1x |
| | 1251-1475 | | OS2.1250-1 | 5.3 | MK.250-1 | 9.1 | | | SBS.K.PAD... | 11.7 | 2x |
|  | 711-775 | 1076-2225 | E3 | 4.3 | SL.C... | 7.1 | SC1.PAD.... | 7.3 | | | |
| | 776-1475 | 761-2225 | E2 | 4.2 | SL.C... | 7.1 | SC2.PAD.... | 7.3 | | | |
|  | 776-1475 | 761-1010 | MK.PA.250-1 | 9.7 | V.AK.450-1 | 9.5 | | | SBS.K.PAD... | 11.7 | 2x |
| | | 1011-1020 | MK.250-1 | 9.1 | MK.PA.250-1 | 9.7 | V.AK.450-1 | 9.5 | SBS.K.PAD... | 11.7 | 3x |
| | | 1021-1075 | MK.PA.250-1 | 9.7 | KUE-T1 | 10.4 | V.AK.450-1 | 9.5 | SBS.K.PAD... | 11.7 | 2x |
| | 711-1475 | 1076-1270 | MK.PA.250-1 | 9.7 | KUE-T1 | 10.4 | V.AK.450-1 | 9.5 | SBS.K.PAD... | 11.7 | 2x |
| | | 1271-1520 | MK.250-1 V.AK.450-1 | 9.1 9.5 | KUE-T1 | 10.4 | MK.PA.250-1 | 9.7 | SBS.K.PAD... | 11.7 | 3x |
| | | 1521-1770 | MK.500-1 V.AK.450-1 | 9.1 9.5 | KUE-T1 | 10.4 | MK.PA.250-1 | 9.7 | SBS.K.PAD... | 11.7 | 3x |
| | | 1771-2020 | MK.750-1 V.AK.450-1 | 9.1 9.5 | KUE-T1 | 10.4 | MK.PA.250-1 | 9.7 | SBS.K.PAD... | 11.7 | 3x |
| 2021-2225 | KUE-T1 MK.500-1 | 10.4 9.1 | MK.500-1 V.AK.450-1 | 9.1 9.5 | MK.PA.250-1 | 9.7 | SBS.K.PAD... | 11.7 | 4x | | |
|  | 776-1475 | 761-1075 | FL.C.PADM... | 6.1 | EL.CS... | 6.3 | S.FL.C-W... | 6.9 | SBS.K.PAD... | 11.7 | 1x |
| | 711-1475 | 1076-2225 | FL.C.PADM... | 6.1 | EL.CS... | 6.3 | S.FL.C-W... | 6.9 | SBS.K.PAD... | 11.7 | 1x |
|  | 711-960 | 1076-2225 | KE SL | 9.3 | AL.M... | 10.14 | MK.250-1 | 9.1 | SBS.K.PAD... | 11.7 | 1x |
| | 776-960 | 761-1075 | KE SL | 9.3 | AL.M... | 10.14 | MK.250-1 | 9.1 | SBS.K.PAD... | 11.7 | 1x |
| | 961-1210 | 761-2225 | KE SL | 9.3 | AL.M... | 10.14 | MK.500-1 | 9.1 | SBS.K.PAD... | 11.7 | 1x |
| | 1211-1460 | | KE SL | 9.3 | AL.M... | 10.14 | MK.750-1 | 9.1 | SBS.K.PAD... | 11.7 | 1x |
| | 1461-1475 | | KE SL MK.500-1 | 9.3 9.1 | AL.M... | 10.14 | MK.500-1 | 9.1 | SBS.K.PAD... | 11.7 | 2x |
|  | 711-1475 | 1076-2225 | E11 | 4.5 | | | | | SBS.K.PAD... | 11.7 | 2x |
| | 776-1475 | 761-1075 | E11 | 4.5 | | | | | SBS.K.PAD... | 11.7 | 2x |

 marks a line with items that are always used, regardless of size

Turn fitting system - central handle position

Suitable for burglary-resistant windows RC2 / RC2 N
activPilot Comfort PADM

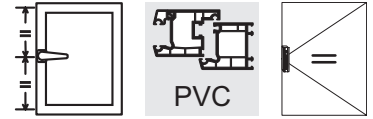

2

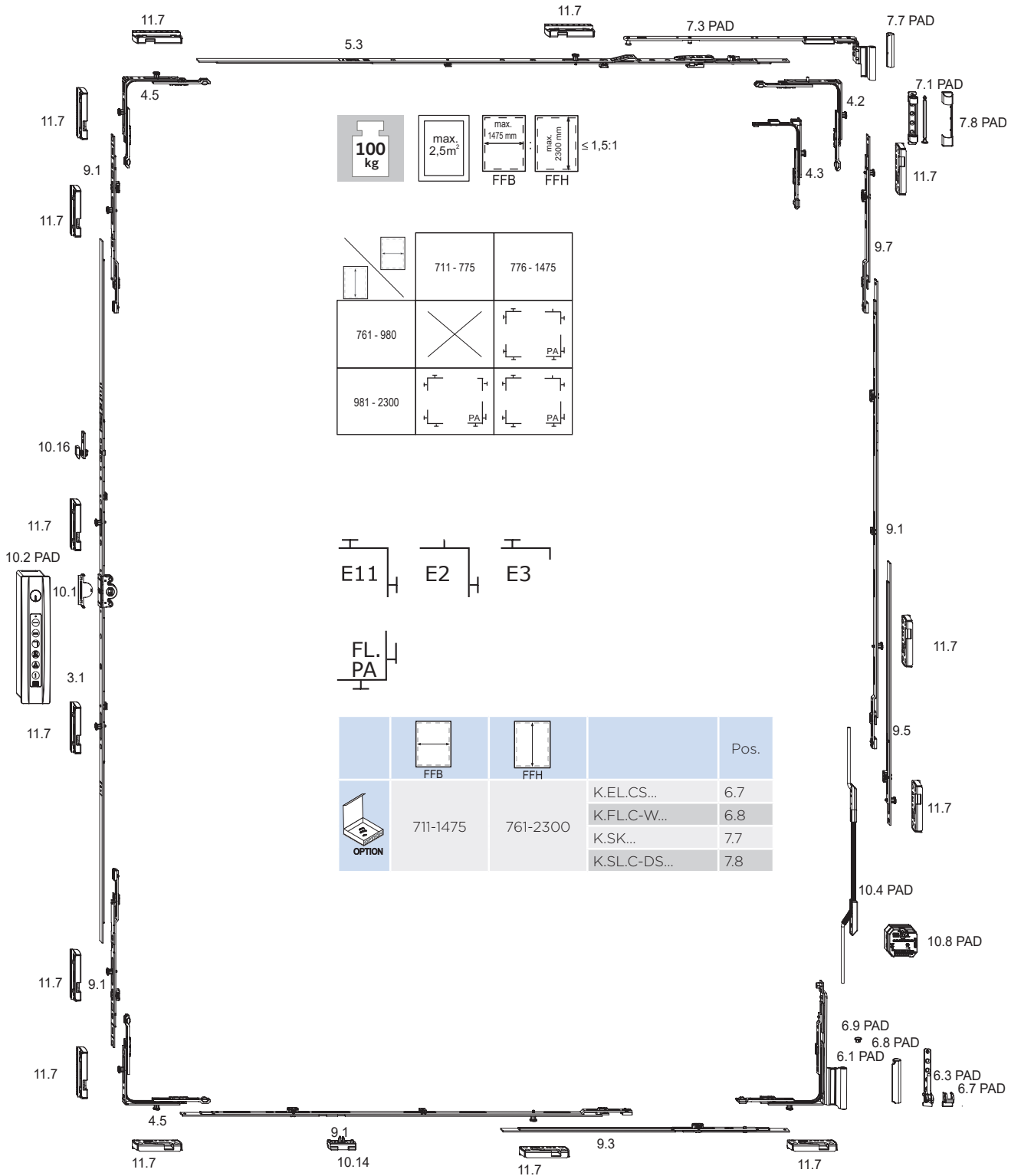

Note: You will find the components marked PAD on the following pages. All other parts can be found in the activPilot Comfort PADK section.

For small sash heights it is important to use a surface-mounted cable transition!









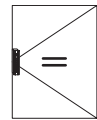
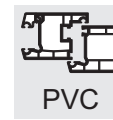
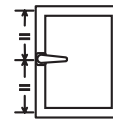

The shown distance between locking points is 800 mm.

The locking distances must be agreed with the system provider.

Turn fitting system - central handle position

Suitable for burglary-resistant windows RC2 / RC2 N



| |  |  | | Pos. | | Pos. | | Pos. | | Pos. | |
|---|---|---|--------------|------------|--------------|----------|--------------|--------------|-------------------------|------|----|
|  | i 711-1475 | 761-2300 | AB.G.D.15,5 | 10.1 | HF.MD.PADM.. | 10.2 | | | HF.PS. SNT1.U.24V.1A | 10.8 | 1x |
| | 776-1475 | 761-980 | GAM.1050-1 | 3.1 | FSF | 10.16 | | | SBS.K.PAD... | 11.7 | 1x |
| | 711-1475 | 981-1300 | GAM.1400-2 | 3.1 | FSF | 10.16 | | | SBS.K.PAD... | 11.7 | 2x |
| | | 1301-1600 | GAM.1800-2 | 3.1 | FSF | 10.16 | | | SBS.K.PAD... | 11.7 | 2x |
| | 711-775 | 1601-1800 | GAM.1400-2 | 3.1 | FSF | 10.16 | MK.250-1 | 9.1 | SBS.K.PAD... | 11.7 | 4x |
| | | | MK.250-1 | 9.1 | | | | | | | |
| | 776-1475 | 1601-1800 | MK.250-1 | 9.1 | GAM.1400-2 | 3.1 | FSF | 10.16 | SBS.K.PAD... | 11.7 | 4x |
| | | | MK.250-1 | 9.1 | | | | | | | |
| 711-1475 | 1801-1900 | GAM.2300-3 | 3.1 | FSF | 10.16 | | | SBS.K.PAD... | 11.7 | 3x | |
| 711-775 | 1901-2300 | GAM.1400-2 | 3.1 | FSF | 10.16 | MK.500-1 | 9.1 | SBS.K.PAD... | 11.7 | 4x | |
| | | MK.500-1 | 9.1 | | | | | | | | |
| 776-1475 | 1901-2300 | MK.500-1 | 9.1 | GAM.1400-2 | 3.1 | FSF | 10.16 | SBS.K.PAD... | 11.7 | 4x | |
| | | MK.500-1 | 9.1 | | | | | | | | |
|  | 711-1475 | 981-2300 | E11 | 4.5 | | | | | SBS.K.PAD... | 11.7 | 2x |
| | 776-1475 | 761-980 | E11 | 4.5 | | | | | SBS.K.PAD... | 11.7 | 2x |
|  | 711-775 | 981-2300 | OS1.PA.600 | 5.3 | MK.250-1 | 9.1 | | | SBS.K.PAD... | 11.7 | 1x |
| | 776-1025 | 761-2300 | OS2.1025-1 | 5.3 | | | | | SBS.K.PAD... | 11.7 | 1x |
| | 1026-1250 | | OS2.1250-1 | 5.3 | | | | | SBS.K.PAD... | 11.7 | 1x |
| | 1251-1475 | | OS2.1250-1 | 5.3 | MK.250-1 | 9.1 | | | SBS.K.PAD... | 11.7 | 2x |
|  | 711-775 | 981-2300 | E3 | 4.3 | SL.C... | 7.1 | SC1.PAD... | 7.3 | | | |
| | 776-1475 | 761-2300 | E2 | 4.2 | SL.C... | 7.1 | SC2.PAD... | 7.3 | | | |
|  | 776-1475 | 761-980 | MK.PA.250-1 | 9.7 | V.AK.450-1 | 9.5 | | | SBS.K.PAD... | 11.7 | 2x |
| | | 981-1010 | MK.PA.250-1 | 9.7 | V.AK.450-1 | 9.5 | | | SBS.K.PAD... | 11.7 | 2x |
| | | 1011-1020 | MK.250-1 | 9.1 | MK.PA.250-1 | 9.7 | V.AK.450-1 | 9.5 | SBS.K.PAD... | 11.7 | 3x |
| | | 1021-1270 | MK.PA.250-1 | 9.7 | KUE-T1 | 10.4 | V.AK.450-1 | 9.5 | SBS.K.PAD... | 11.7 | 2x |
| | | 1271-1520 | MK.250-1 | 9.1 | KUE-T1 | 10.4 | MK.PA.250-1 | 9.7 | SBS.K.PAD... | 11.7 | 3x |
| | | | V.AK.450-1 | 9.5 | | | | | | | |
| | | 1521-1770 | MK.500-1 | 9.1 | KUE-T1 | 10.4 | MK.PA.250-1 | 9.7 | SBS.K.PAD... | 11.7 | 3x |
| | | | V.AK.450-1 | 9.5 | | | | | | | |
| | | 1771-2020 | MK.750-1 | 9.1 | KUE-T1 | 10.4 | MK.PA.250-1 | 9.7 | SBS.K.PAD... | 11.7 | 3x |
| V.AK.450-1 | 9.5 | | | | | | | | | | |
| 2021-2270 | KUE-T1 | 10.4 | MK.500-1 | 9.1 | MK.PA.250-1 | 9.7 | SBS.K.PAD... | 11.7 | 4x | | |
| | MK.500-1 | 9.1 | V.AK.450-1 | 9.5 | | | | | | | |
| 2271-2300 | KUE-T1 | 10.4 | MK.500-1 | 9.1 | MK.PA.250-1 | 9.7 | SBS.K.PAD... | 11.7 | 5x | | |
| | MK.500-1 | 9.1 | MK.250-1 | 9.1 | V.AK.450-1 | 9.5 | | | | | |
|  | 776-1475 | 761-980 | FL.C.PADM... | 6.1 | EL.CS... | 6.3 | S.FL.C-W... | 6.9 | SBS.K.PAD... | 11.7 | 1x |
| | 711-1475 | 981-2300 | FL.C.PADM... | 6.1 | EL.CS... | 6.3 | S.FL.C-W... | 6.9 | SBS.K.PAD... | 11.7 | 1x |
|  | 711-960 | 981-2300 | KE SL | 9.3 | AL.M... | 10.14 | MK.250-1 | 9.1 | SBS.K.PAD... | 11.7 | 1x |
| | 776-960 | 761-980 | KE SL | 9.3 | AL.M... | 10.14 | MK.250-1 | 9.1 | SBS.K.PAD... | 11.7 | 1x |
| | 961-1210 | 761-2300 | KE SL | 9.3 | AL.M... | 10.14 | MK.500-1 | 9.1 | SBS.K.PAD... | 11.7 | 1x |
| | 1211-1460 | | KE SL | 9.3 | AL.M... | 10.14 | MK.750-1 | 9.1 | SBS.K.PAD... | 11.7 | 1x |
| | 1461-1475 | | KE SL | 9.3 | AL.M... | 10.14 | MK.500-1 | 9.1 | SBS.K.PAD... | 11.7 | 2x |
| MK.500-1 | | 9.1 | | | | | | | | | |
|  | 711-1475 | 981-2300 | E11 | 4.5 | | | | | SBS.K.PAD... | 11.7 | 2x |
| | 776-1475 | 761-980 | E11 | 4.5 | | | | | SBS.K.PAD... | 11.7 | 2x |

i marks a line with items that are always used, regardless of size

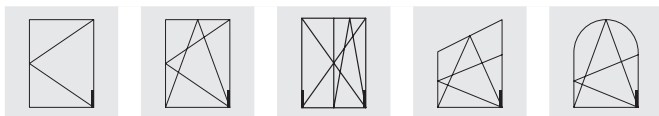
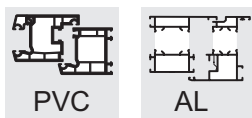

Corner hinges EL.CS

6

- Used in combination with overlap sash hinges FL.C or rebate sash hinges FL.C-W / FL.C.PA
- Large support area underneath the tilt axis
- For drilling instructions see group 15, installation drawings
- For sash weight see overview of articles
- Side adjustment ± 2 mm

Corner hinge cover K.EL.CS

- See separate product page

EL.CS

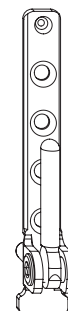

K.EL.CS



| Item designation | Item no. |  | Max. sash weight (kg) | VPA1 Pcs/type | VPA2 Pcs/type |
|------------------|----------|---|-----------------------|------------------|------------------|
| EL.CS.3-3-3 | 5064222 | 4 | 80 | 300 KK | 2400 EK |
| EL.CS.3-3-3.BR | 5064225 | 4 | 80 | 300 KK | 2400 EK |
| EL.CS.3-3-3.F9 | 5064224 | 4 | 80 | 300 KK | 2400 EK |
| EL.CS.3-3-3.WS | 5064223 | 4 | 80 | 300 KK | 2400 EK |
| EL.CS.6-3-3 | 5064226 | 4 | 100 | 300 KK | 2400 EK |
| EL.CS.6-3-3.BR | 5064229 | 4 | 100 | 300 KK | 2400 EK |
| EL.CS.6-3-3.F9 | 5064228 | 4 | 100 | 300 KK | 2400 EK |
| EL.CS.6-3-3.WS | 5064227 | 4 | 100 | 300 KK | 2400 EK |
| EL.CS.6-3-10 | 5064230 | 4 | 100 | 300 KK | 2400 EK |
| EL.CS.6-3-10.BR | 5064233 | 4 | 100 | 300 KK | 2400 EK |
| EL.CS.6-3-10.F9 | 5064232 | 4 | 100 | 300 KK | 2400 EK |
| EL.CS.6-3-10.WS | 5064231 | 4 | 100 | 300 KK | 2400 EK |
| EL.CS.6-3-22 | 5064234 | 4 | 130/150 | 300 KK | 2400 EK |
| EL.CS.6-3-22.BR | 5064237 | 4 | 130/150 | 300 KK | 2400 EK |
| EL.CS.6-3-22.F9 | 5064236 | 4 | 130/150 | 300 KK | 2400 EK |
| EL.CS.6-3-22.WS | 5064235 | 4 | 130/150 | 300 KK | 2400 EK |
| EL.CS.6-10-10.WS | 5064238 | 4 | 100 | 300 KK | 2400 EK |
| EL.CS.6-22-3 | 5064239 | 4 | 130/150 | 300 KK | 2400 EK |
| EL.CS.6-22-3.BR | 5064241 | 4 | 130/150 | 300 KK | 2400 EK |
| EL.CS.6-22-3.WS | 5064240 | 4 | 130/150 | 300 KK | 2400 EK |

WS = white; BR = brown, F9 = titanium coloured

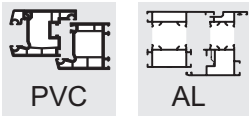

Corner hinges EL.CS-W

- Used in combination with rebate sash hinges FL.C-W / FL.C.PA
- Large support area underneath the tilt axis
- For drilling instructions see group 15, installation drawings
- Sash weight see Table of articles
- Side adjustment ± 2 mm
- With bolt support (max. parallel position of the bolt towards the corner hinge plate) avoids unintentional contact of the sash hinge roll and the corner hinge plate

- Recommendation for use: unfavourable sash formats, e. g.
- FFB > 1000 mm
- Sash rebate width: FFH > 1:1

Corner hinge cover K.EL.CS

- See separate product page

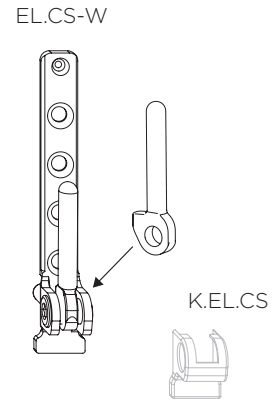

| Item designation | Item no. |  | Max. sash weight (kg) | VPA1 Pcs/type | VPA2 Pcs/type |
|--------------------|----------|---|-----------------------|------------------|------------------|
| EL.CS-W.6-3-3 | 5064244 | 4 | 100 | 300 KK | 2400 EK |
| EL.CS-W.6-3-3.F9 | 5064246 | 4 | 100 | 300 KK | 2400 EK |
| EL.CS-W.6-3-3.WS | 5064245 | 4 | 100 | 300 KK | 2400 EK |
| EL.CS-W.6-3-10 | 5064247 | 4 | 100 | 300 KK | 2400 EK |
| EL.CS-W.6-3-10.F9 | 5064249 | 4 | 100 | 300 KK | 2400 EK |
| EL.CS-W.6-3-10.WS | 5064248 | 4 | 100 | 300 KK | 2400 EK |
| EL.CS-W.6-3-22 | 5064250 | 4 | 130/150 | 300 KK | 2400 EK |
| EL.CS-W.6-3-22.F9 | 5064252 | 4 | 130/150 | 300 KK | 2400 EK |
| EL.CS-W.6-3-22.WS | 5064251 | 4 | 130/150 | 300 KK | 2400 EK |
| EL.CS-W.6-10-10.WS | 5064253 | 4 | 100 | 300 KK | 2400 EK |
| EL.CS-W.6-22-3 | 5064254 | 4 | 130/150 | 300 KK | 2400 EK |
| EL.CS-W.6-22-3.WS | 5064255 | 4 | 130/150 | 300 KK | 2400 EK |

WS = white; BR = brown, F9 = titanium coloured

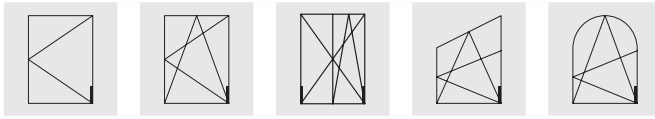
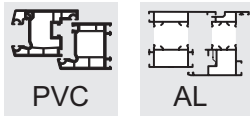

Corner hinge cap K.EL.CS

6

- Cover for narrow corner hinges EL.CS...
- For visual cover of the bottom area of the corner hinge
- Can be used left and right hand
- Available in different colours

EL.CS



K.EL.CS



| Item designation | Item no. | VPA1 Pcs/type | VPA2 Pcs/type | VPA3 Pcs/type |
|------------------|----------|------------------|------------------|------------------|
| K.EL.CS.BR | 5065117 | 100 BL | 1000 KK | 8000 EK |
| K.EL.CS.BZ-CN | 5065504 | 100 BL | 1000 KK | 8000 EK |
| K.EL.CS.BZ-RB | 5065508 | 100 BL | 1000 KK | 8000 EK |
| K.EL.CS.CW | 5065509 | 100 BL | 1000 KK | 8000 EK |
| K.EL.CS.F1 | 5065521 | 100 BL | 1000 KK | 8000 EK |
| K.EL.CS.F1-ELOX | 5065522 | 100 BL | 1000 KK | 8000 EK |
| K.EL.CS.F3 | 5065524 | 100 BL | 1000 KK | 8000 EK |
| K.EL.CS.F3-MG | 5065525 | 100 BL | 1000 KK | 8000 EK |
| K.EL.CS.F9 | 5065527 | 100 BL | 1000 KK | 8000 EK |
| K.EL.CS.LBR | 5065529 | 100 BL | 1000 KK | 8000 EK |
| K.EL.CS.LGR | 5065536 | 100 BL | 1000 KK | 8000 EK |
| K.EL.CS.PW | 5065537 | 100 BL | 1000 KK | 8000 EK |
| K.EL.CS.SW | 5065538 | 100 BL | 1000 KK | 8000 EK |
| K.EL.CS.UN77078 | 5065539 | 100 BL | 1000 KK | 8000 EK |
| K.EL.CS.WS | 5065119 | 100 BL | 1000 KK | 8000 EK |

AGR = anthracite grey, BR = brown, BZ-AM = bronze - antique brass, BZ-RB = bronze - red brown, BZ-CU = bronze coppery, CW = cream white, EV1 = anodised silver, F1 = silver colour, F1-elox = sim. to F1 anodised silver, F3 = gold colour, F3-MG = gold mat, F9 = titanium-coloured, LBR = clay brown, PW = pearl white, SG = silver grey, SGB = grey, SGR = dust grey, SL = silver look (galvanised), SW = deep black, WS = white

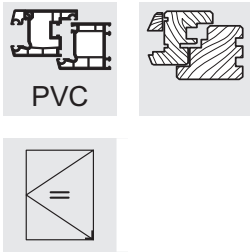

Sash hinges FL.C.PADM.20-13

- Height adjustment ± 3 mm
- Central position is the factory default
- In combination with corner hinges EL.CS / EL.CS-W / EL.HC.PA
- Parallel action possible via the control curve
- Operating sequence: locked position – parallel action – turn position

Sash hinge cover K.FL.C-W

- Available in different colours

Sash hinge plug S.FL.C-W

- Can be used left and right hand
- Dirt protection for height adjustment device
- Available in different colours

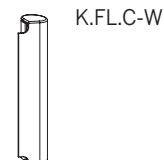
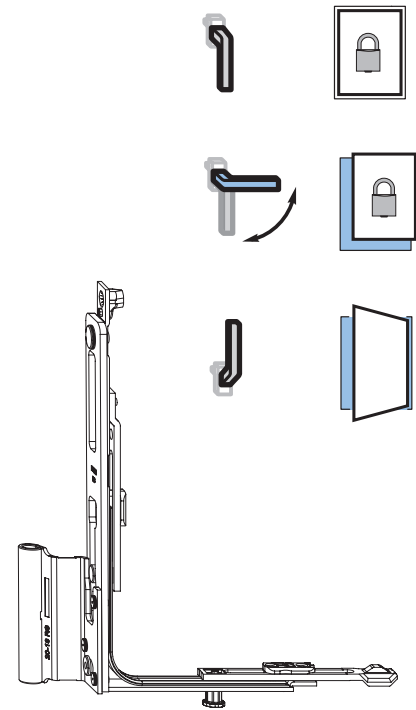

| Item designation | Item no. |  | Max. sash weight (kg) | Overlap | Groove centre position | VPA1 Pcs/type | VPA2 Pcs/type | VPA3 Pcs/type |
|-----------------------|----------|---|-----------------------|---------|------------------------|---------------|---------------|---------------|
| FL.C.PADM.20-13.LS | 5069188 | 4 | 100 | 20 | 13 | 20 KK | 160 EK | |
| FL.C.PADM.20-13.RS | 5069187 | 4 | 100 | 20 | 13 | 20 KK | 160 EK | |
| FL.C.PADM.20-13.LS.F9 | 5069200 | 4 | 100 | 20 | 13 | 20 KK | 160 EK | |
| FL.C.PADM.20-13.RS.F9 | 5069199 | 4 | 100 | 20 | 13 | 20 KK | 160 EK | |
| FL.C.PADM.20-13.LS.WS | 5069198 | 4 | 100 | 20 | 13 | 20 KK | 160 EK | |
| FL.C.PADM.20-13.RS.WS | 5069197 | 4 | 100 | 20 | 13 | 20 KK | 160 EK | |
| K.FL.C-W.LS.BR | 5065127 | | | | | 100 BL | 300 KK | 2400 EK |
| K.FL.C-W.RS.BR | 5065126 | | | | | 100 BL | 300 KK | 2400 EK |
| K.FL.C-W.LS.BZ-AM | 5065575 | | | | | 100 BL | 300 KK | 2400 EK |
| K.FL.C-W.RS.BZ-AM | 5065574 | | | | | 100 BL | 300 KK | 2400 EK |
| K.FL.C-W.LS.BZ-RB | 5065577 | | | | | 100 BL | 300 KK | 2400 EK |
| K.FL.C-W.RS.BZ-RB | 5065576 | | | | | 100 BL | 300 KK | 2400 EK |
| K.FL.C-W.LS.CW | 5065579 | | | | | 100 BL | 300 KK | 2400 EK |
| K.FL.C-W.RS.CW | 5065578 | | | | | 100 BL | 300 KK | 2400 EK |
| K.FL.C-W.LS.F1 | 5065581 | | | | | 100 BL | 300 KK | 2400 EK |
| K.FL.C-W.RS.F1 | 5065580 | | | | | 100 BL | 300 KK | 2400 EK |
| K.FL.C-W.LS.F1-ELOX | 5065583 | | | | | 100 BL | 300 KK | 2400 EK |
| K.FL.C-W.RS.F1-ELOX | 5065582 | | | | | 100 BL | 300 KK | 2400 EK |
| K.FL.C-W.LS.F3 | 5065603 | | | | | 100 BL | 300 KK | 2400 EK |
| K.FL.C-W.RS.F3 | 5065602 | | | | | 100 BL | 300 KK | 2400 EK |
| K.FL.C-W.LS.F9 | 5065605 | | | | | 100 BL | 300 KK | 2400 EK |
| K.FL.C-W.RS.F9 | 5065604 | | | | | 100 BL | 300 KK | 2400 EK |
| K.FL.C-W.LS.SW | 5065607 | | | | | 100 BL | 300 KK | 2400 EK |
| K.FL.C-W.RS.SW | 5065606 | | | | | 100 BL | 300 KK | 2400 EK |
| K.FL.C-W.LS.WS | 5065129 | | | | | 100 BL | 300 KK | 2400 EK |
| K.FL.C-W.RS.WS | 5065128 | | | | | 100 BL | 300 KK | 2400 EK |
| S.FL.C-W.BR | 5065613 | | | | | 500 BL | 3000 KK | 24000 EK |
| S.FL.C-W.F1 | 5065614 | | | | | 500 BL | 3000 KK | 24000 EK |
| S.FL.C-W.F9 | 5065615 | | | | | 500 BL | 3000 KK | 24000 EK |
| S.FL.C-W.WS | 5065616 | | | | | 500 BL | 3000 KK | 24000 EK |

RS = right, LS = left

WS = white, BR = brown, EV1 = anodised silver, CW = cream white, F9 = titanium coloured, BZ-CU = bronze copper, BZ-RB (F4)= bronze red brown, RAL9007 = colour according to RAL

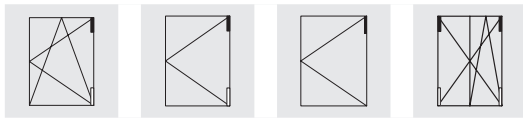
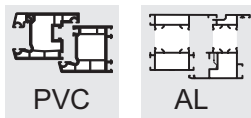

Shear hinge SL.C

- Rolled steel hinge
- Fixing screws are covered by the shear hinge insert.
- Integrated pin-securing device
- Remove shear pin by means of special pulling device
- A small free size of the frame is required.
- For drilling instructions see group 15, installation drawings

7

Shear hinge cover K.SL.C-DS

- See separate product page

Additional plate ZSP.SL.C

- Positioning and screwing above the shear hinge SL.C
- Improves the load transfer of the shear hinge to the frame by increasing the number of screws
- Enables higher traction values acc. to TBDK (e.g. in case of steelless systems)
- Available in different colours
- Covers K.SL.C... cannot be used in this combination.

SL.C

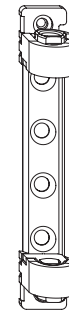

K.SL.C-DS

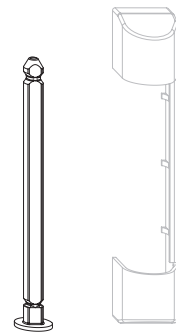

ZSP.SL.C



SL.C

| Item designation | Item no. |  | Max. sash weight (kg) | VPA1 Pcs/type | VPA2 Pcs/type | VPA3 Pcs/type |
|------------------|----------|---|-----------------------|------------------|------------------|------------------|
| SL.C.3-3 | 5081484 | 4 | 80 | 200 KK | 1600 EK | |
| SL.C.3-3.BR | 5081487 | 4 | 80 | 200 KK | 1600 EK | |
| SL.C.3-3.CW | 5081488 | 4 | 80 | 200 KK | 1600 EK | |
| SL.C.3-3.F9 | 5081486 | 4 | 80 | 200 KK | 1600 EK | |
| SL.C.3-3.WS | 5081485 | 4 | 80 | 200 KK | 1600 EK | |
| SL.C.3-6 | 5081489 | 4 | 130/150 | 200 KK | 1600 EK | |
| SL.C.3-6.BR | 5081492 | 4 | 130/150 | 200 KK | 1600 EK | |
| SL.C.3-6.CW | 5081493 | 4 | 130/150 | 200 KK | 1600 EK | |
| SL.C.3-6.F9 | 5081491 | 4 | 130/150 | 200 KK | 1600 EK | |
| SL.C.3-6.WS | 5081490 | 4 | 130/150 | 200 KK | 1600 EK | |
| ZSP.SL.C.WS | 5086827 | 1 | | 100 BL | 2000 KK | 16000 EK |
| ZSP.SL.C.F9 | 5086828 | 1 | | 100 BL | 2000 KK | 16000 EK |
| ZSP.SL.C.CW | 5086829 | 1 | | 100 BL | 2000 KK | 16000 EK |

WS = white, BR = brown, SL = silver, EV1 = anodised silver, F1 = silver colour, F3 = gold colour, BZ-RB = bronze red brown, F9 = titanium coloured, CW = cream white

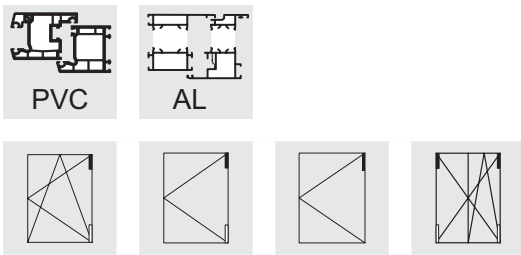

Caps

Shear hinge cover K.SL.C-DS

- Cover for shear hinge SL.C
- Can be used left and right hand

Shear hinge cap K.SK

- Can be used left and right hand
- Available in different colours

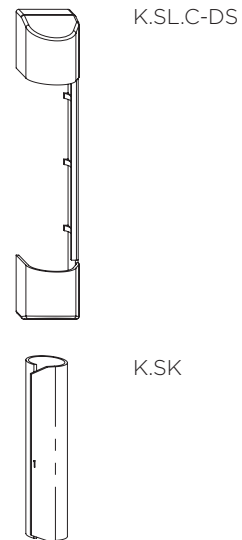

7

| Item designation | Item no. | VPA1 Pcs/type | VPA2 Pcs/type | VPA3 Pcs/type |
|-------------------|----------|------------------|------------------|------------------|
| K.SL.C-DS.BR | 5081091 | 100 BL | 300 KK | 7200 EK |
| K.SL.C-DS.BZ-OPL | 5081099 | 100 BL | 300 KK | 7200 EK |
| K.SL.C-DS.BZ-RB | 5081098 | 100 BL | 300 KK | 7200 EK |
| K.SL.C-DS.CW | 5081096 | 100 BL | 300 KK | 7200 EK |
| K.SL.C-DS.F1 | 5081100 | 100 BL | 300 KK | 7200 EK |
| K.SL.C-DS.F1-ELOX | 5081101 | 100 BL | 300 KK | 7200 EK |
| K.SL.C-DS.F1-OPL | 5081102 | 100 BL | 300 KK | 7200 EK |
| K.SL.C-DS.F3 | 5081103 | 100 BL | 300 KK | 7200 EK |
| K.SL.C-DS.F3-MG | 5081104 | 100 BL | 300 KK | 7200 EK |
| K.SL.C-DS.F9 | 5081092 | 100 BL | 300 KK | 7200 EK |
| K.SL.C-DS.SW | 5081097 | 100 BL | 300 KK | 7200 EK |
| K.SL.C-DS.UN77078 | 5081105 | 100 BL | 300 KK | 7200 EK |
| K.SL.C-DS.WS | 5081090 | 100 BL | 300 KK | 7200 EK |
| K.SK.BR | 4927421 | 100 BL | 600 KK | 14400 EK |
| K.SK.BZ-CN | 5031480 | 100 BL | 300 KK | 2400 EK |
| K.SK.BZ-RB | 4933296 | 100 BL | 600 KK | 4800 EK |
| K.SK.CW | 4927572 | 100 BL | 600 KK | 4800 EK |
| K.SK.F1 | 4928484 | 100 BL | 600 KK | 4800 EK |
| K.SK.F1-ELOX. | 5021124 | 100 BL | 600 K3 | 4800 E3 |
| K.SK.F3 | 4995009 | 100 BL | 600 KK | 4800 EK |
| K.SK.F3 BA | 5034998 | 100 BL | 600 KK | 4800 EK |
| K.SK.F3-MG | 4987480 | 100 BL | 600 KK | 4800 EK |
| K.SK.F9 | 2845293 | 100 BL | 600 KK | 14400 EK |
| K.SK.LBR | 4939036 | 100 BL | 600 KK | 4800 EK |
| K.SK.SL.UN77078 | 4993489 | 100 BL | 600 KK | 4800 EK |
| K.SK.SW | 4939055 | 100 BL | 600 KK | 4800 EK |
| K.SK.WS | 2845285 | 100 BL | 600 KK | 14400 EK |

AGR = anthracite grey, BR = brown, BZ-AM = bronze - antique brass, BZ-RB = bronze - red brown, BZ-CU = bronze coppery, CW = cream white, EV1 = anodised silver, F1 = silver colour, F1-elox = sim. to F1 anodised silver, F3 = gold colour, F3-MG = gold mat, F9 = titanium-coloured, LBR = clay brown, PW = pearl white, SG = silver grey, SGB = grey, SGR = dust grey, SL = silver look (galvanised), SW = deep black, WS = white

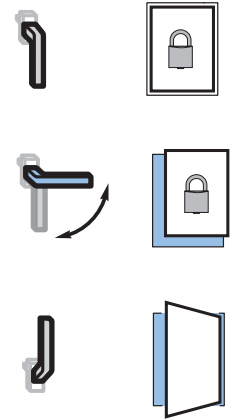
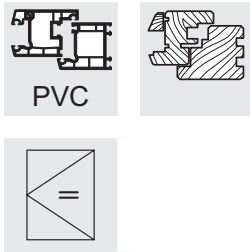

Shears SC ... PAD.20-13

- Suitable for top rods OS1/OS2
- For 20 mm overlap and 13 mm groove centre position
- Adjustment for lifting and lowering the sash (+3.5/-2.0 mm)
- Parallel opening approx. 6 mm
- After assembly the top rod and the shear are firmly attached to one another
- Integrated turn restriction via plastic sleeve in shear hinge
- Sash weight max. 100 kg
- With integrated control curve
- Operating sequence: locked position - parallel action - turn position

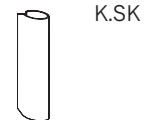
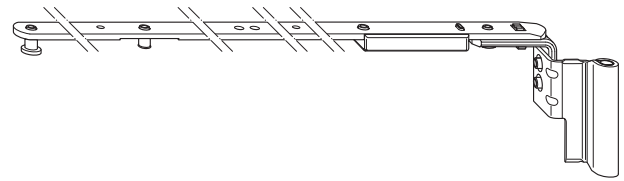

Shear hinge cap K.SK

- Can be used left and right hand

| Item designation | Item no. | Overlap | Groove centre position | VPA1 Pcs/type | VPA2 Pcs/type | VPA3 Pcs/type |
|---------------------|----------|---------|------------------------|---------------|---------------|---------------|
| SC1.PAD.20-13.LS.F9 | 5067584 | 20 | 13 | 10 BD | 60 KK | 1440 EK |
| SC1.PAD.20-13.RS.F9 | 5067583 | 20 | 13 | 10 BD | 60 KK | 1440 EK |
| SC1.PAD.20-13.LS.SL | 5067580 | 20 | 13 | 10 BD | 60 KK | 1440 EK |
| SC1.PAD.20-13.RS.SL | 5067579 | 20 | 13 | 10 BD | 60 KK | 1440 EK |
| SC1.PAD.20-13.LS.WS | 5067582 | 20 | 13 | 10 BD | 60 KK | 1440 EK |
| SC1.PAD.20-13.RS.WS | 5067581 | 20 | 13 | 10 BD | 60 KK | 1440 EK |
| SC2.PAD.20-13.LS.F9 | 5067590 | 20 | 13 | 10 BD | 80 GK | 960 EK |
| SC2.PAD.20-13.RS.F9 | 5067589 | 20 | 13 | 10 BD | 80 GK | 960 EK |
| SC2.PAD.20-13.LS.SL | 5067586 | 20 | 13 | 10 BD | 80 GK | 960 EK |
| SC2.PAD.20-13.RS.SL | 5067585 | 20 | 13 | 10 BD | 80 GK | 960 EK |
| SC2.PAD.20-13.LS.WS | 5067588 | 20 | 13 | 10 BD | 80 GK | 960 EK |
| SC2.PAD.20-13.RS.WS | 5067587 | 20 | 13 | 10 BD | 80 GK | 960 EK |

RS = right, LS = left
 WS = white, BR = brown, SL = silver, F1 = silver coloured, F3 = gold coloured, F9 = titanium coloured

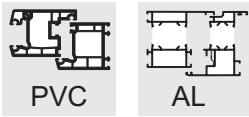

Cable transition KUE-T1

- Cable transition covered in the airgap, e. g. for motor-controlled windows
- Separable sash part and frame part which can be secured with a screw
- Serves as electric interface between the window sash and the frame
- Sash element with spring jacket and plug socket to screw into the 16 mm fitting groove
- Frame element with coupling point
- Installation drawing and laying of cables see group 15 drawing B-11-12
- Max. opening angle of the sash: 90°

Technical data

- Total length: approx. 260 mm
- Cable length of sash element: approx. 5 m
- Cable length of frame part: approx. 5 m
- Max. transmission voltage: 48 Volt DC
- Max. switching current: 2 amperes per connection cable
- Wire cross-section: 6 x 0.25 mm²
- Conductor resistance: 0.25 mm² max. 78 ohm/km
- Cable diameter: 4.9 mm
- Protection rating: IP 54 (protected against dust and splash water)
- Cable: without CFC and halogen

Included in delivery:

- Sash part
- Frame part
- 3 screws 3 x 20 mm
- 1 piece of screw 2.9 x 32 mm
- Installation Instructions

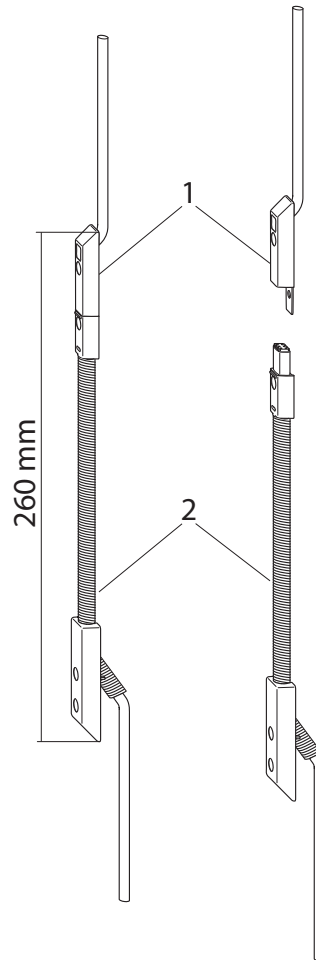

1. Frame part
2. Sash part
Wire colours: brown, white, rose, grey, green, yellow

| Item designation | Item no. | VPA1 Pcs/type | VPA2 Pcs/type | VPA3 Pcs/type |
|------------------|----------|------------------|------------------|------------------|
| KUE-T1 | 4992274 | 1 BL | 20 GK | 240 EK |

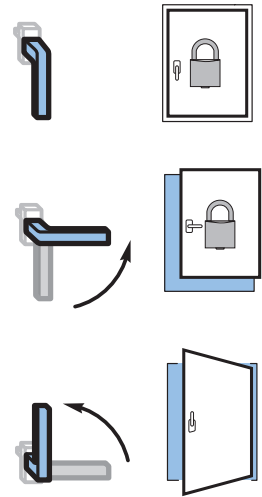
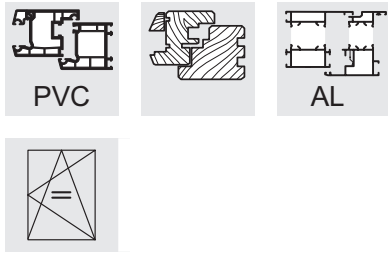

Motor drive of the fitting system HF.MD.PADM.01

- For motorised parallel action windows with a ventilation gap of approx. 6 mm.
- Provides automatic and time-controlled exchange of air
- Integrated EnOcean radio protocol
- Can be controlled via remote control, sensors via cable or radio
- Backlit touch panel
- Motor drive can be used left or right, depending on setting
- You will find further information in the original operating instructions.

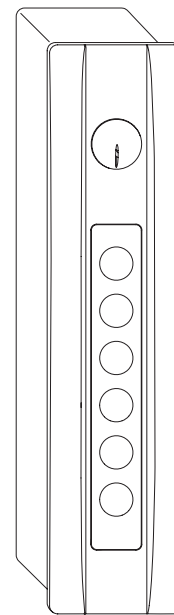

- Supply 24 VDC ± 15 %
- Residual ripple < 10 %
- Nominal current 1 A
- Standby current max. 50 mA
- Torque max. 10 Nm
- Turn angle 90° or 180°
- Running time approx. 8 sec. / 180°
- Service life > 40,000 cycles
- Duty cycle 30 % (cycle time 10 min.)

- Housing Zinc diecast, ABS, PC
- Protection type IP 40
- Temp. range -5°C ... +60°C
- Connection 6-pin screw terminal connector

| Item designation | Item no. | VPA1 Pcs/type | VPA2 Pcs/type | VPA3 Pcs/type |
|---------------------|----------|------------------|------------------|------------------|
| HF.MD.PADM.01.GR/SL | 5044072 | 1 KT | 6 K3 | 144 E1 |
| HF.MD.PADM.01.WS/SL | 5044071 | 1 KT | 6 K3 | 144 E1 |
| HF.MD.PADM.01.WS/WS | 5044068 | 1 KT | 6 K3 | 144 E1 |

GR/SL = anthracite/silver, WS/SL = white/silver, WS/WS = white/white

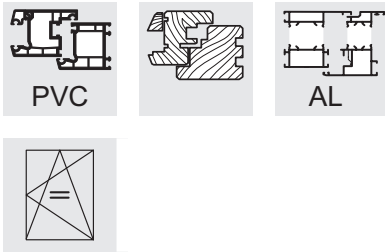

Powerpack supply HF.PS.SNT1.U.24V.1A

- To supply power for fittings motor drive HF.MD.PADM.01
- Switch box not included in delivery
- One power supply unit required per motor drive
- Only suitable for inside installation
- You will find further information in the original operating instructions.

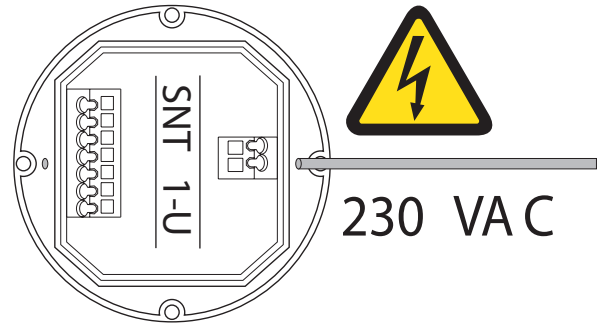

Technical data:

- Supply: 230 VAC, 50 Hz
- Nominal power: 30 VA
- Output: 24 VDC, 1 A
- Activation duration: Short-time duty 20 % ED
- Protection rating: IP 30
- Temp. range: 0 ... 50°C
- Dimensions: 50 x 47.5 x 28 mm
- Assembly: Flush-mounted switch box Ø 58 mm

| Item designation | Item no. | VPA1 Pcs/type | VPA2 Pcs/type | VPA3 Pcs/type |
|---------------------|----------|------------------|------------------|------------------|
| HF.PS.SNT1.U.24V.1A | 5044073 | 1 KT | 30 K3 | 240 E1 |

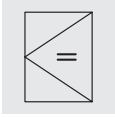
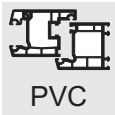

Frame parts

- Profile dependent see Group 11 (PADK), Frame Parts
- Security keep SBS.K...PAD
- Circumferential installation situation
- Available for mounting left and right hand
- Number of screws: 4
- The keep is marked "M" on the web for identification.
- Operating sequence: locked position – parallel action – turn position

Keep SBAK

- Can be used left and right hand

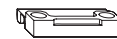
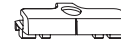
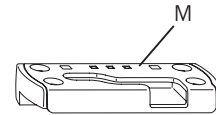

Spacer FT WSK

- Can be used left and right hand

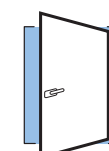
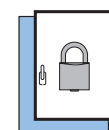
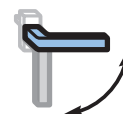

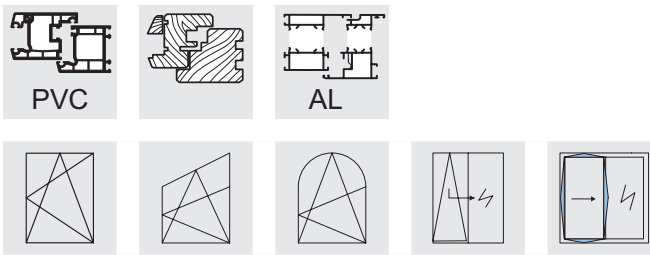

Punches for window fittings

Punch BST AP/FS

- Used to cut fitting elements
- Punch including footswitch
- Pedal operated
- Can be used together with fitting ruler
- Required operating pressure 6 bar

Ruler LIN AP/FS

- Dimensional positioning of the fitting elements to be cut
- Cutting of both central and constant parts

Fitting punch, lever AP.HH

- Used to cut fitting elements
- Manual operation
- Serves as repair punch – not suitable for permanent use

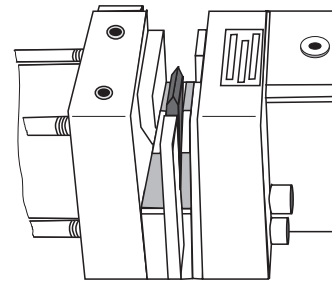

BST AP/FS

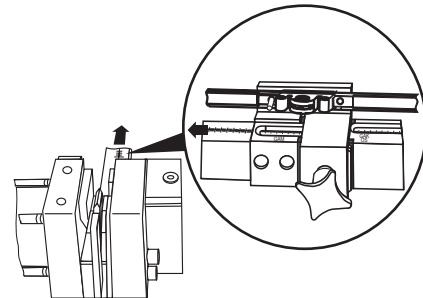

LIN AP/FS

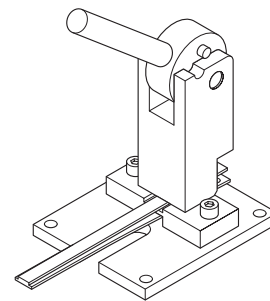

AP.HH

| Item designation | Item no. |
|------------------|----------|
| BST AP/FS LS | 1466339 |
| LIN AP/FS LS | 1466321 |
| AP.HH | 4970430 |

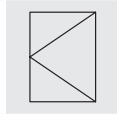
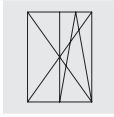
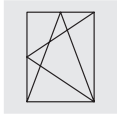
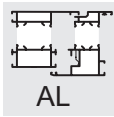
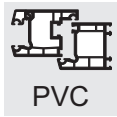

Drill jig LE.B.EL-SL.K

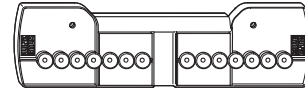

- Drilling jig to drill the pilot holes for corner and shear hinges
- Overlap dimension adjustable from 18 to 22 mm
- Preadjusted to a defined dimension
- For hinges with 6 mm pin

LE.B.EL-SL.K.3-3

- For hinges with 3 mm pin

| Item designation | Item no. | Overlap |
|----------------------|----------|---------|
| LE.B.EL-SL.K-18 | 4966329 | 18 |
| LE.B.EL-SL.K-20 | 4966340 | 20 |
| LE.B.EL-SL.K-21 | 4966341 | 21 |
| LE.B.EL-SL.K-22 | 4966342 | 22 |
| LE.B.EL.SL.K. 3-3-18 | 4966343 | 18 |
| LE.B.EL.SL.K. 3-3-20 | 4966345 | 20 |
| LE.B.EL.SL.K. 3-3-21 | 4966346 | 21 |
| LE.B.EL.SL.K. 3-3-22 | 4966347 | 22 |

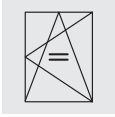
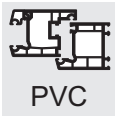

Jig PADK

- Jig for positioning security keeps SBS.K.PAB

Jig LE.N.PADK

- Used for positioning SBS.K.PAB keeps in the frame rebate of the corner area
- Can be used left and right hand

Jig LE.N.SBS.K

- Used for positioning SBS.K.PAB keeps in the frame rebate (except the corner areas)
- Can be used left and right hand

LE.N.PADK

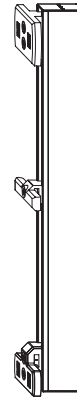

LE.N.K.SBS.K



| Item designation | Item no. | VPA1 Pcs/type | VPA2 Pcs/type |
|-------------------------------|----------|------------------|------------------|
| LE.N.PADK | 4969653 | 25 KK | 200 EK |
| LE.N.K.SBS.K.PAD.RC2.BD | 5004340 | 25 EA | |
| LE.N.K.SBS.K.PAD.RC2.OB.UN | 5004341 | 25 EA | |
| LE.N.K.SBS.K.PAD.RC2.UN | 5004342 | 25 EA | |
| LE.N.K.SBS.K.PAD.RC2.GTR.BD.1 | 5004343 | 25 EA | |
| LE.N.K.SBS.K.PAD.RC2.GTR.BD.2 | 5004344 | 25 EA | |
| LE.N.K.SBS.K.PAD.RC2.GTR.BD.3 | 5004345 | 25 EA | |
| LE.N.K.SBS.K.PAD.RC2.GTR.BD.4 | 5004346 | 25 L1 | |
| LE.N.K.SBS.K.PAD.RC2.GTR.BD.5 | 5004347 | 25 L1 | |
| LE.N.K.SBS.K.PAD.RC2.GTR.BD.6 | 5004348 | 25 L2 | |

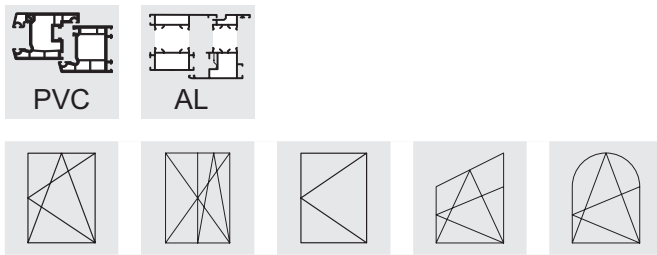

Jigs

- Used to position keeps in frame rebate
- Can be used left and right hand
- How to use please see mounting instructions

Different models:

- LE.N.K jig, constant handle position
- LE.N.T jig, central handle position (telescopic jig), locking drive GAM
- LE.N.T.ST jig, central handle position (telescopic jig), double-sash windows
- LE.N.T.GAVM jig, central handle position (telescopic jig) locking drive GAVM

Positioning aid LE.SB.N

- Serves the purpose of positioning the locking keeps within the frame rebate
- Can be used left and right hand
- Especially used for special window shapes (round or sloping head windows)
- How to use please see mounting instructions

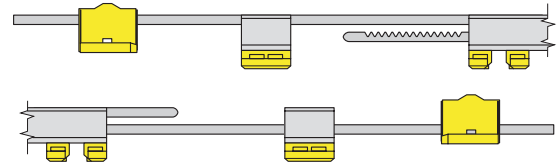

| Item designation | Item no. |
|---------------------|----------|
| LE.N.T.GAVM 300 | 4936773 |
| LE.N.T.GAVM 420 | 4937047 |
| LE.N.T.GAVM 620 | 4937061 |
| LE.N.T.GAVM 920 | 4937063 |
| LE.N.T.GAVM 1320 | 4937064 |
| LE.N.T.GAVM 1850 | 4937065 |
| LE.N.T.ST.0550-1200 | 4926548 |
| LE.N.T.ST.1201-2170 | 4926549 |
| LE.N.K.0290-0709 | 4926540 |
| LE.N.K.0710-1100 | 4926541 |
| LE.N.K.1101-1550 | 4926542 |
| LE.N.K.1551-2225 | 4926543 |
| LE.N.K.2225-4 | 4941065 |
| LE.N.T.0710-1050 | 4926545 |
| LE.N.T.1051-1800 | 4926546 |
| LE.N.T.1801-2300 | 4926547 |
| LE.SB.N | 5039041 |

13 Installation Instructions

155 - 182

13

13.1 Notes on these assembly instructions

13.1

13.2 Shortening the fittings

13.2

13.3 Assembly of the turn fitting system

13.3

13.6 Function test / Operation

13.6

Notes on these assembly instructions

Prerequisites:

The mounting instructions are designed for mounting Winkhaus activPilot fittings for windows and glazed doors only. Fittings are designed for the following sash rebate sizes and sash weights:

- Min. sash rebate width 460 mm
- Max. sash rebate width 1475 mm
- Max. sash rebate height 2300 mm
- Max. sash size 2.5 m²
- Min. sash rebate height 695 mm (surface-mounted cable transition)
- Min. sash rebate height 820 mm (concealed cable transition)
- Max. sash weight 100 kg
- (1 mm glass thickness = 2.5 kg / m²)
- Ratio between sash rebate width: Sash rebate height ≤ 1.5
- Airgap 12 mm
- Overlap 20 mm
- Groove centre position 13 mm
- Frame rebate depth min. 29 mm
- Approved for centre gasket systems and rebate sealing systems with rain guard.



Note: In order to ascertain the permissible sash sizes and sash weights, please refer to the diagrams in the chapter "General Product Information".

13.1

Persons involved in mounting fittings must have read and understood this fitting guide. Observe production liability information for all work with fittings. Manufacturer will accept no liability in cases of failure to comply with this guide, deployment of insufficiently qualified staff and unauthorised alterations.

The respective overall fitting must be selected from the original fitting components range. Winkhaus accepts no liability if non-original or unauthorised system accessory parts are used.



Please note! Winkhaus does not provide fastening screws for fitting. Always use fastening screws suitable for the window type and window dimensions.



Note: activPilot Comfort fittings are not suitable for use in panic doors!

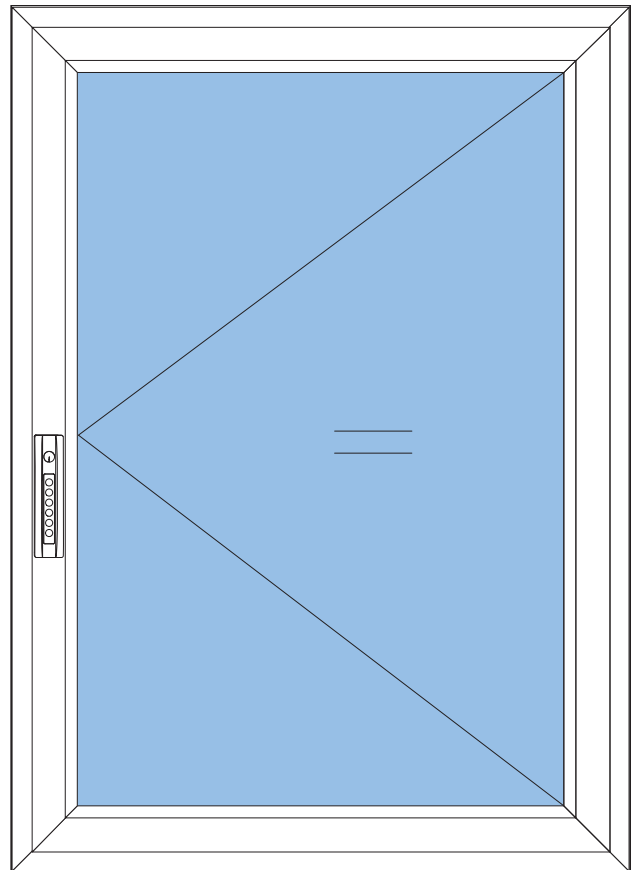

Standard profile dimensions

See figure: Profile cross-section

The fitting can be used on PVC-U windows with a standard eurogroove.



activPilot Comfort fittings are suitable for centre gasket systems or rebate sealing systems in combination with rain guards.

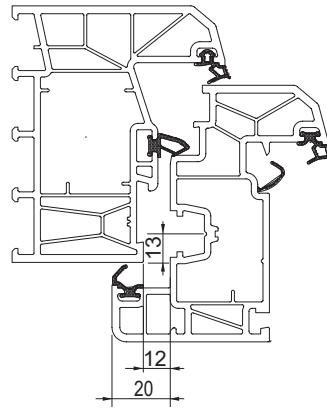

Profile cross-section

Shortening the fittings

A detailed description on shortening of fittings is available here. This description will be referred to in these assembly instructions.

See figure: Fittings prior to punching

- Always insert the face plate (1) and drive rod (2) perpendicularly from the top with the face plate (1) pointing to the pressure cylinder.

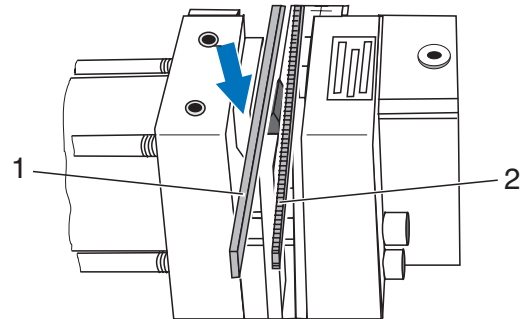

Fittings prior to punching

See figure: Fittings after punching

- After punching, always remove the face plate (1) and drive rod (2) perpendicularly in an upwards direction.

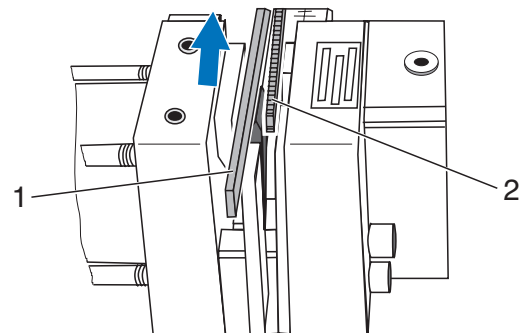

Fittings after punching

See figure: Cleaning the supporting surfaces

- Keep the supporting surfaces (3 and 4) clean.

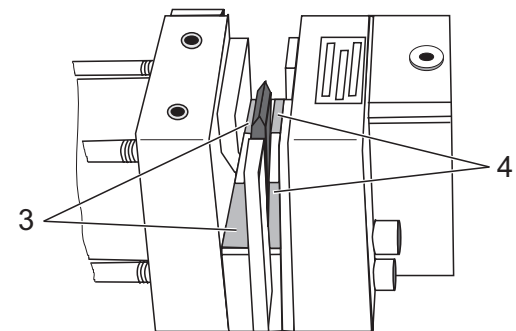

Cleaning the supporting surfaces

Shorten the drive rod GAM (central handle position)

See figure: Marking GAM

- Set measuring value FFH on the measuring device to the GAM mark.



Please note! If the GAM scale is displaced by one submarking, this corresponds to a longitudinal shift of 2 mm.

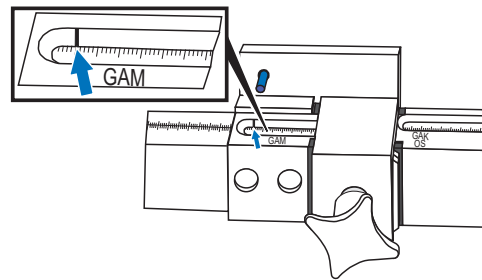

Marking GAM

See figure: Position for shortening drive rod

- Position the GAM drive rod at the scale; slot drill hole (2) onto bolt (1).
- Turn the GAM drive rod around, and slot the drill hole (3) onto the bolt (1), then trim the other side.
- Shorten the drive rod using the fitting punch.

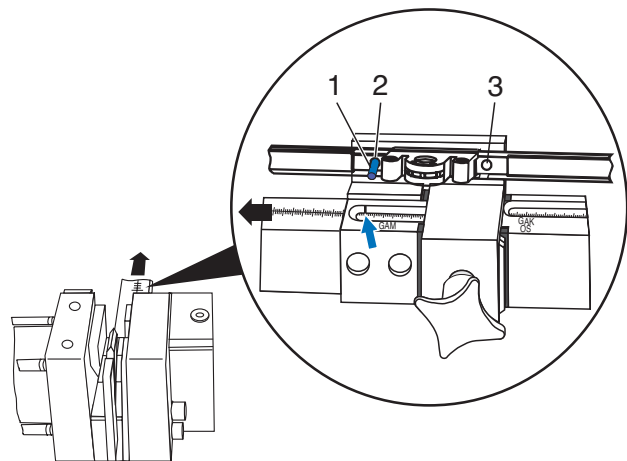

Position for shortening drive rod

Shorten the GAK / GASK drive rod (constant handle position) and top rod OS



Note: The double-sash drive rod must be trimmed before delivery.

See figure: Markings GAK and OS

- Set the measuring value FFH (GAK/GASK) or FFB (OS) on the measuring device to the GAK/OS mark.



Markings GAK and OS

See figure: Position for shortening drive rod and/or top rod

- Cutting the top rod OS...
 - Position the drive rod GAK/GASK (fixed handle position) (1) or the top rod OS (1) at the bolt (2).
 - Shorten the drive rod (1) or the top rod (1).

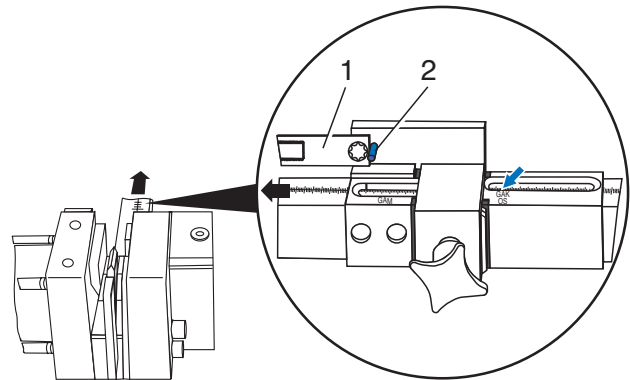

Position for shortening drive rod and/or top rod

Only applies to top rod OS1.600 (OS1.PA.600/OS.XL):

See figure: Position for shortening top rod

- Position the top rod (1) with square holes at bolt (2). At the same time press the offset (see arrow) against the bolt (2).
- Shorten the top rod (1).

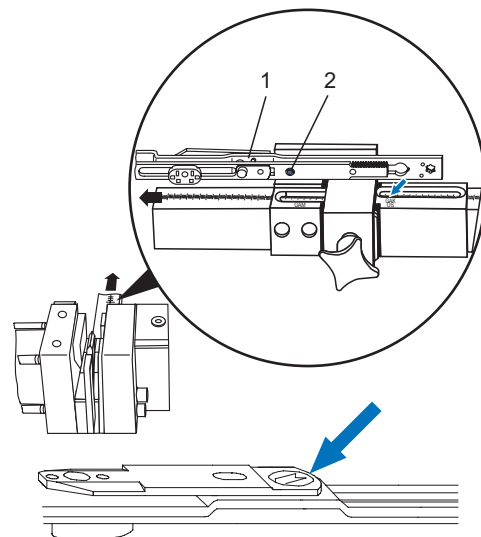

Position for shortening top rod

Mounting of fittings on sash

Rectangular turn window

Prepare the window for fitting. Then proceed as follows:

i Note: The following figures refer to a window for right hand use. When fitting a window for left-hand use, the figures will be mirror-inverted.

The following also applies:

- When viewing the window from the inside, the symbol is depicted as a full line.
- When viewing the window from the outside, the symbol is depicted as a dotted line.

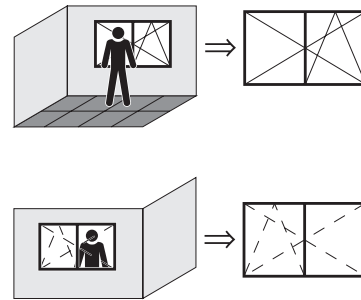

Determine the handle height:

Handle height for drive rod GAM

See figure: Sash rebate height FFH with central handle height GM

If you use a GAM drive rod ... (central handle position), the dimension GM is half the sash rebate height FFH.

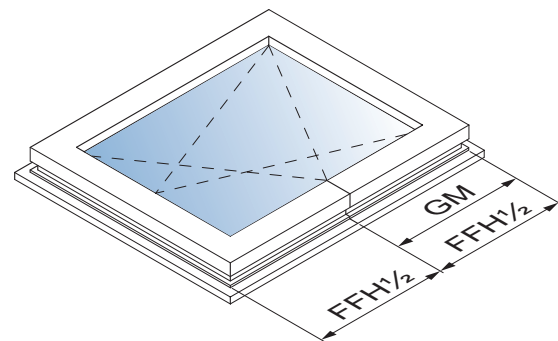

Sash rebate height FFH with central handle height GM

Handle height for drive rod GAK

See figure: Sash rebate height FFH with constant handle position GK

If you use a GAK drive rod ... (constant handle position), dimension GK changes to reflect the sash rebate height FFH. The exact dimensions are specified in the following table.

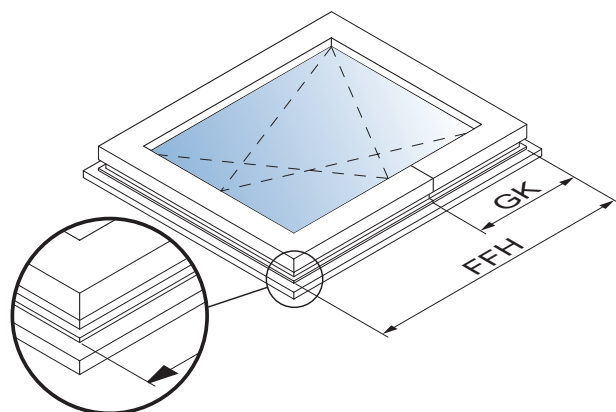

Sash rebate height FFH with constant handle position GK

See figure: Synoptical table: sash rebate height (FFH) / handle position (GK)

The table on the right gives a survey on the handle height (GK) of GAK with regard to the sash rebate height (FFH).

| FFH | GK |
|-------------|------------|
| 230 – 324 | GK = 114 * |
| 325 – 420 | GK = 114 * |
| 421 – 460 | GK = 210 |
| 461 – 700 | GK = 210 |
| 701 – 850 | GK = 260 |
| 851 – 1100 | GK = 375 |
| 1101 – 1325 | GK = 550 |
| 1326 – 1525 | GK = 550 |
| 1526 – 1775 | GK = 550 |
| 1776 – 2000 | GK = 1050 |
| 2001 – 2225 | GK = 1050 |

Synoptical table: sash rebate height (FFH) / handle position (GK)
 * Requires the use of E3 corner drive

See figure: Scale drawing "Gear lock"

- Drill holes for gear case (ø 12 mm) as per scale drawing.

Mill the gear housing from the rebate side.

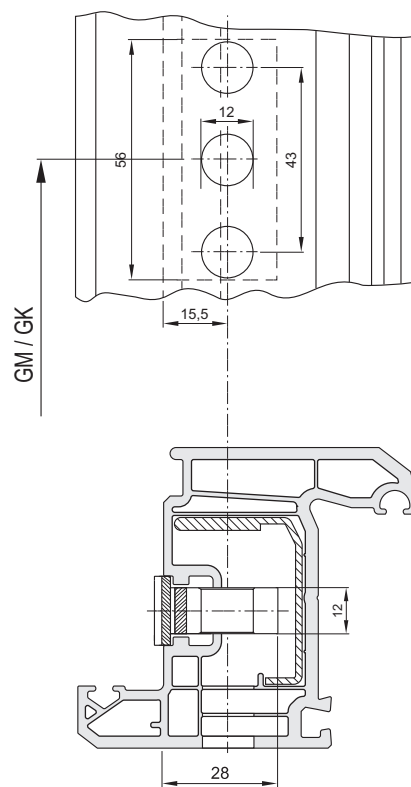

Scale drawing "Gear lock"

See figure: Corner drive E1

- Fit the corner drive (2) into the fitting groove at the top of the sash so that the octagonal bolt is on the top side.
- Fit the corner drive E1 (1) into the fitting groove at the bottom of the sash so that the octagonal bolt is on the drive side.
- Fix both corner drives (1, 2) on the drive side with a single screw each.
- Measure the sash rebate height (FFH).

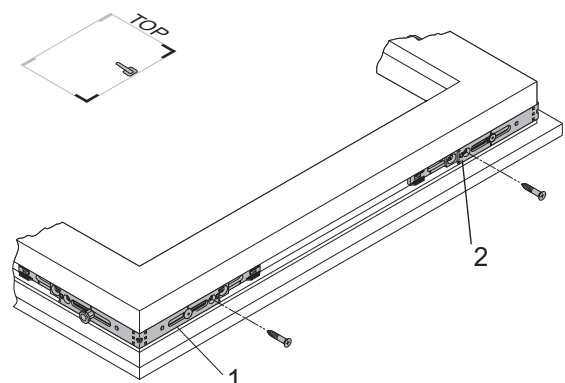

Corner drive E1

See figure: Drive rod GAM/GAK

- Cut the drive rod according to the instructions.
- Mount the drive rod:
 - Abut the drive rod (2) flush against the corner drive (3).
 - Allow the teeth on the drive rod to click into position on the gear rack on the corner drive.
 - Clip the drive rod into the corner drive (1) in the same way.
 - Press the drive rod into the eurogroove.
 - Screw the drive rod from the bottom up.

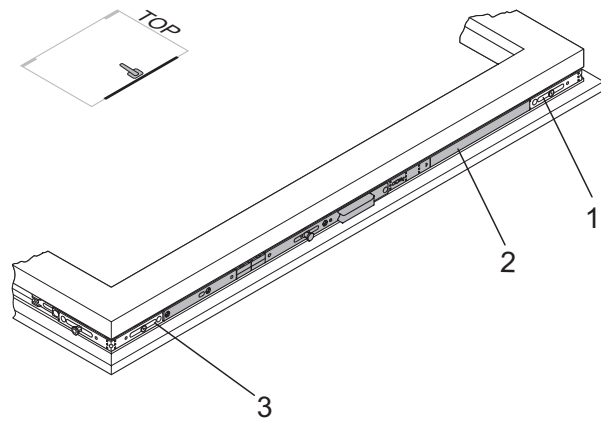

Drive rod GAM/GAK

See figure: Corner drive E2

- Fit the corner drive (1) into the fitting groove at the top of the sash so that the octagonal bolt is on the hinge side.
- Fasten the corner drive on the sash using a screw (2).
- Measure the sash rebate width (FFB).



Note: If you use a OS1.600 top rod, replace top corner drive E2 with top corner drive E3.

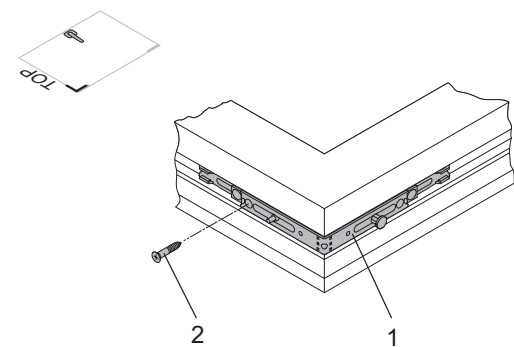

Corner drive E2

See figure: Top rod OS

- Cut the top rod (see chapter 'Shortening the fittings').
- Insert the top rod and screw into position.
 - Fit the top rod flush against the corner drive (1).
 - Allow the gear teeth to click into place on the rack in the corner drive.
 - Clip the top rod into the corner drive (3) in the same way.
 - Press the top rod into the fitting groove.
 - Screw the top rod from the hinge side to the drive side.

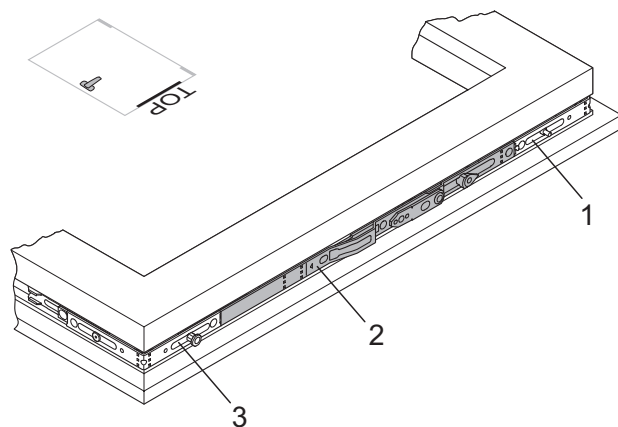

Top rod OS

See figure: Shears

- Mounting the shear:
 - Swivel out the hold-up shore (2) (see arrow).
 - Clip shear into the top rod (3) using mushroom bolt (4).
 - Press the shear bolt (5) into the spring on the hold-up shore.
 - Swivel the hold-up shore and shear to home position.
 - Press the shear onto the bolt (1).

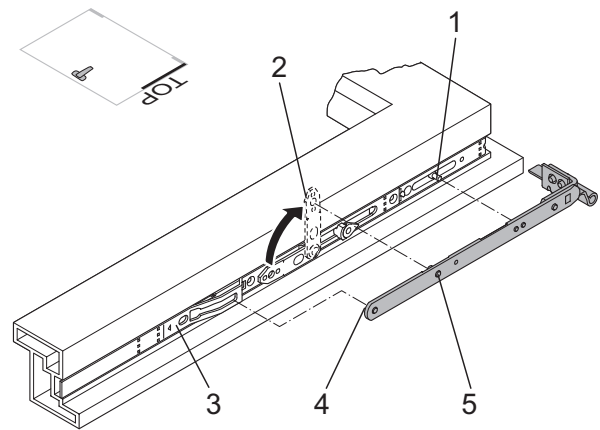

Shears



The sash can fall out and cause injuries if the shear and top rod are not securely fastened.

See figure: Interlocking rod MK.PA

- Install Interlocking Rod on the hinge side.
 - Fit the interlocking rod (1) flush against the corner drive (2).
 - Click the interlocking rod gears into the teeth of the corner drive.
 - Press the interlocking rod into the fitting groove.
 - Screw the interlocking rod from the top down.
 - Tighten the screw (3) fully to release the central fastening.
 - If necessary, use further interlocking rods / extension rods.

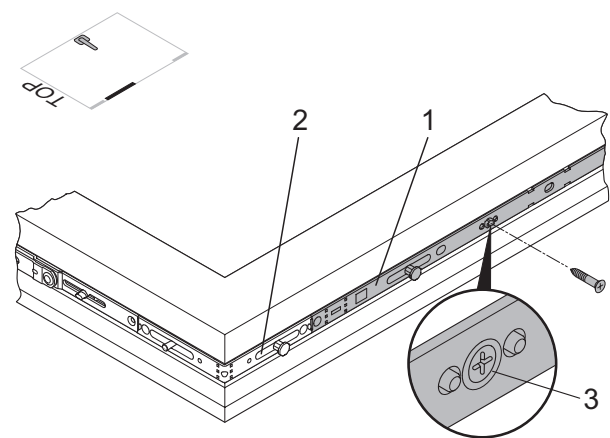

Interlocking rod MK.PA



Please note! Damage to fittings. If the central fastening is not released, the locking device cannot be actuated. Use of force will lead to torsion of the fittings. Always insert the screw fully up to the stop.

See figure: Corner drive E1

- Corner drive E1
 - Fix the screws necessary for the corner drive (1).

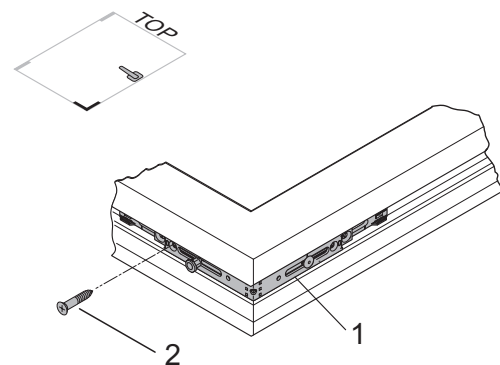

Corner drive E1

See figure: Sash hinges

- Fitting the sash hinge:
 - Fit the sash hinge into the eurogroove at the bottom of the sash so that the octagonal bolt is on the underside.
 - Fix the sash hinge on the hinge side with 2 screws and on the underside using 1 screw.
 - Measure the sash rebate width (FFB).

i Note: Fit the sash hinge in place with \varnothing 3.9 to 4.2 mm screws. Min. screw length 25 mm. Make sure that the sash hinge is entirely flush within the eurogroove.

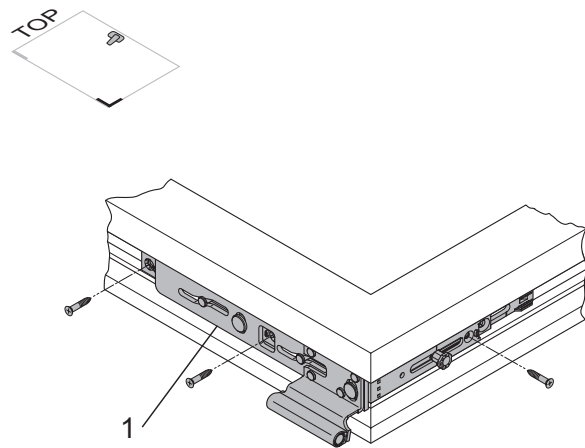

Sash hinges

! Important to observe for Trocal 88+ profile system! For Trocal 88+ please remove the centre bar at the frame (bottom hinge side, at level of sash hinge). From frame rebate edge approx. 70 mm to the top!

See figure: Support plate AL.M.F12

- Mount the coupling element, the interlocking rod and the support plate on the underside:
 - Fix the interlocking rod to the corner drive, depending on the sash rebate width.
 - Cut the coupling element to the required dimension.
 - Abut the coupling element against the sash hinge with the side to be cut pointing towards the drive side.
 - Click the coupling element gears into the teeth of the sash hinge.
 - Tighten the screw (3) fully to release the central fastening.
 - Fix the support plate on the coupling element with a screw.

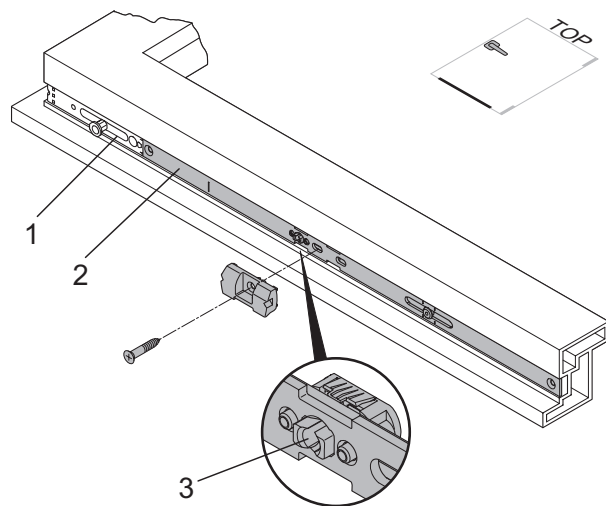

Support plate AL.M.F12

See figure: Fail safe device FSF

- Mount the fail safe device:
 - Insert the fail safe device on the hole pattern of the drive rod and fix with a screw.
 - If required, turn the head by 90° (depends on profile).
 - Mounting a frame part is not necessary.

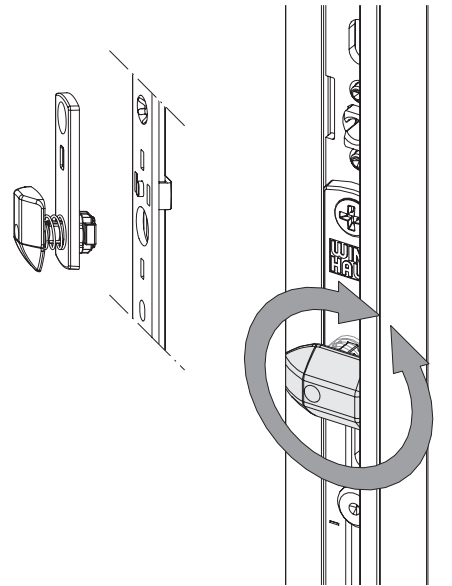

Fail safe device FSF

Important to know:

- The component's delivery state is neutral with regard to the DIN direction!
- After installation the tip of the pressure piece must be directed towards the frame!
- For airgaps smaller or larger than 12 mm an adjustment is possible by turning the plastic part to the left or to the right!



Please note! Check if all screws are fixed into place on the fitting parts.



Note: For a sash rebate height (FFH) and/or sash rebate width (FFB) of approx 800 mm (depending on the profile) an interlocking rod should also be fitted hinge-side and/or horizontally at the bottom / top. Observe the profile system supplier's processing guidelines in this respect.

Installation of cable transition

See figure: Installation drawing cable transition

- Installation of the frame part with coupling point on the hinge side (frame)
- Provide for a $\varnothing 8$ mm passage hole for the cable to go through the frame at a height of RFK 480 mm (frame rebate edge). The cable should be led out laterally in order to avoid that it is damaged when the window is opened.
- Run the cable through the frame. Provide cable loop in the frame.
- Use a screw $\varnothing 3 \times 20$ mm to fix the frame part (included in the scope of delivery).
- Attach the cable reserve to the frame from the outside (transport securing device).

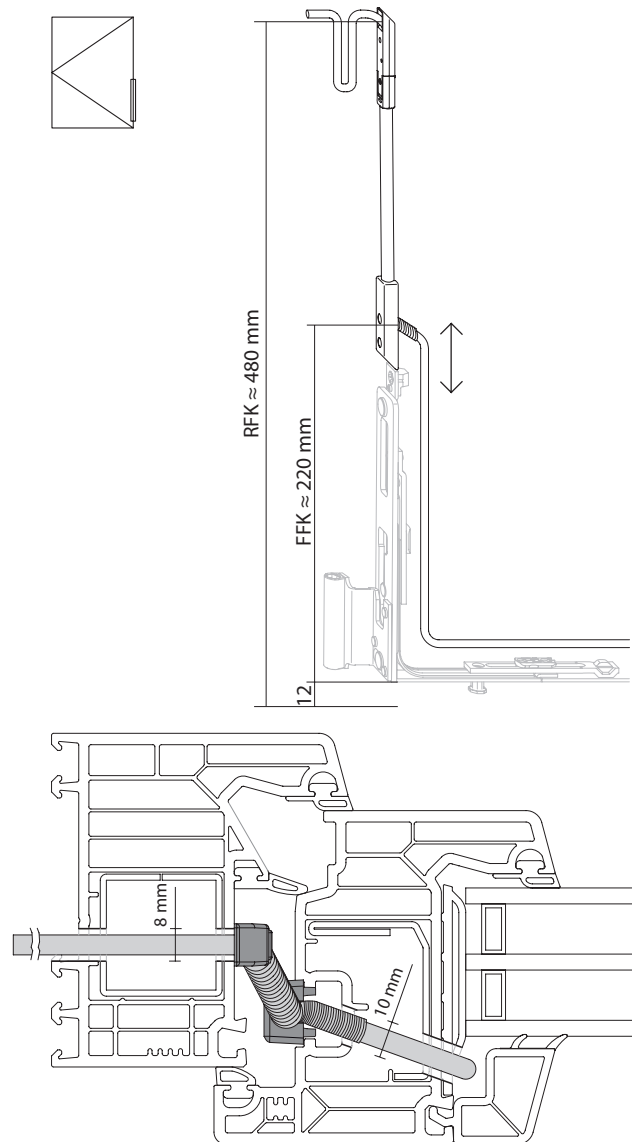

Installation drawing cable transition
 FFK = sash rebate edge
 RFK = frame rebate edge

See figure: Installation drawing cable transition

- Installation of the sash element with spring jacket and plug socket (sash/fitting groove)
- Provide for a $\varnothing 10$ mm passage hole for the cable at a height of FFK 240 mm (sash rebate edge). The hole must be drilled from the fitting groove to the glass area.
- The drill hole must be burr-free. The spring must be slightly preloaded (10 mm), even if the window is closed.



Note: Run the cable only after inserting the window pane and observe the installation position.

See figure: Cable duct of the motor

- Drilling the cable outlet hole for the fitting drive (sash/ drive side)
- Prepare a $\varnothing 12$ mm passage hole approx. 130 mm below the drive hole (see picture) to be drilled into the first chamber of the sash (e.g. the glass rebate). In addition, provide for another $\varnothing 12$ mm hole from the glass area into the first chamber.



Note: The drill hole must be burr-free.

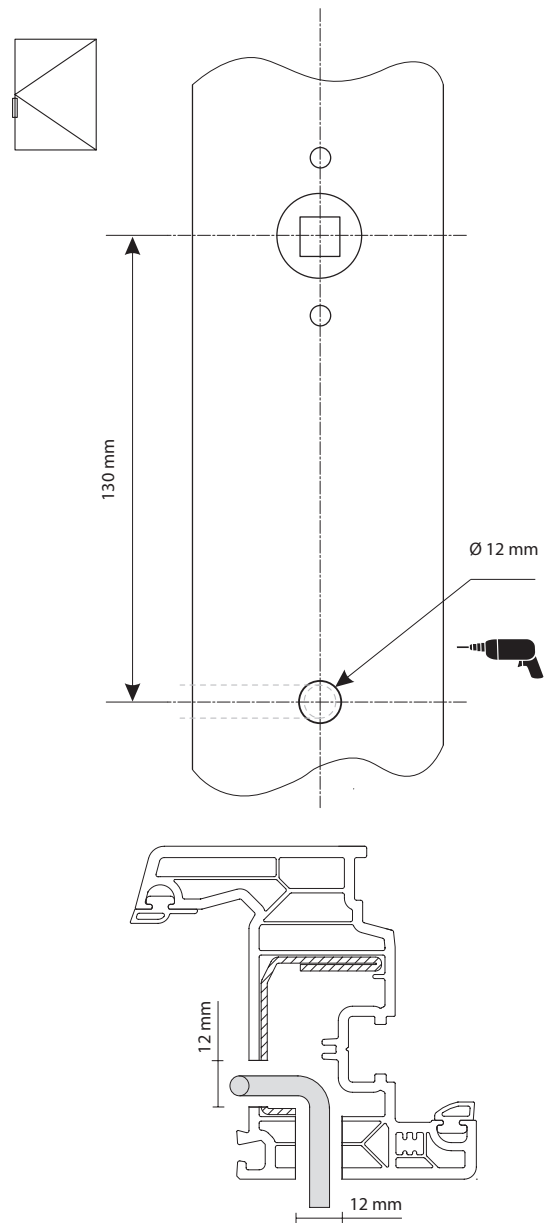

Cable duct of the motor

See figure: Cable installation on the sash

- Cable installation on the sash
 - Insert the pane first.
 - Lay the cable of the sash element for the motor through the window sash (e. g. glass rebate).
 - On the drive side the cable must be fed out of the hole (approx. 10 cm). Provide an additional cable loop in the profile.
 - Fix the sash part of the cable transition in the fitting groove at the hinge side using a screw $\varnothing 2.9 \times 32$ mm (included in the scope of delivery).
 - In case the cable was laid within the glazing bead, insert the glazing beads.

 Note: Please provide for a 3 - 5 cm cable reserve for the spring extension behind the sash component (hinge side)!

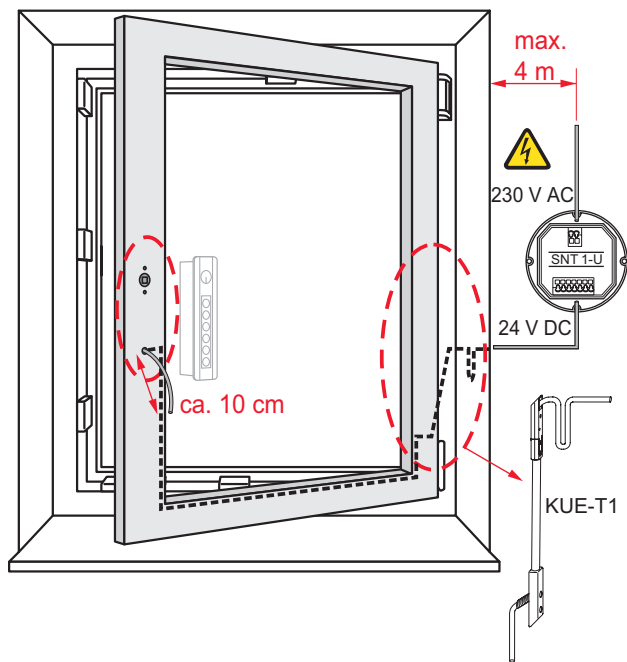
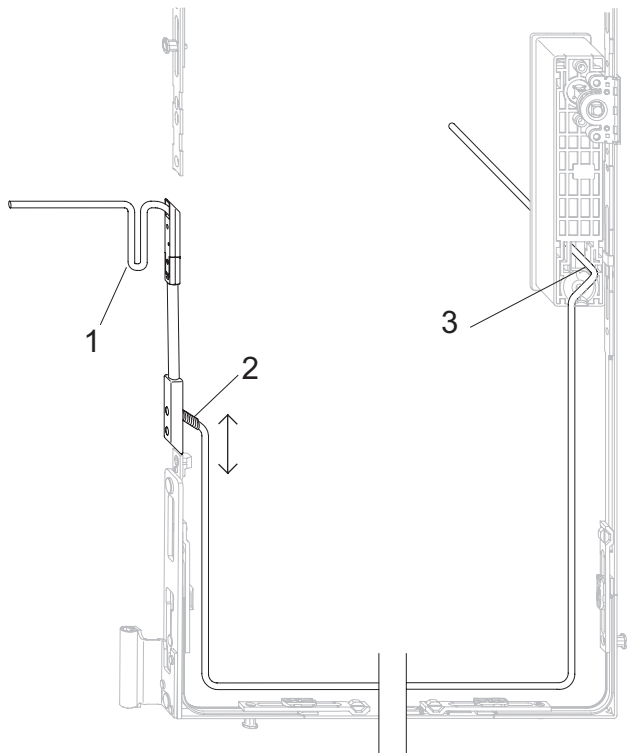

13.3

Cable installation on the sash

See figure: Connect cable transition

- Connecting the frame and sash parts
 - Establish the plug-in connection after mounting the sash.
 - Fasten the female connector to the frame part with screws $\varnothing 3 \times 20$ mm (included in the scope of delivery).

 Important: When removing the sash (e. g. when the frame is installed into the wall reveal) please completely remove the screw used to secure the socket. Insulate open wires of the cable!

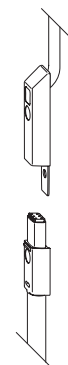

Connect cable transition
 (top: frame part; bottom: socket of the sash part)

Mounting of fittings on the window frame

For parallel action rectangular turn window

i Note: Do not fit the shear and corner hinges until after fitting the keeps.

See figure: Holes for corner and shear hinges

- Drill \varnothing 2.5 to 3 mm pilot holes for shear and corner hinges and drill \varnothing 6 mm pilot holes for spindle plug positions.
- Use the template (1) to drill holes for corner hinge (3) and shear hinge (2). Distance between drill holes for shear and corner hinges is the same.

i Note: Do not fit the shear and corner hinges until after fitting the keeps.

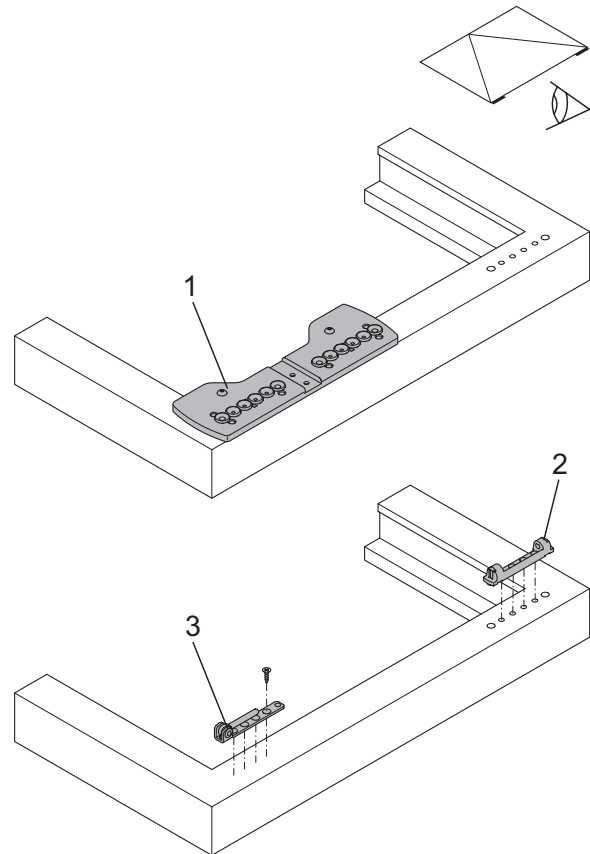

Holes for corner and shear hinges

Positions of keeps (basic equipment)

For parallel action rectangular turn window

The following figures show the keep position options. The number of keeps depends on the size of the window.



Note: The dimensions shown in the figures refer to the frame rebate edge to keep profile edge or frame centre to the keep!

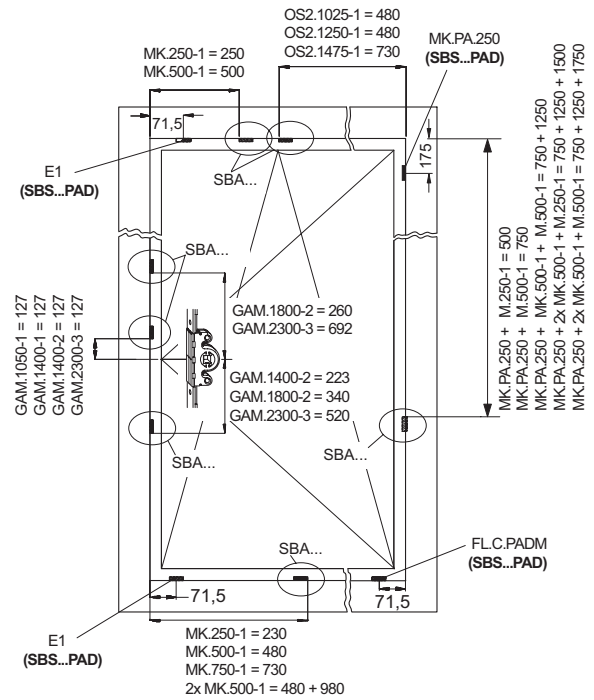

Keep positions DK "central handle position"

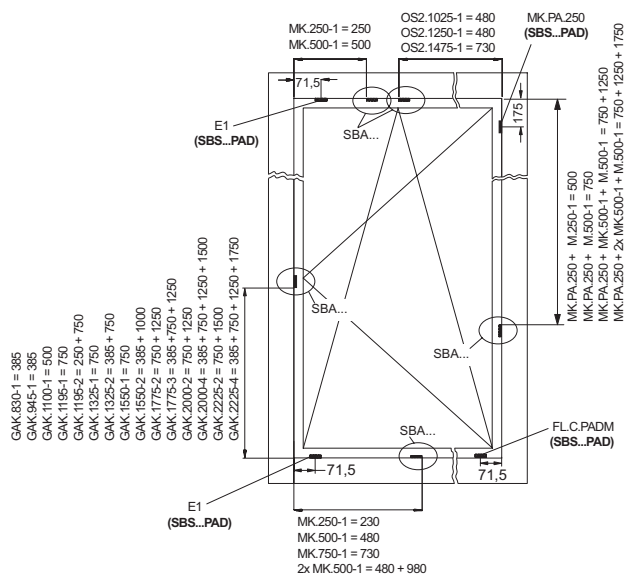

Keep positions DK "constant handle position"

Positions of keeps (RC2)

The following figures show the keep position options. The number of keeps depends on the size of the window.



Note: The keeps are security keeps SBS...PAD. The measurements refer to the "centre" of the keep.

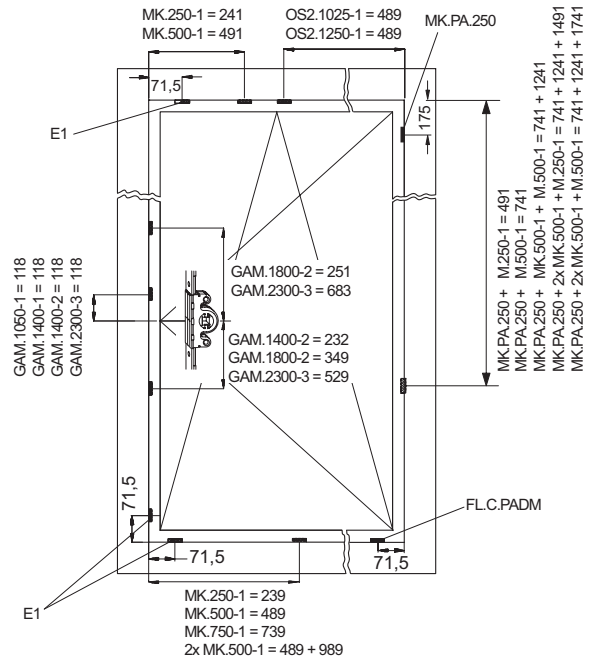

Keep positions DK "central handle position"

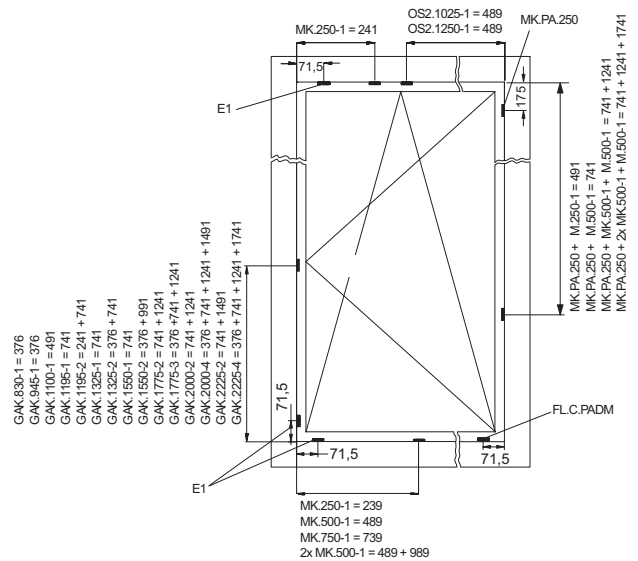

Keep positions DK "constant handle position"

Fitting the keeps

Handling of mounting jigs is explained by reference to the L.E.N.K. 710-1100 mounting jig in the following. Other mounting jigs are used in the same way. To position keeps, place the mounting jig on the frame rebate edge.

Labelling of mounting jigs



Horizontal attachment = red element (for top rod and interlocking rod)



Vertical attachment = yellow element (for drive rods and interlocking rods)

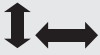

Vertical / horizontal attachment = blue element (for corner drives)



= Keep run-in

Keep SBS...PAD drive side, top corner drive for E1

See figure: SBS...PAD

- Use a PADK jig for the keeps needed for the parallel position activPilot Comfort.
- Align the mounting jig with the red element in the corner.
- Position the SBS... keep on the red element marked E1.PA, FL...PA, E1.

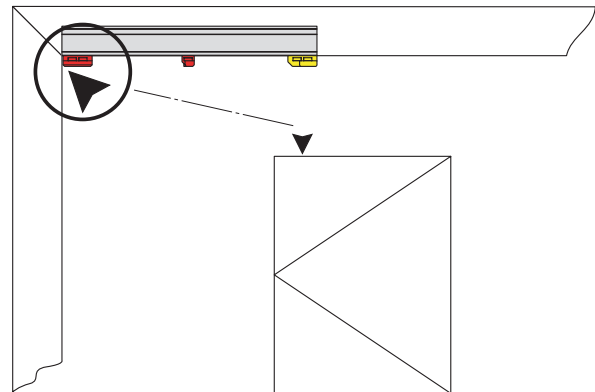

SBS...PAD

Keep SBS...PAD drive side bottom corner drive for E1

See figure: SBS...PAD bottom

- Use a PADK jig for the keeps needed for the parallel position activPilot Comfort.
- Align the mounting jig with the red element in the corner.
- Position the SBS... keep on the red element marked E1.PA, FL...PA, E1.

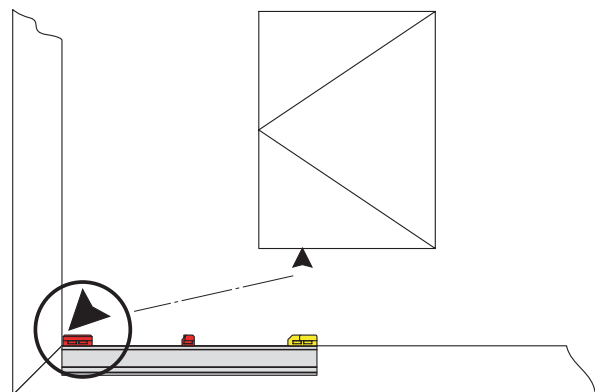

SBS...PAD bottom

Keep SBS...PAD top hinge side for MK.PA.250

See figure: SBS...PAD

- Use a PADK jig for the keeps needed for the parallel position activPilot Comfort.
- Position the mounting jig with the yellow element in the upper corner.
- Position the keep SBS...PA.. on the red element marked MK.PA.250.

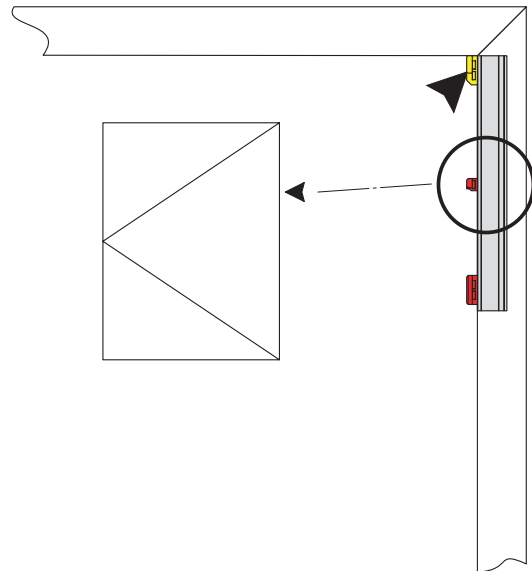

SBS...PAD

Keep SBS...PAD for sash hinge at bottom hinge side

See figure: SBS...PAD

- Use a PADK jig for the keeps needed for the parallel position activPilot Comfort.
- Position the mounting jig with the red element in the corner.
- Position the SBS...PAD keep on the red element marked E1.PA, FL...PA, E1.

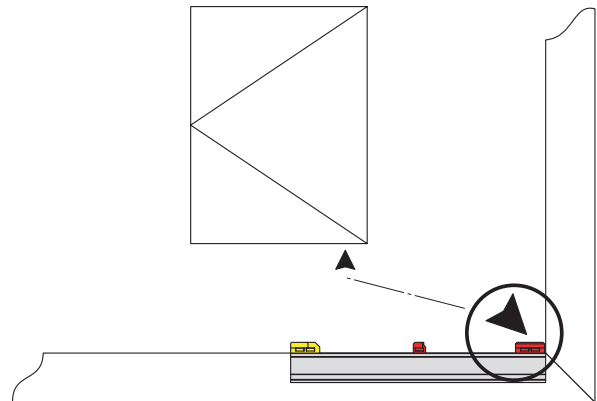

SBS...PAD

See figure: Keeps hinge side

- Keeps for interlocking rods, hinge side
- Align the mounting jig with the yellow element in the top corner.
- Position the keep for interlocking rod on the yellow element.



Note: The labelling on the interlocking rod must match the labelling on the yellow templates. The interlocking rod MK is labelled e.g. "MK.750-1".

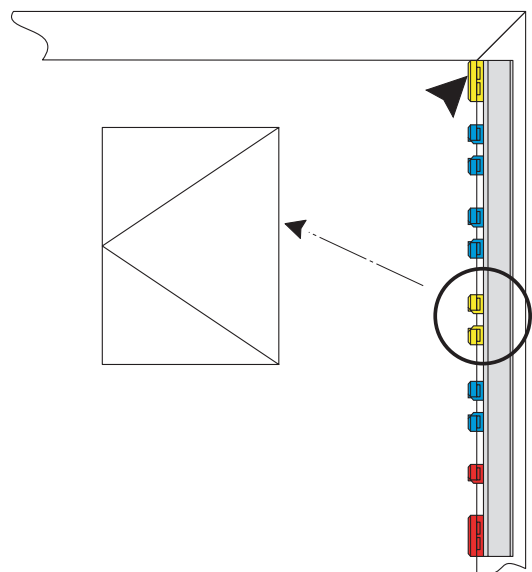

Keeps hinge side

Interlocking Rod M..., bottom, horizontal

See figure: M bottom horizontal

- Align the mounting jig with the red element in the lower corner.
- Position the keep on the blue element marked "M" or "MK".

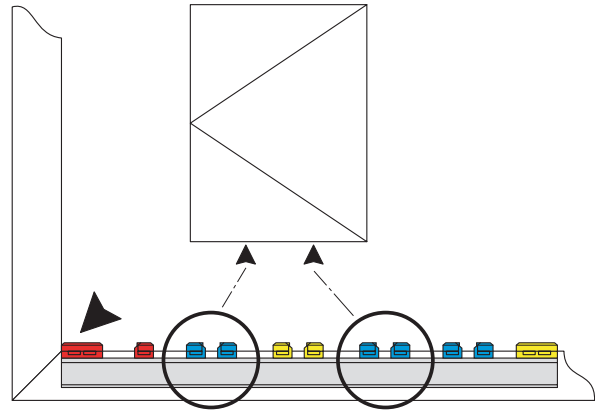

M bottom horizontal

Keep for top rod OS...

See figure: Keep for top rod OS...

- Align the mounting jig with the red element in the top corner.
- Place the keep SBA on the blue element labelled "OS. ...".

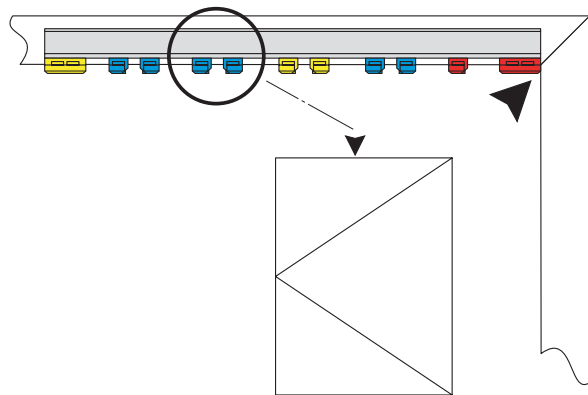

Keep for top rod OS...

Keeps for vertical GAK drive rod

See figure: SBA... for vertical GAK

- Align the mounting jig with the yellow element in the bottom corner.
- Place the SBA. ... keeps on the yellow and blue elements marked "GAK. ...".

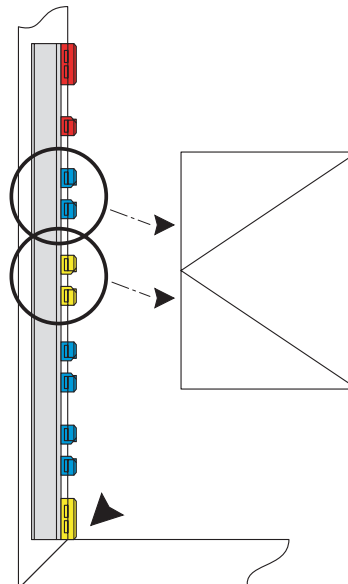

SBA... for vertical GAK

Keeps for GAM

See figure: Keeps for GAM

- Attach the corresponding mounting jig labelled “top” or “bottom”.
- Fit keeps in line with the labelling on the mounting template.

There are three telescopic jigs depending on the window height:

- LE.N.T. 0710-1050 for drive rod GAM 1050-1
- LE.N.T. 1051-1800 for drive rod GAM 1400-1/2 / 1800-2
- LE.N.T. 1801-2300 for drive rod GAM 2300-3



Note: The labelling on the drive rod must match the labelling on the yellow templates.

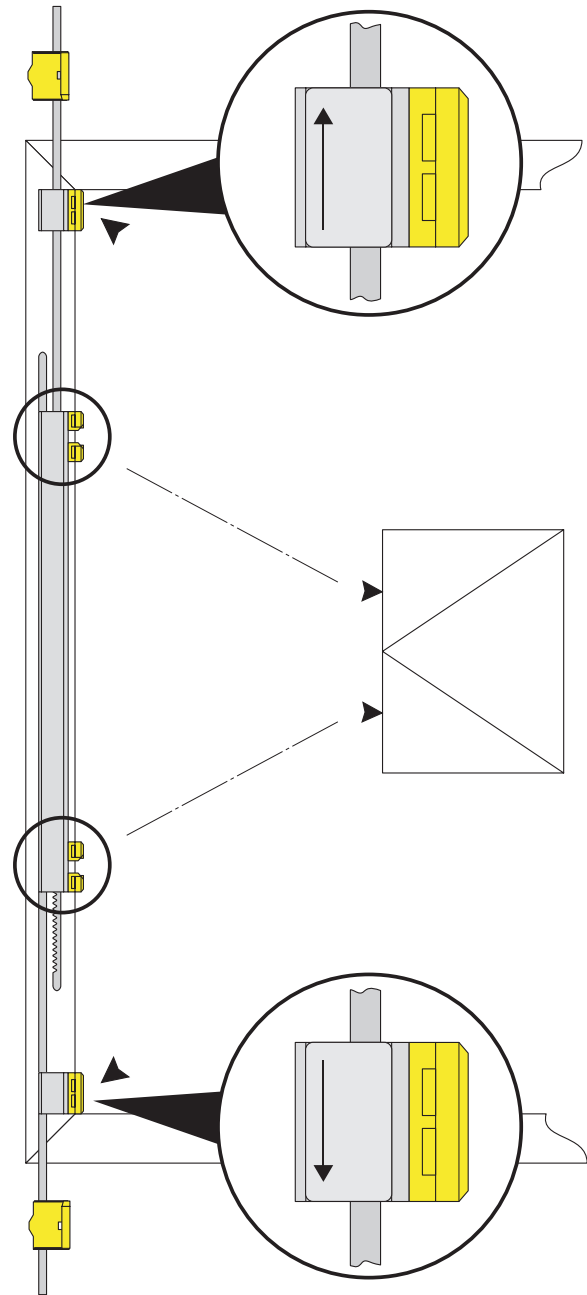

Keeps for GAM

Mounting shear and corner hinges

See figure: Shear and corner hinges

- Fix the shear hinge (2) and corner hinge (1) with screws.



Note: Window builders must ensure that hinges and their anchorings are designed to support the expected loads and professionally mounted.

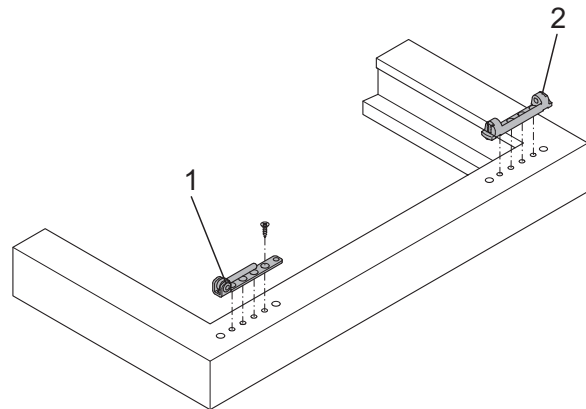

Shear and corner hinges



Important: The screw connections of the load-bearing fitting components, such as corner, shear and sash hinges must be performed according to the TBDK guidelines. Adapt the drilling diameter for the fixing screws, the screw diameter and the screw length to the load situation.

Sash installation and removal

Surface-mounted hinge parts

Fitting the sash

- Mount the sash, adjust for a good seal and fit the pin to secure against the shear hinge.
- Push all end caps and sealing caps onto the shear and corner hinges.



Note: Insert the pin from the underside (see arrow).

- Connect the sash and frame part at the cable transition.
- Screw in the safety screw at the cable transition.

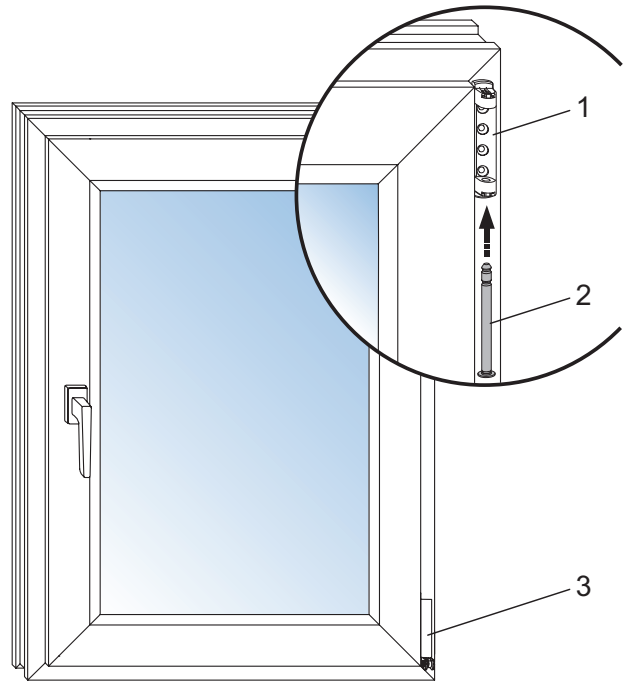

Shear and corner hinge

Removal of the sash

- Open the sash 90°.
- Fully unscrew the safety screw of the cable transition.
- Separate the frame and sash part of the cable transition.
- Close the sash.
- Release the pin from the shear hinge.
- Remove the sash.

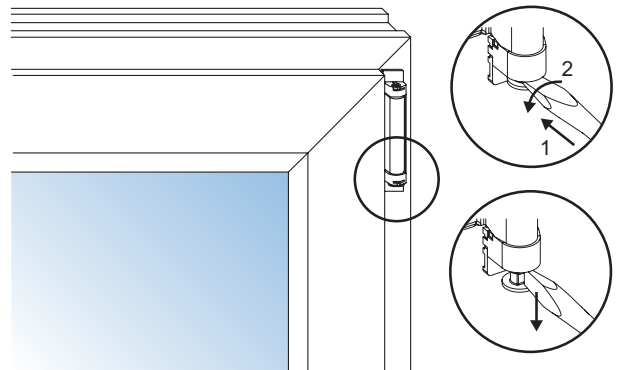

13.3



Please note! Damage to shear hinge. In case of improper use and if you attempt to drive out the pin forcibly, the scissor stay will be damaged. Use only a screwdriver or pin-pulling device to release the pin as shown in the figure.

Support the sash!



In order to save the sash hinge and corner hinge from damage, sagging of the sash during assembly must be prevented (give horizontal support)!

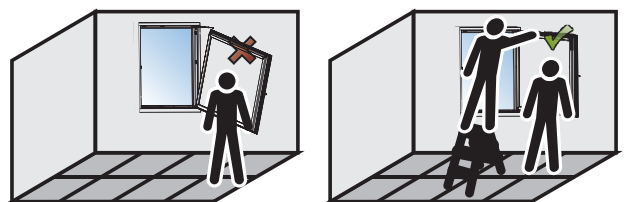

Important: Secure the window sash against falling. Take the heavy sash weight into account!

Notes on professional fitting and removing of sashes

Notes on professional mounting and dismounting of window sashes are given on our mounting advice. We recommend to place this mounting advice on the window sash.

i For withdrawing the shear hinge pin we recommend you to use the pulling device (see product page). If a screwdriver is used, please make sure that the powder coating of the hinge is not damaged.

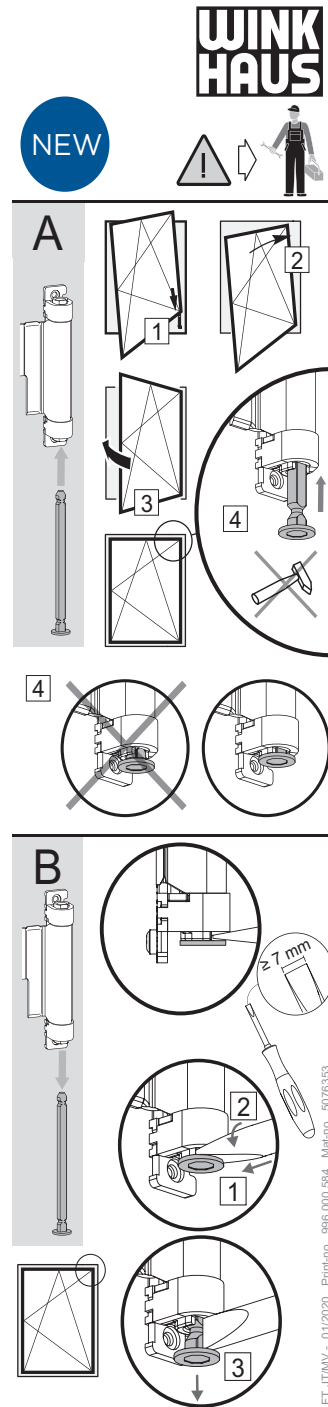

Installation of motor and base plate

The installation / disassembly of the fitting drive as well as the electrical connection are described in the original documentation HF.MD.PADM.01 and HF.PS.SNT1.U.24V.1A.

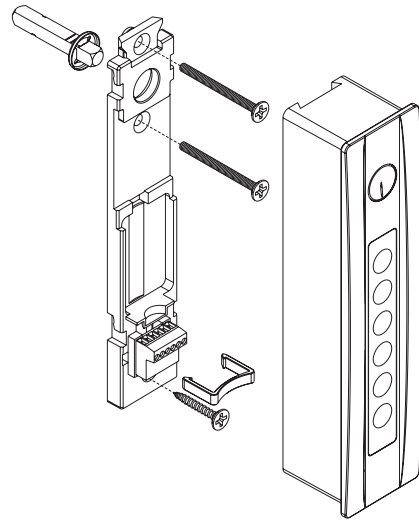

Operation / operating sequence

activPilot Comfort PADM

The opening positions are controlled by means of a motor drive.

activPilot Comfort PADM in combination with fitting drive HF.MD.PADM provides natural air exchange as per DIN 1946-6. As ventilation scenarios, such as preset ventilation times, can be set, indoor rooms can be supplied with natural fresh air independently of the user. To open the window fully, just press a button and the fittings motor drive releases the sash for the turn position. The window can then be opened manually as usual.

- You will find further information in the original operating instructions.



Mounting activities on the motorised window drive may only be performed by trained specialists!



The installation / disassembly of the fitting drive as well as the electrical connection are described in the original documentation HF.MD.PADM.01 and HF.PS.SNT1.U.24V.1A.

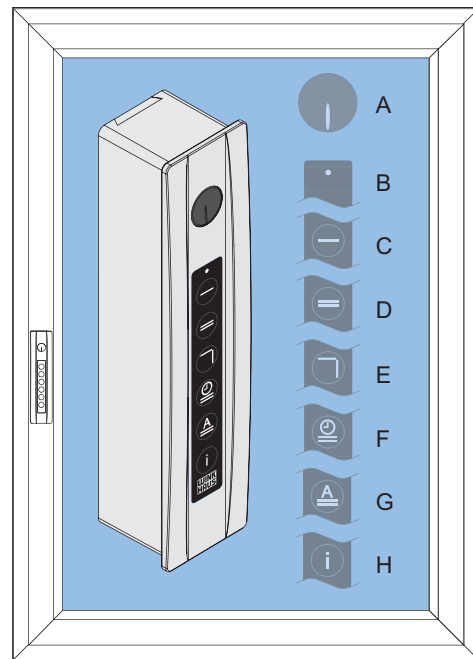

activPilot Comfort PADM - Operational elements

- A POSITION INDICATOR - shows the position of the fitting system
- B LED radio display - Each activation of the drive unit by means of the optional radio remote control is confirmed by a flashing light.
- C CLOSED - Press briefly to close the window.
- D OPEN in parallel position - Push briefly, the window moves into the parallel position.
- E OPEN in turn position - push for 1 sec , the drive unit moves the fitting in the turn position for manual opening as usual.
- F TIME VENTILATION - Briefly press 1 time, the drive moves to the parallel position. After a ventilation time of 10 minutes, it returns to the closed position. Pressing the button repeatedly increases the time by 10 minutes each time:
press 1 time: 10 minutes ventilation
press 2 times: 20 minutes ventilation
press 3 times: 30 minutes ventilation
- G AUTOMATIC/INTERVAL VENTILATION - Briefly pressing the Automatic button will activate the automatic/interval ventilation. This means that, in active state, ventilation takes place every hour for 10 minutes in the parallel position.
- H INFO - By briefly pressing the info button, the states are indicated with illuminated symbols in the dim mode for 20 sec.

Technology and function description

See figure: Function SBS.K.PAD

- If the octagonal locking bolt is in position 1, the window is locked.
- If the octagonal locking bolt is located in the centre (pos. 2) the window is opened 6 mm in the parallel position.
- If the octagonal bolt is in position 3, the window is wide open (turn position).

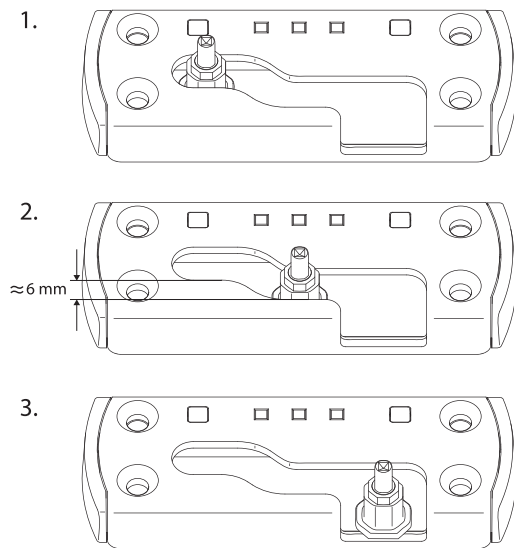

Function SBS.K.PAD

Operating and maintenance manual for the window company

General notes and safety advices

activPilot

These instructions are intended for the window company. They describe essential adjustment and maintenance work for activPilot fittings. Please observe the following notices: Fitting parts are to be tested regularly to ensure they are seated firmly and checked for wear. Fastening screws are to be retightened and parts replaced as necessary. Their functionality is to be retested afterwards. Fittings may only be cleaned with mild, ph-neutral cleaning agents in diluted form. Use only cleaning agents which do not degrade the corrosion protection on fitting parts. Never use aggressive, acidic or caustic cleaners, scouring agents or sharp objects to clean fitting parts. Always also observe the guideline for product specifications/notices and liability when making adjustments or performing maintenance.

This information can be obtained at the following Internet address:

<http://www.beschlagindustrie.de/ggsb/richtlinien.asp>

Adjustment options

Combination of corner hinge / sash hinge EL.C... and FL.C

Sash hinge without additional function

Sash hinge height adjustment (± 3 mm) and corner hinge side adjustment (± 2 mm) with 4 mm Allen key

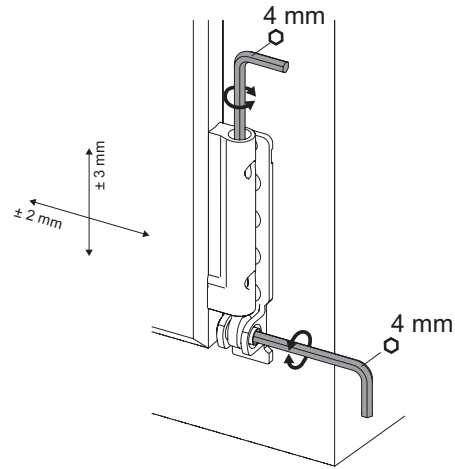

Sash hinge without additional function

Octagonal bolt

Regulate the contact pressure between the sash and the frame (± 0.8 mm) by turning the octagonal bolt. The adjustment can be carried out by means of the Winkhaus adjustment key (V.ST.SCH.HV-11).

When the fitting is moved from the open position to the parallel position, the fail safe device must be pressed.

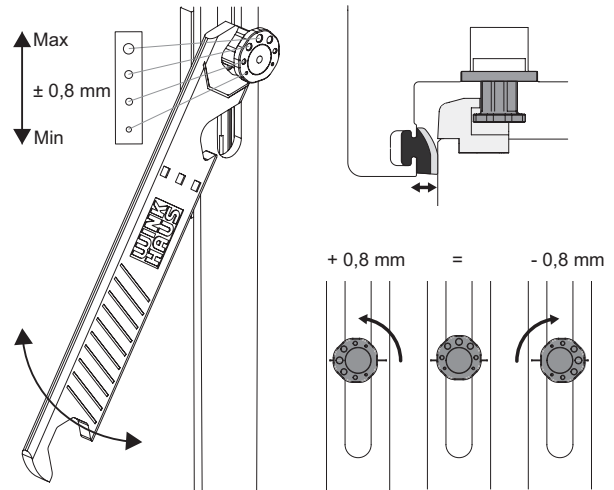

Shear - rectangular window

Lifting and lowering the sash by means of a 4 mm Allen key.

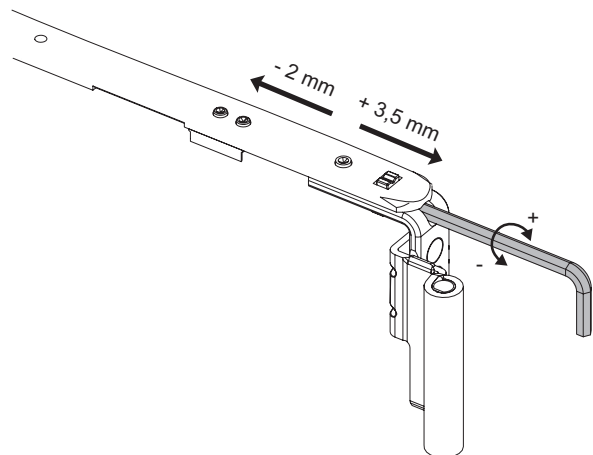

Shear - rectangular window

Maintenance

Lubrication points

See figure: Overview of lubrication points

The figure shows the location of possible lubrication points which should be lubricated at least once a year (every six months for school and hotel buildings).

Positions A, C, D = lubrication points relevant to function.

i Note: the fitting schematic shown adjacent does not necessarily match the existing fitting. The number of locking positions will vary depending on size and type of the window sash.

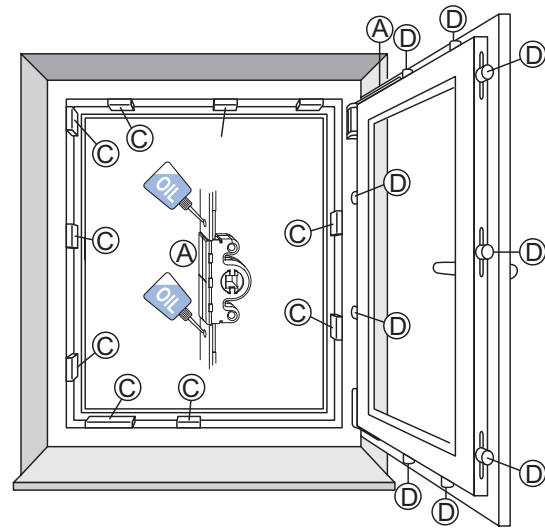

Overview of lubrication points

! Please note! Risk of injury. The window could fall on removal and thus injure persons. Do not remove the window for maintenance.

Ascertaining the run-in sides

See figure: Run-in sides

- Left-handed window; handle right
- Right-handed window; handle left

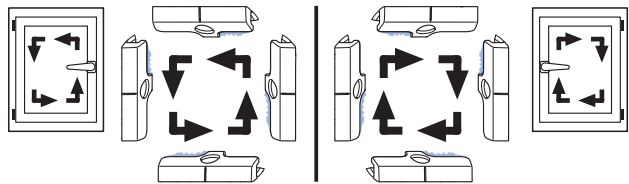

Run-in sides

Shears

See figure: Shears

All of the shear's contact points with the top rod should be oiled at least once annually.

i Note: The shear hinge must not be oiled or greased.

! Note: Please make sure the shear is clean in the upper area.

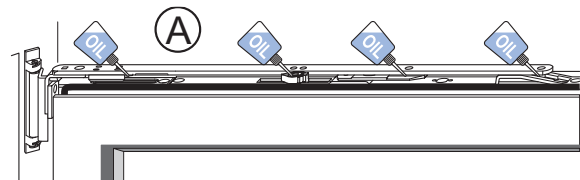

Shears

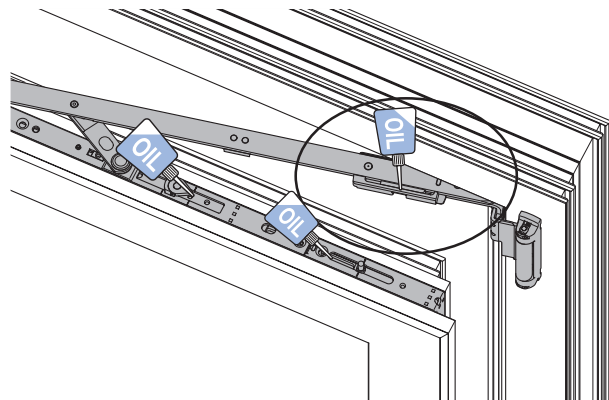

Protection from dirt and dust

Sash hinges

See figure: Sash hinges

All moving contact points on the sash hinge should be greased with a suitable lubricant once annually.

Coat lubricating points with non-resinous, non-corroding grease.

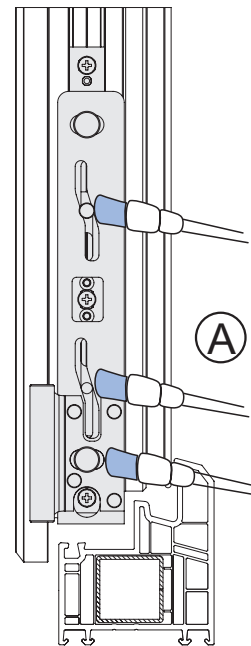

Sash hinges

Locking keeps

See figure: Locking keeps

To keep fittings running smoothly, you must lubricate the keeps at least once a year.

- Lubricate the keeps (C) at the run-in side with technical Vaseline or any other suitable grease.
- Coat the running surfaces of the locking bolts (D) with an oil that is free of resins and acids.
- Frame parts must be kept clean.

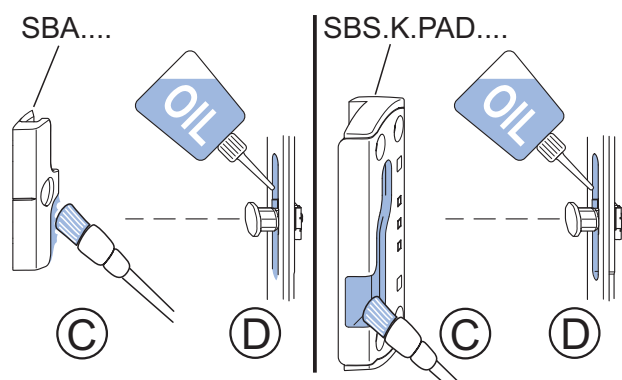

Locking keeps

Installation drawings

Drive rods

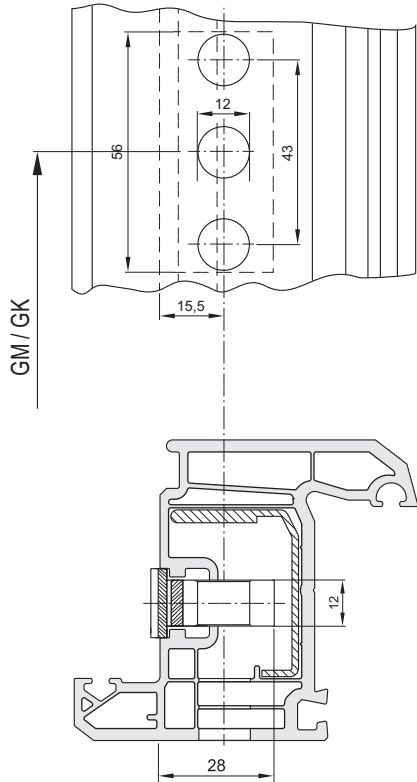

B-3-1: Drilling and milling template GAK/GAM ... D = 15.5 mm

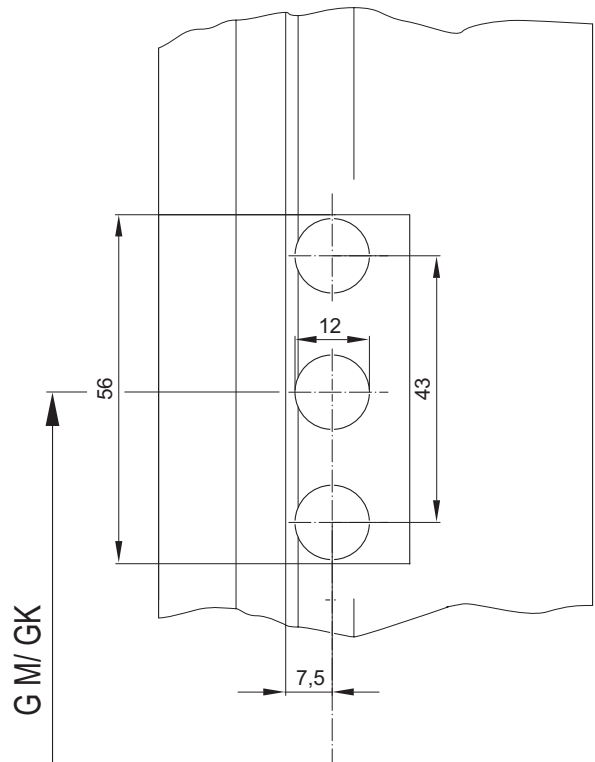

B-3-2: Drilling and milling template GAK/GAM ... D = 7.5 mm

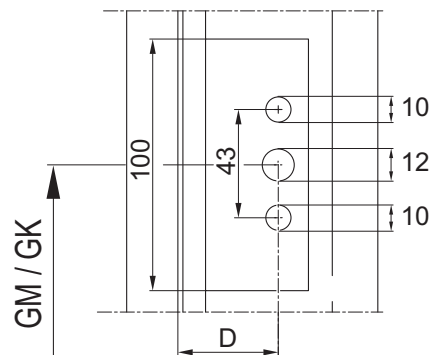

B-3-4: Drilling and milling template GAK/GAM ... D 25 ... 50
D = Backset

Corner hinge EL.CS and shear hinge SL.C

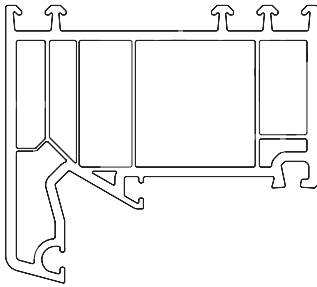

| | Ø(Z) [mm] | L [mm] |
|-----------|--------------|-----------|
| SL.C.3-3 | 3 | 3 |
| SL.C.3-6 | 6 | 3 |
| SL.C.22-6 | 6 | 22 |

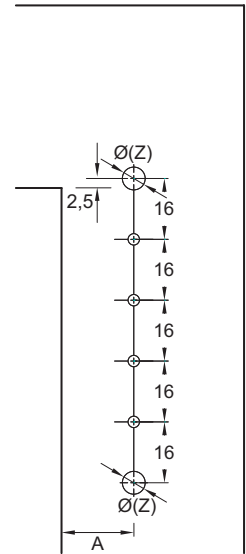
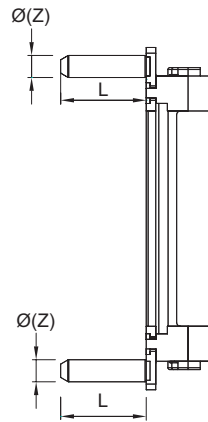
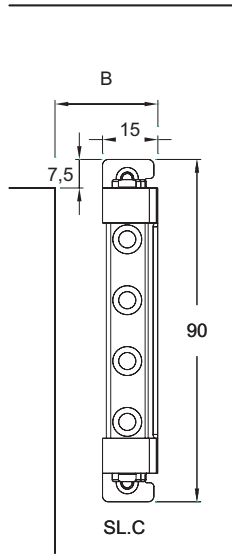

| UEB [mm] | A [mm] | B [mm] |
|-------------|-----------|-----------|
| 20 | 19 | 27 |
| 21 | 20 | 28 |
| 22 | 21 | 29 |

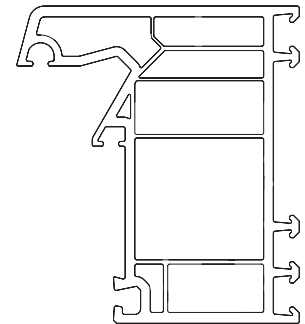

| | Ø(Z) [mm] | L(1) [mm] | L(2) [mm] |
|---------------|--------------|--------------|--------------|
| EL.CS.3-3-3 | 3 | 3 | 3 |
| EL.CS.6-3-3 | 6 | 3 | 3 |
| EL.CS.6-3-10 | 6 | 3 | 10 |
| EL.CS.6-3-22 | 6 | 3 | 22 |
| EL.CS.6-10-10 | 6 | 10 | 10 |
| EL.CS.6-22-3 | 6 | 22 | 3 |

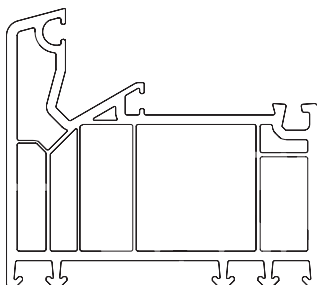
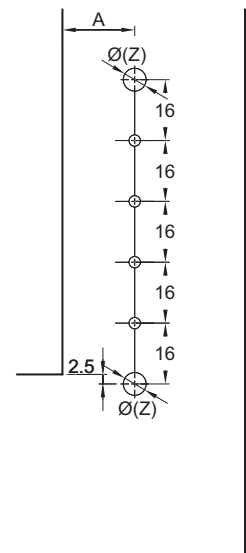
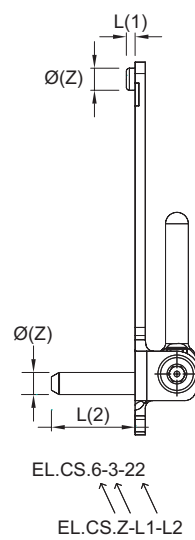
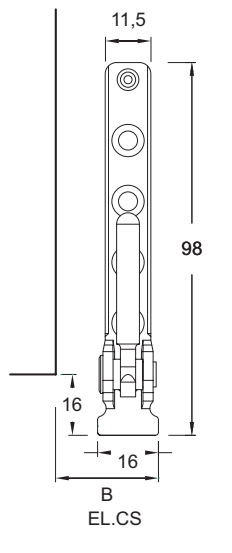

B-6-2: Drilling template shear hinge SL.C (top) corner hinge EL.CS (bottom)
UEB = overlap

Motor - base plate/cable outlet/cable installation



The installation / disassembly of the fitting drive as well as the electrical connection are described in the original documentation HF.MD.PADM.01 and HF.PS.SNT1.U.24V.1A.

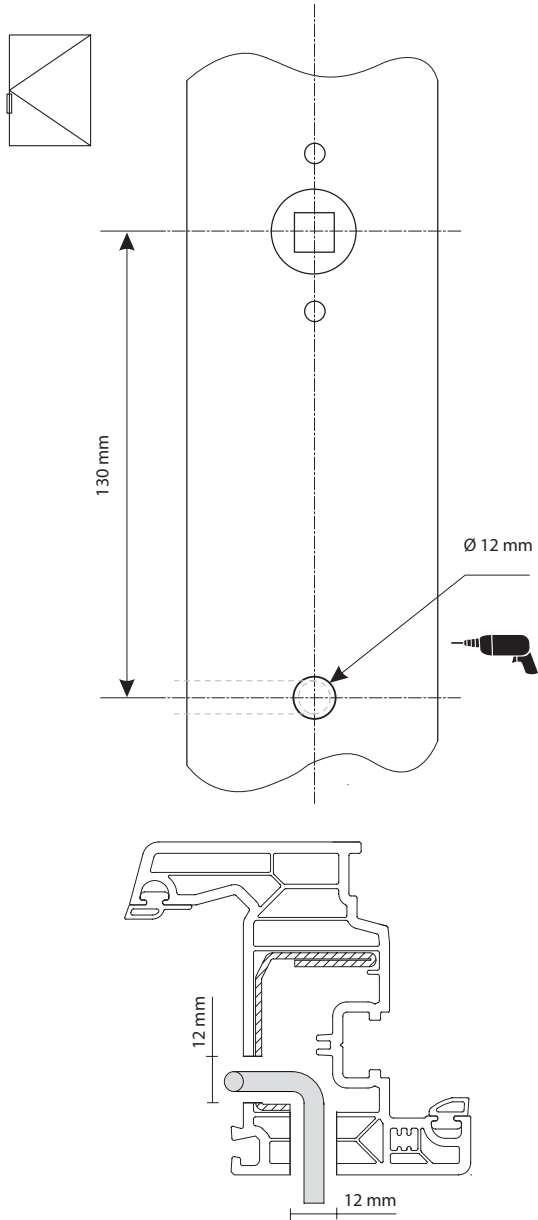

Cable transition KUE-T1

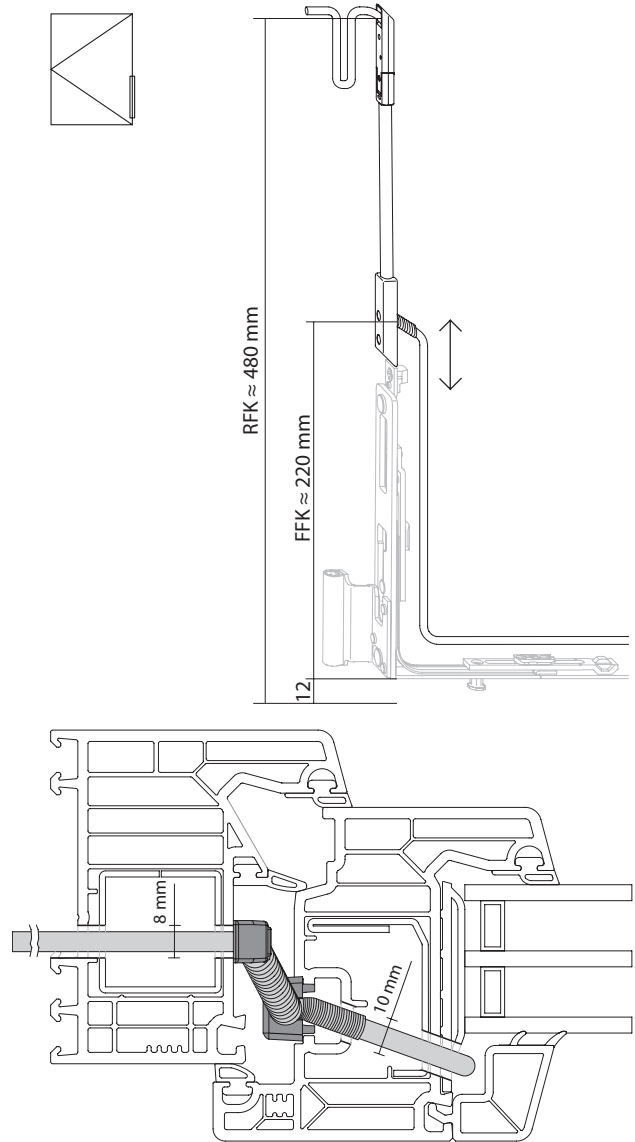

B-11-12: Installation drawing and cable laying Cable transition
 FFK = sash rebate edge
 RFK = frame rebate edge

| | | Page | |
|-----------|------------------------------------|-----------|-----------|
| 1 | General product information | 191 - 194 | 1 |
| 2 | Lists of Fittings | 195 - 209 | 2 |
| 3 | Drive rods | | 3 |
| 4 | Corner drives | | 4 |
| 5 | Top rods | | 5 |
| 6 | Sash hinges/Corner hinges | 210 - 213 | 6 |
| 7 | Shears/Shear hinges | 214 | 7 |
| 8 | Turn hinges/Tilt hinges | | 8 |
| 9 | Extension rods | | 9 |
| 10 | Accessories | | 10 |
| 11 | Frame parts | 215 | 11 |
| 12 | Mounting accessories | | 12 |
| 13 | Installation Instructions | 217 - 244 | 13 |
| 14 | Adjustment/maintenance | 245 - 248 | 14 |
| 15 | Installation drawings | 249 - 251 | 15 |
| 16 | activPilot Comfort PADM | 125 - 189 | 16 |
| 17 | activPilot Comfort PADS | 191 - 252 | 17 |
| 18 | activPilot Comfort PAD | 253 - 313 | 18 |

activPilot Comfort PADS

The turn fitting system for special window types

Arch windows, studio windows and triangle windows all have an identical fitting structure for the hinge and bottom side. With these window shapes, the parallel action shear is positioned horizontally.

Benefit for the window manufacturer: less items for the production of special windows are needed.

The PADS fitting system has rounded off the comprehensive range of parallel action fittings. With the exception of a few special components, the fitting parts are identical to the standard parts from the activPilot Concept fitting and the frame parts are the same as those used in the activPilot Comfort PADK. This means that the PADS fitting also follows the basic principle of the activPilot fitting system: a small number of individual components with a variety of different uses.

The window manufacturer benefits from the fact that time-consuming processing of the frame rebate in the shear area is not required for angled windows. The sash and frame rebate often touch during tilt opening, which then has to be rectified with manual reworking of the frame rebate edge. Parallel action can remove the need for this profile-related additional work. This proves just how easy to fit the activPilot fitting is.

The benefits of parallel action with regard to both control and ventilation, which are familiar from the PADK and PADM product segments, also apply for the PADS fitting. An approx. 6 mm wide circumferential ventilation gap provides a pleasant, draught-free air exchange, improves the room climate, helps prevent damage caused by damp and also helps to save on heating energy. For the end consumer, this offers improved comfort levels compared with ventilation via tilted windows.

Parallel action windows are also preferable to tilt and turn windows from the point of view of monument conservation. In contrast to tilt-open sashes, the look of a historic facade is not destroyed by a parallel action window, as the opening gap cannot be seen from the outside.

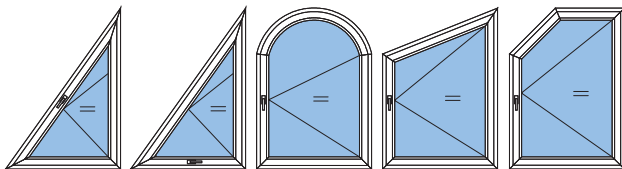

activPilot Comfort PADS

Application diagram for ascertaining the admissible sash sizes

- Max. sash weight 100 kg

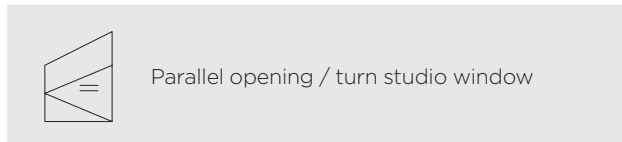
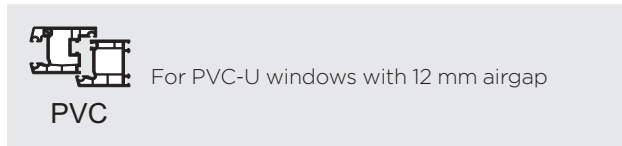

Width-to-height ratio and additional load

Value calculated without additional load for a width-to-height ratio of 1:1.

The application graphs have been calculated without additional loads. Please consult your Winkhaus contact person for further information on how to calculate the maximum permissible window sash format with an additional load.

Advice for use

The application range permitted for using Winkhaus fitting is highlighted in grey in the application graphs. However, it is essential not to use the entire grey-highlighted section, but only those parts which are on the left-hand side of the curve for the respective GG filling weight.

Application range

The respective overall fitting must be selected from the original Winkhaus activPilot fitting components range. Winkhaus accepts no liability if non-original or unauthorised system accessory parts are used.

- Min. sash rebate width 460 mm
- Max. sash rebate width 1250 mm
- Min. sash rebate height 610 mm
- Max. sash rebate height 2300 mm
- Max. sash size 2.0 m²
- Max. sash weight 100 kg
- 1 mm glass ≈ 2.5 kg/m²
- Ratio between sash rebate width: Sash rebate height ≤ 1 : 1



Note: From sash weights of 40 kg the filling must be bonded to the sash all around the window.

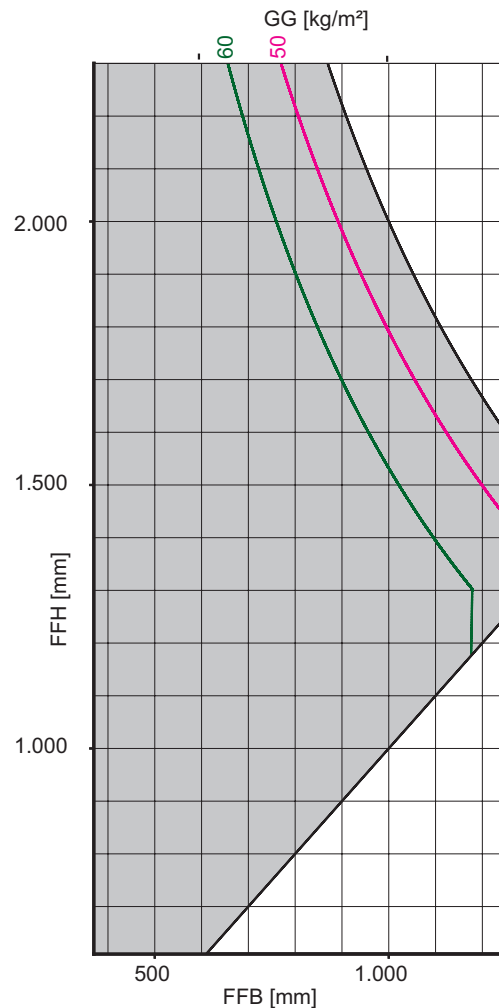

AWD_01.50_NR110_DK_100 kg_ohne_Zusatzlast_1,5_m_AT

Abbreviations

- FFB = Sash rebate width [mm]
- FFH = Sash rebate height [mm]
- GG = Glass weight per square metre [kg/m²]

Observe instructions on window profile

You must specifically take into account information provided by the profile manufacturer or system owner when determining the maximum sash sizes and sash weights!



Important: The screw connections of the load-bearing fitting components, such as corner, shear and sash hinges must be performed according to the TBDK guidelines. Adapt the drilling diameter for the fixing screws, the screw diameter and the screw length to the load situation.



Note: activPilot Comfort fittings are not suitable for use in panic doors! They are not recommended for passage doors.

1

activPilot Comfort PADS

Application diagram for ascertaining the admissible sash sizes

- Max. sash weight 100 kg

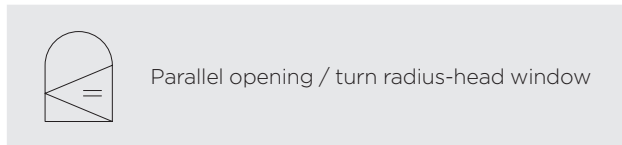
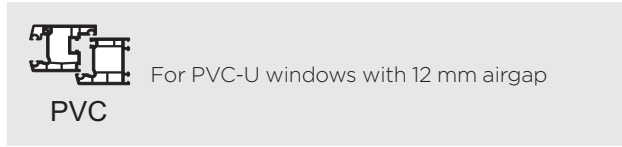

Width-to-height ratio and additional load

Value calculated without additional load for a width-to-height ratio of 1:1.

The application graphs have been calculated without additional loads. Please consult your Winkhaus contact person for further information on how to calculate the maximum permissible window sash format with an additional load.

Advice for use

The application range permitted for using Winkhaus fitting is highlighted in grey in the application graphs. However, it is essential not to use the entire grey-highlighted section, but only those parts which are on the left-hand side of the curve for the respective GG filling weight.

Application range

The respective overall fitting must be selected from the original Winkhaus activPilot fitting components range. Winkhaus accepts no liability if non-original or unauthorised system accessory parts are used.

- Min. sash rebate width 460 mm
- Max. sash rebate width 1250 mm
- Min. sash rebate height 610 mm
- Max. Sash rebate height 1800 mm (FFH-R)
- Max. sash size 2.0 m²
- Max. sash weight 100 kg
- 1 mm glass ≈ 2.5 kg/m²
- Ratio between sash rebate width: Sash rebate height ≤ 1 : 1

i Note: From sash weights of 40 kg the filling must be bonded to the sash all around the window.

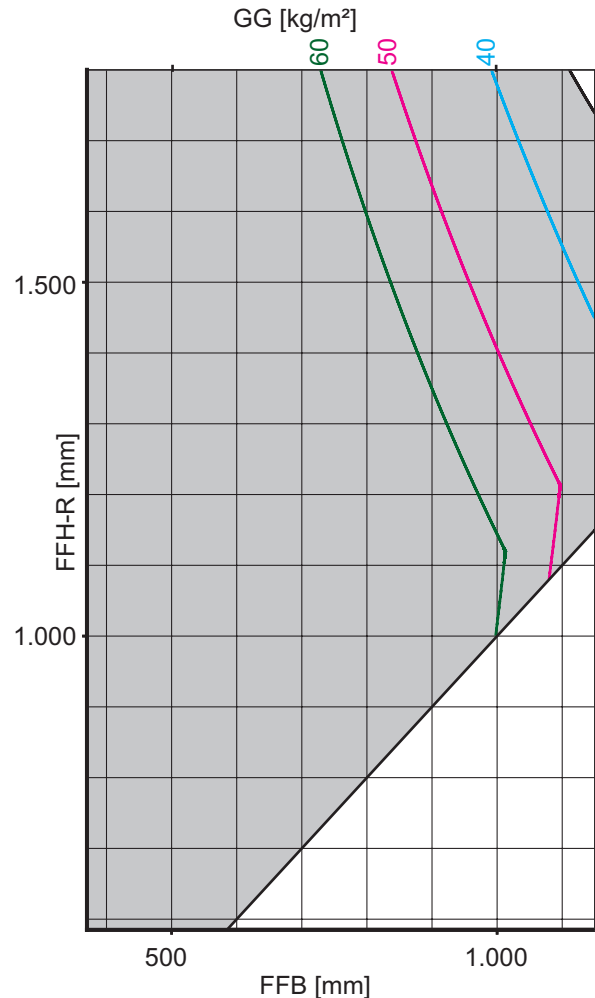

Abbreviations

- FFB = Sash rebate width [mm]
- FFH = Sash rebate height [mm]
- GG = Glass weight per square metre [kg/m²]

Observe instructions on window profile

You must specifically take into account information provided by the profile manufacturer or system owner when determining the maximum sash sizes and sash weights!



Important: The screw connections of the load-bearing fitting components, such as corner, shear and sash hinges must be performed according to the TBDK guidelines. Adapt the drilling diameter for the fixing screws, the screw diameter and the screw length to the load situation.



Note: activPilot Comfort fittings are not suitable for use in panic doors! They are not recommended for passage doors.

Quick orientation

Our register system allows you to quickly allocate the listed component to the item in the fitting overview drawing. The item number specifies the chapter number in which the component can be found.

4.2
AARB1000-3

activPilot Comfort PADS

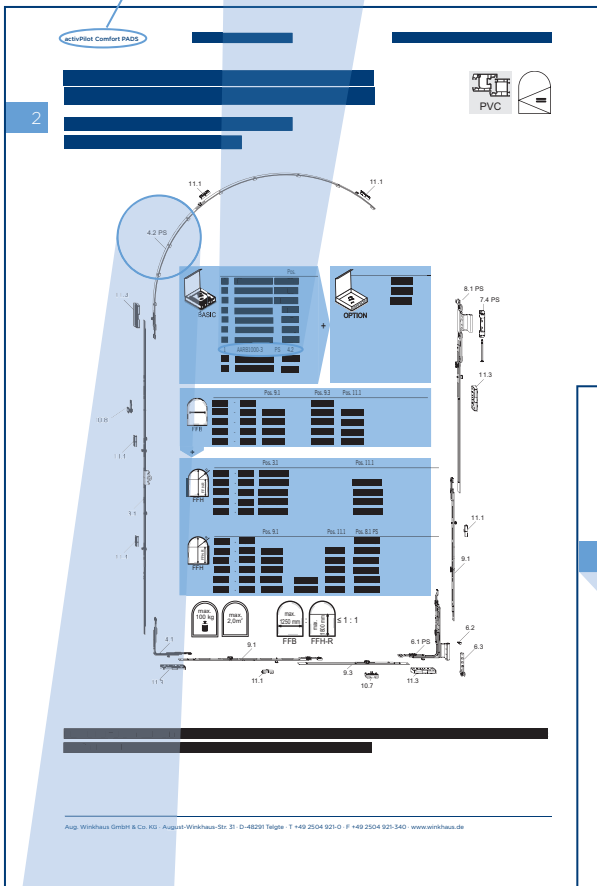

4.2

activPilot Comfort PADS

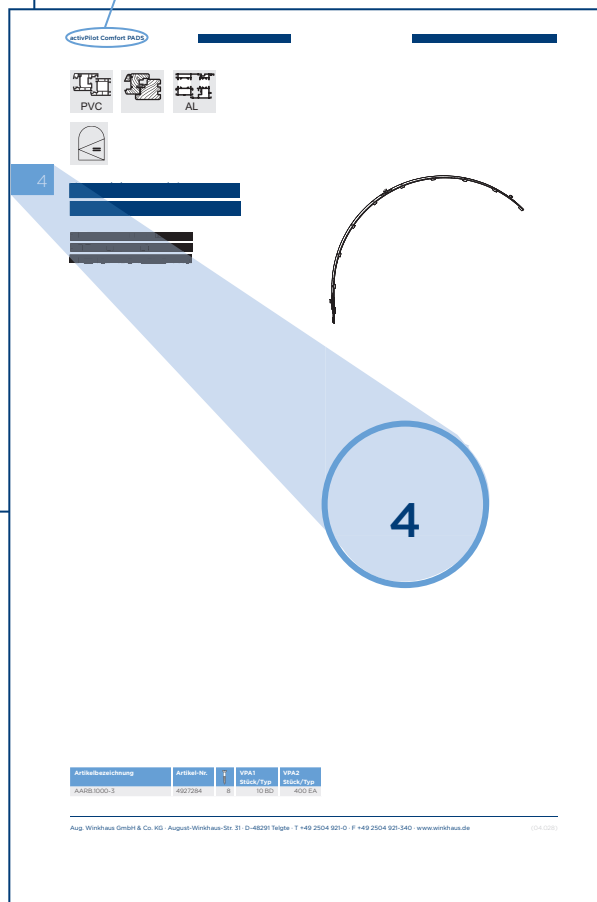

4

| Artikelbezeichnung | Artikel-Nr. | 1 | VPA1 | VPA2 |
|--------------------|-------------|---|-----------|-----------|
| AARB1000-3 | 492784 | 1 | Stück/73p | Stück/73p |
| | | | 10.020 | 1000.020 |

Lists of Fittings

| | |
|--|-----|
| Turn fitting system – constant handle position Basic equipment for studio windows activPilot Comfort PADS | 198 |
| Turn fitting system – central handle position Basic equipment for studio windows activPilot Comfort PADS | 200 |
| Turn fitting system – constant handle position Basic equipment for round-arch windows activPilot Comfort PADS | 202 |
| Turn fitting system – central handle position Basic equipment for round-arch windows activPilot Comfort PADS | 204 |
| Turn fitting system – central handle position Basic equipment for triangle windows – slanted handle position activPilot Comfort PADS | 206 |
| Turn fitting system – central handle position Basic equipment for triangle windows – bottom handle position activPilot Comfort PADS | 208 |

Turn fitting system - constant handle position

Basic equipment for studio windows
activPilot Comfort PADS

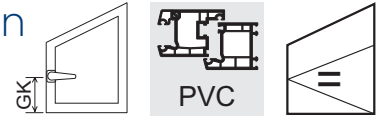

2

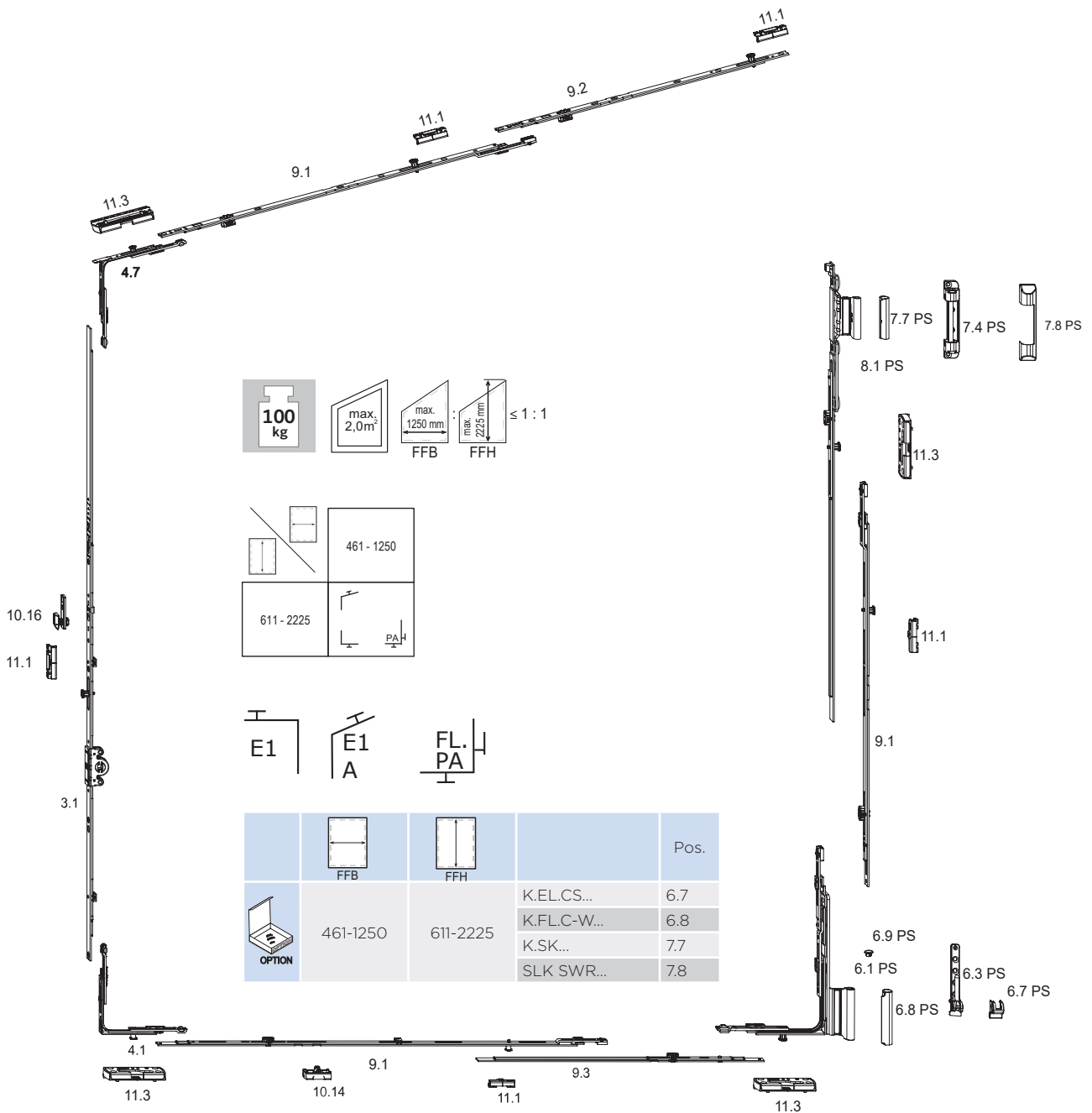

You will find the components marked PS on the following pages. All other parts can be found in the activPilot Comfort PADK section.









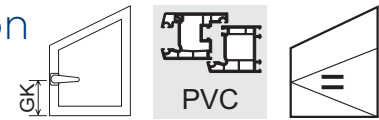

The shown distance between locking points is 800 mm.

The locking distances must be agreed with the system provider.

Turn fitting system - constant handle position

Basic equipment for studio windows









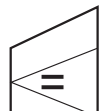
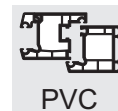
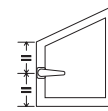



| |  |  | | Pos. | | Pos. | | Pos. | | Pos. | |
|---|---|---|--------------|-------|----------|-------|--------------|----------|--------------|------|----|
|  | 461-1250 | 611-700 | GAK.710 | 3.1 | | | GK = 210 | | | | |
| | | 701-850 | GAK.945-1 | 3.1 | FSF | 10.16 | GK = 260 | | SBA.K... | 11.1 | 1x |
| | | 851-1100 | GAK.1100-1 | 3.1 | FSF | 10.16 | GK = 375 | | SBA.K... | 11.1 | 1x |
| | | 1101-1325 | GAK.1325-1 | 3.1 | FSF | 10.16 | GK = 550 | | SBA.K... | 11.1 | 1x |
| | | 1326-1550 | GAK.1550-1 | 3.1 | FSF | 10.16 | GK = 550 | | SBA.K... | 11.1 | 1x |
| | | 1551-1775 | GAK.1775-2 | 3.1 | FSF | 10.16 | GK = 550 | | SBA.K... | 11.1 | 2x |
| | | 1776-2000 | GAK.2000-2 | 3.1 | FSF | 10.16 | GK = 1050 | | SBA.K... | 11.1 | 2x |
| | | 2001-2225 | GAK.2225-2 | 3.1 | FSF | 10.16 | GK = 1050 | | SBA.K... | 11.1 | 2x |
|  | 461-1250 | 611-2225 | E1.A | 4.7 | | | | | SBS...PAB... | 11.3 | 1x |
|  | 461-555 | 611-2225 | M.250-1 | 9.2 | | | | | SBA.K... | 11.1 | 1x |
| | 556-805 | | M.500-1 | 9.2 | | | | | SBA.K... | 11.1 | 1x |
| | 806-1055 | | M.750-1 | 9.2 | | | | | SBA.K... | 11.1 | 1x |
| | 1056-1250 | | MK.500-1 | 9.1 | M.500-1 | 9.2 | | | SBA.K... | 11.1 | 2x |
|  | 461-1250 | 611-2225 | SL SWR... | 7.4 | | | DL.K.PADS... | 8.1 | SBS...PAB... | 11.3 | 1x |
|  | 461-1250 | 861-1110 | MK.250-1 | 9.1 | | | | | SBA.K... | 11.1 | 1x |
| | | 1111-1360 | MK.500-1 | 9.1 | | | | | SBA.K... | 11.1 | 1x |
| | | 1361-1610 | MK.750-1 | 9.1 | | | | | SBA.K... | 11.1 | 1x |
| | | 1611-1860 | MK.500-1 | 9.1 | MK.500-1 | 9.1 | | | SBA.K... | 11.1 | 2x |
| | | 1861-2110 | MK.500-1 | 9.1 | MK.750-1 | 9.1 | | | SBA.K... | 11.1 | 2x |
| | | 2111-2225 | MK.750-1 | 9.1 | MK.750-1 | 9.1 | | SBA.K... | 11.1 | 2x | |
|  | 461-1250 | 611-2225 | FL.C.PADS... | 6.1 | EL.CS... | 6.3 | | | SBS...PAB... | 11.3 | 1x |
| | | | S.FL.C-W... | 6.9 | | | | | | | |
|  | 461-710 | 611-2225 | KE SL | 9.3 | AL.M... | 10.14 | AL.M... | 10.14 | | | |
| | 711-960 | | KE SL | 9.3 | AL.M... | 10.14 | MK.250-1 | 9.1 | SBA.K... | 11.1 | 1x |
| | 961-1210 | | AL.M... | 10.14 | | | | | | | |
| | | | KE SL | 9.3 | AL.M... | 10.14 | MK.500-1 | 9.1 | SBA.K... | 11.1 | 1x |
| 1211-1250 | AL.M... | 10.14 | | | | | | | | | |
| | | | KE SL | 9.3 | AL.M... | 10.14 | MK.750-1 | 9.1 | SBA.K... | 11.1 | 1x |
| | | | AL.M... | 10.14 | | | | | | | |
|  | 461-1250 | 611-2225 | E1 | 4.1 | | | | | SBS...PAB... | 11.3 | 1x |

Turn fitting system - central handle position

Basic equipment for studio windows



| |  |  | | Pos. | | Pos. | | Pos. | | Pos. | | |
|---|---|---|--------------|-------|----------|-------|--------------|-------|--------------|------|----|--|
|  | 461-1250 | 611-710 | GAM.800 | 3.1 | | | | | | | | |
| | | 711-980 | GAM.1050-1 | 3.1 | FSF | 10.16 | | | SBA.K... | 11.1 | 1x | |
| | | 981-1400 | GAM.1400-1 | 3.1 | FSF | 10.16 | | | SBA.K... | 11.1 | 1x | |
| | | 1401-1800 | GAM.1800-2 | 3.1 | FSF | 10.16 | | | SBA.K... | 11.1 | 2x | |
| | | 1801-2300 | GAM.2300-3 | 3.1 | FSF | 10.16 | | | SBA.K... | 11.1 | 3x | |
|  | 461-1250 | 611-2300 | E1.A | 4.7 | | | | | SBS...PAB... | 11.3 | 1x | |
|  | 461-555 | 611-2300 | M.250-1 | 9.2 | | | | | SBA.K... | 11.1 | 1x | |
| | 556-805 | | M.500-1 | 9.2 | | | | | SBA.K... | 11.1 | 1x | |
| | 806-1055 | | M.750-1 | 9.2 | | | | | SBA.K... | 11.1 | 1x | |
| | 1056-1250 | | MK.500-1 | 9.1 | M.500-1 | 9.2 | | | SBA.K... | 11.1 | 2x | |
|  | 461-1250 | 611-2300 | SL SWR... | 7.4 | | | DL.K.PADS... | | SBS...PAB... | 11.3 | 1x | |
|  | 461-1250 | 861-1110 | MK.250-1 | 9.1 | | | | | SBA.K... | 11.1 | 1x | |
| | | 1111-1360 | MK.500-1 | 9.1 | | | | | SBA.K... | 11.1 | 1x | |
| | | 1361-1610 | MK.750-1 | 9.1 | | | | | SBA.K... | 11.1 | 1x | |
| | | 1611-1860 | MK.500-1 | 9.1 | MK.500-1 | 9.1 | | | SBA.K... | 11.1 | 2x | |
| | | 1861-2110 | MK.500-1 | 9.1 | MK.750-1 | 9.1 | | | SBA.K... | 11.1 | 2x | |
| | | 2111-2300 | MK.750-1 | 9.1 | MK.750-1 | 9.1 | | | SBA.K... | 11.1 | 2x | |
|  | 461-1250 | 611-2300 | FL.C.PADS... | 6.1 | EL.CS... | 6.3 | | 8.1 | SBS...PAB... | 11.3 | 1x | |
| | | | S.FL.C-W... | 6.9 | | | | | | | | |
|  | 461-710 | 611-2300 | KE SL | 9.3 | AL.M... | 10.14 | AL.M... | 10.14 | | | | |
| | 711-960 | | KE SL | 9.3 | AL.M... | 10.14 | MK.250-1 | 9.1 | SBA.K... | 11.1 | 1x | |
| | 961-1210 | | AL.M... | 10.14 | | | | | | | | |
| | | | KE SL | 9.3 | AL.M... | 10.14 | MK.500-1 | 9.1 | SBA.K... | 11.1 | 1x | |
| | 1211-1250 | | AL.M... | 10.14 | | | | | SBA.K... | 11.1 | 1x | |
|  | 461-1250 | 611-2300 | E1 | 4.1 | | | | | SBS...PAB... | 11.3 | 1x | |

Turn fitting system - constant handle position

Basic equipment for radius-head windows
activPilot Comfort PADS

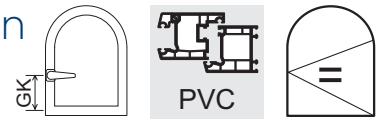

2

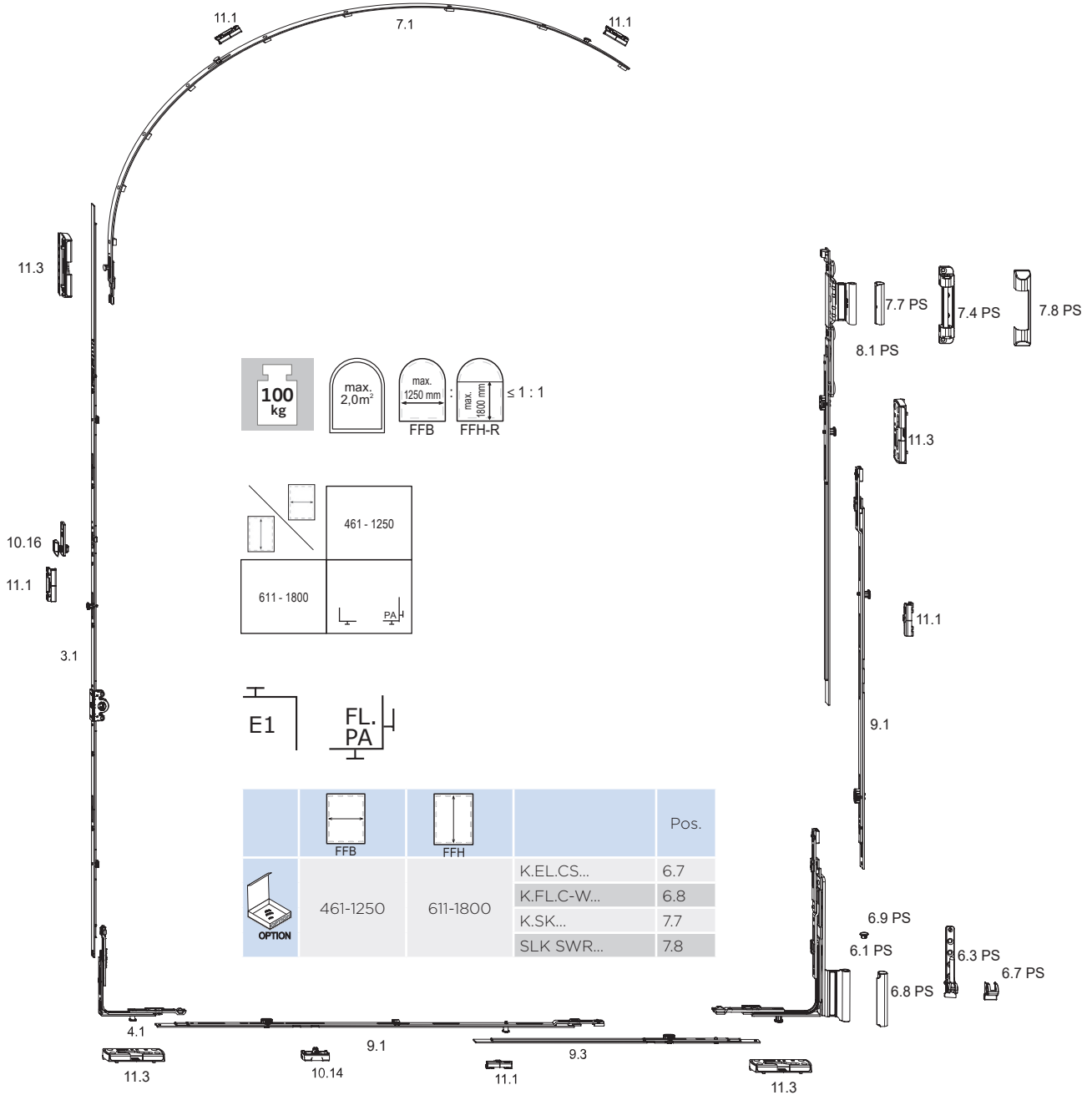

You will find the components marked PS on the following pages. All other parts can be found in the activPilot Comfort PADK section.









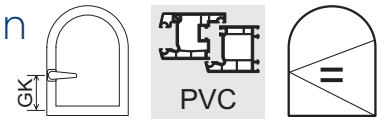

The shown distance between locking points is 800 mm.

The locking distances must be agreed with the system provider.

Turn fitting system - constant handle position

Basic equipment for radius-head windows









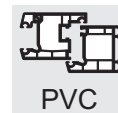
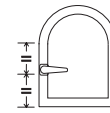

| |  |  | | Pos. | | Pos. | | Pos. | | Pos. | | | |
|---|---|---|--------------|------------|-----|----------|-------|--------------|-----|--------------------------|--------------|----------|----|
|  | 461-1250 |  | 611-700 | GAK.710 | 3.1 | | | GK = 210 | | | | | |
| | | | 701-850 | GAK.945-1 | 3.1 | FSF | 10.16 | GK = 260 | | SBA.K... | 11.1 | 1x | |
| | | | 851-1100 | GAK.1100-1 | 3.1 | FSF | 10.16 | GK = 375 | | SBA.K... | 11.1 | 1x | |
| | | | 1101-1325 | GAK.1325-1 | 3.1 | FSF | 10.16 | GK = 550 | | SBA.K... | 11.1 | 1x | |
| | | | 1326-1550 | GAK.1550-1 | 3.1 | FSF | 10.16 | GK = 550 | | SBA.K... | 11.1 | 1x | |
| | | | 1551-1775 | GAK.1775-2 | 3.1 | FSF | 10.16 | GK = 550 | | SBA.K... | 11.1 | 2x | |
| | | | 1776-1800 | GAK.2000-2 | 3.1 | FSF | 10.16 | GK = 1050 | | SBA.K... | 11.1 | 2x | |
|  | 461-1250 | 611-1800 | AARB.1000-3 | 7.1 | | | | | | SBS...PAB... SBA.K... | 11.3 11.1 | 1x 2x | |
|  | 461-1250 | 611-1800 | SL SWR... | 7.4 | | | | | | | | | |
|  | 461-1250 |  | 861-1110 | MK.250-1 | 9.1 | | | | | SBA.K... | 11.1 | 1x | |
| | | | 1111-1360 | MK.500-1 | 9.1 | | | | | SBA.K... | 11.1 | 1x | |
| | | | 1361-1610 | MK.750-1 | 9.1 | | | | | | SBA.K... | 11.1 | 1x |
| | | | 1611-1800 | MK.500-1 | 9.1 | MK.500-1 | 9.1 | | | | SBA.K... | 11.1 | 2x |
|  | 461-1250 | 611-1800 | FL.C.PADS... | | 6.1 | EL.CS... | 6.3 | DL.K.PADS... | 8.1 | SBS...PAB... | 11.3 | 2x | |
| | | | S.FL.C-W... | | 6.9 | | | | | | | | |
|  | 461-710 | 611-1800 | KE SL | | 9.3 | AL.M... | 10.14 | | | | | | |
| | 711-960 | | KE SL | | 9.3 | AL.M... | 10.14 | MK.250-1 | 9.1 | SBA.K... | 11.1 | 1x | |
| | 961-1210 | | KE SL | | 9.3 | AL.M... | 10.14 | MK.500-1 | 9.1 | SBA.K... | 11.1 | 1x | |
| | 1211-1250 | | KE SL | | 9.3 | AL.M... | 10.14 | MK.750-1 | 9.1 | SBA.K... | 11.1 | 1x | |
|  | 461-1250 | 611-1800 | E1 | | 4.1 | | | | | SBS...PAB... | 11.3 | 1x | |

Turn fitting system - central handle position

Basic equipment for radius-head windows



2

| |  |  | | Pos. | | Pos. | | Pos. | | Pos. | |
|---|---|---|--------------|------|----------|-------|--------------|------|--------------------------|--------------|----------|
|  | 461-1250 | 611-710 | GAM.800 | 3.1 | | | | | | | |
| | | 711-980 | GAM.1050-1 | 3.1 | FSF | 10.16 | | | SBA.K... | 11.1 | 1x |
| | | 981-1400 | GAM.1400-1 | 3.1 | FSF | 10.16 | | | SBA.K... | 11.1 | 1x |
| | | 1401-1800 | GAM.1800-2 | 3.1 | FSF | 10.16 | | | SBA.K... | 11.1 | 2x |
|  | 461-1250 | 611-1800 | AARB.1000-3 | 7.1 | | | | | SBS...PAB... SBA.K... | 11.3 11.1 | 1x 2x |
|  | 461-1250 | 611-1800 | SL SWR... | 7.4 | | | | | | | |
|  | 461-1250 | 861-1110 | MK.250-1 | 9.1 | | | | | SBA.K... | 11.1 | 1x |
| | | 1111-1360 | MK.500-1 | 9.1 | | | | | SBA.K... | 11.1 | 1x |
| | | 1361-1610 | MK.750-1 | 9.1 | | | | | SBA.K... | 11.1 | 1x |
| | | 1611-1800 | MK.500-1 | 9.1 | MK.500-1 | 9.1 | | | SBA.K... | 11.1 | 2x |
|  | 461-1250 | 611-1800 | FL.C.PADS... | 6.1 | EL.CS... | 6.3 | DL.K.PADS... | 8.1 | SBS...PAB... | 11.3 | 2x |
| | | | S.FL.C-W... | 6.9 | | | | | | | |
|  | 461-710 | 611-1800 | KE SL | 9.3 | AL.M... | 10.14 | | | | | |
| | 711-960 | | KE SL | 9.3 | AL.M... | 10.14 | MK.250-1 | 9.1 | SBA.K... | 11.1 | 1x |
| | 961-1210 | | KE SL | 9.3 | AL.M... | 10.14 | MK.500-1 | 9.1 | SBA.K... | 11.1 | 1x |
| | 1211-1250 | | KE SL | 9.3 | AL.M... | 10.14 | MK.750-1 | 9.1 | SBA.K... | 11.1 | 1x |
|  | 461-1250 | 611-1800 | E1 | 4.1 | | | | | SBS...PAB... | 11.3 | 1x |

Turn fitting system - central handle position

Basic equipment for triangle windows - slanted handle position
 activPilot Comfort PADS

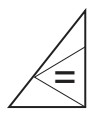
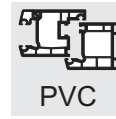

2

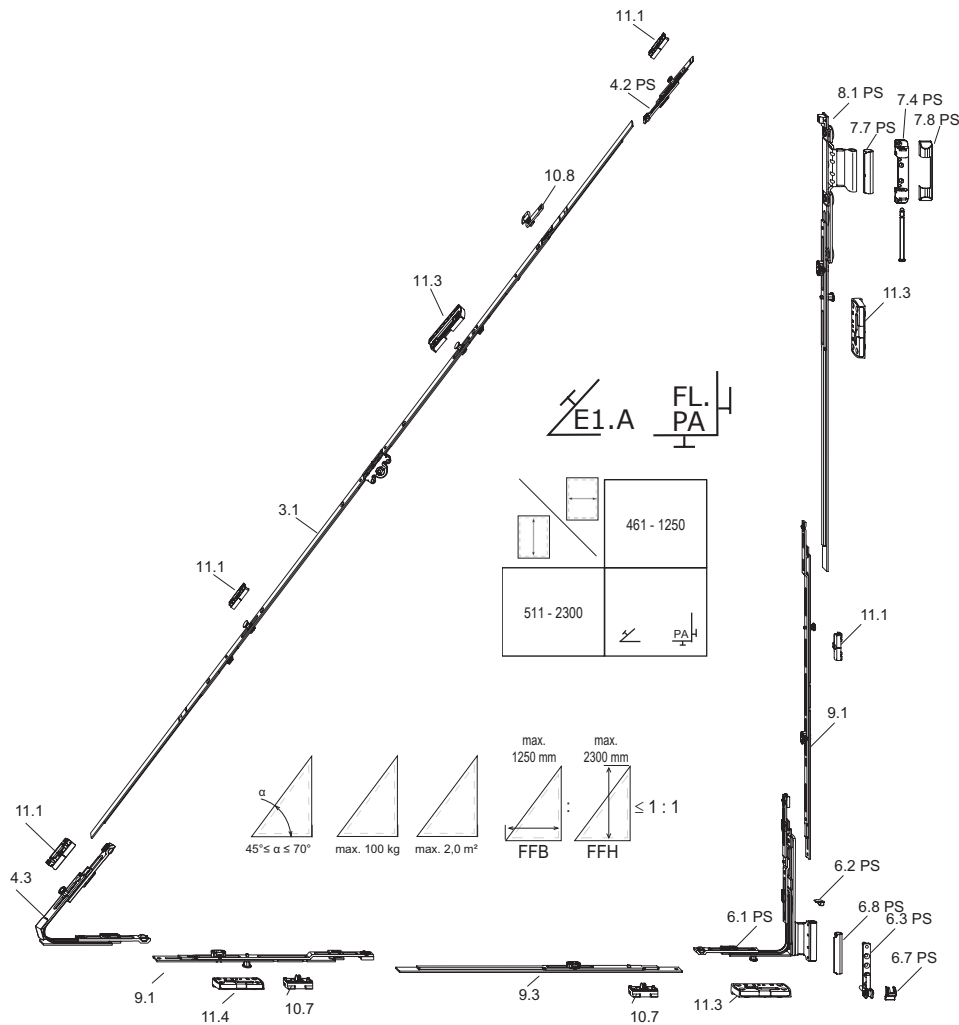

| | | | | Pos. |
|--|----------|----------|------------|------|
| | 461-1250 | 611-2300 | K.ELCS... | 6.7 |
| | | | K.FLC-W... | 6.8 |
| | | | K.SK... | 7.7 |
| | | | SLK SWR... | 7.8 |

You will find the components marked PS on the following pages. All other parts can be found in the activPilot Comfort PADK section.

The shown distance between locking points is 800 mm.







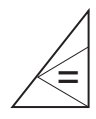
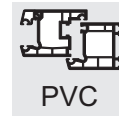
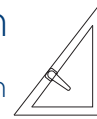

The locking distances must be agreed with the system provider.

Turn fitting system - central handle position

Basic equipment for triangle windows - slanted handle position



2

| |  |  | | Pos. | | Pos. | | Pos. | | Pos. | |
|---|---|---|------------------|-------------|-----------|--------|-------------|------|-------------------------|--------------|----------|
|  | 461-1250 | 611-710 | GAM.800 | 3.1 | | | ASS.AS.1 | 4.1 | SBA.K... | 11.1 | 1x |
| | | 711-980 | GAM.1050-1 | 3.1 | FSF | 10.16 | ASS.AS.1 | 4.1 | SBA.K... SBS. PAB... | 11.1 11.3 | 1x 1x |
| | | 981-1400 | GAM.1400-1 | 3.1 | FSF | 10.16 | ASS.AS.1 | 4.1 | SBA.K... SBS. PAB... | 11.1 11.3 | 1x 1x |
| | | 1401-1800 | GAM.1800-2 | 3.1 | FSF | 10.16 | ASS.AS.1 | 4.1 | SBA.K... SBS. PAB... | 11.1 11.3 | 2x 1x |
| | | 1801-2300 | GAM.2300-3 | 3.1 | FSF | 10.16 | ASS.AS.1 | 4.1 | SBA.K... SBS. PAB... | 11.1 11.3 | 3x 1x |
|  | 461-1250 | 611-2300 | DL.K.PADS... | 8.1 PS | SL SWR... | 7.4 PS | | | SBS...PAB | 11.3 | 1x |
|  | 461-1250 | 861-1110 | MK.250-1 | 9.1 | | | | | SBA.K... | 11.1 | 1x |
| | | 1111-1360 | MK.500-1 | 9.1 | | | | | SBA.K... | 11.1 | 1x |
| | | 1361-1610 | MK.750-1 | 9.1 | | | | | SBA.K... | 11.1 | 1x |
| | | 1611-1800 | MK.500-1 | 9.1 | MK.500-1 | 9.1 | | | SBA.K... | 11.1 | 2x |
| | | 1801-2110 | MK.500-1 | 9.1 | MK.750-1 | 9.1 | | | SBA.K... | 11.1 | 2x |
| | | 2111-2300 | MK.750-1 | 9.1 | MK.750-1 | 9.1 | | | SBA.K... | 11.1 | 2x |
|  | 461-1250 | 611-2300 | FL.C.PADS... | 6.1 PS | EL.CS... | 6.3 | S.FL.C-W... | 6.9 | SBS...PAB | 11.3 | 1x |
|  | 461-710 | | KE SL | 9.3 | AL.M... | 10.7 | AL.M... | 10.7 | | | |
| | 711-960 | | KE SL AL.M... | 9.3 10.7 | AL.M... | 10.7 | MK.250-1 | 9.1 | SBA.K... | 11.1 | 1x |
| | 961-1210 | | KE SL AL.M... | 9.3 10.7 | AL.M... | 10.7 | MK.500-1 | 9.1 | SBA.K... | 11.1 | 1x |
| | 1211-1250 | | KE SL AL.M... | 9.3 10.7 | AL.M... | 10.7 | MK.750-1 | 9.1 | SBA.K... | 11.1 | 1x |
|  | 461-1250 | 611-2300 | E1.A | 4.7 | | | | | SBS...PAB | 11.3 | 1x |

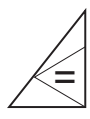
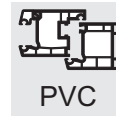

Turn fitting system - central handle position

Basic equipment for triangle windows - bottom handle position
 activPilot Comfort PADS

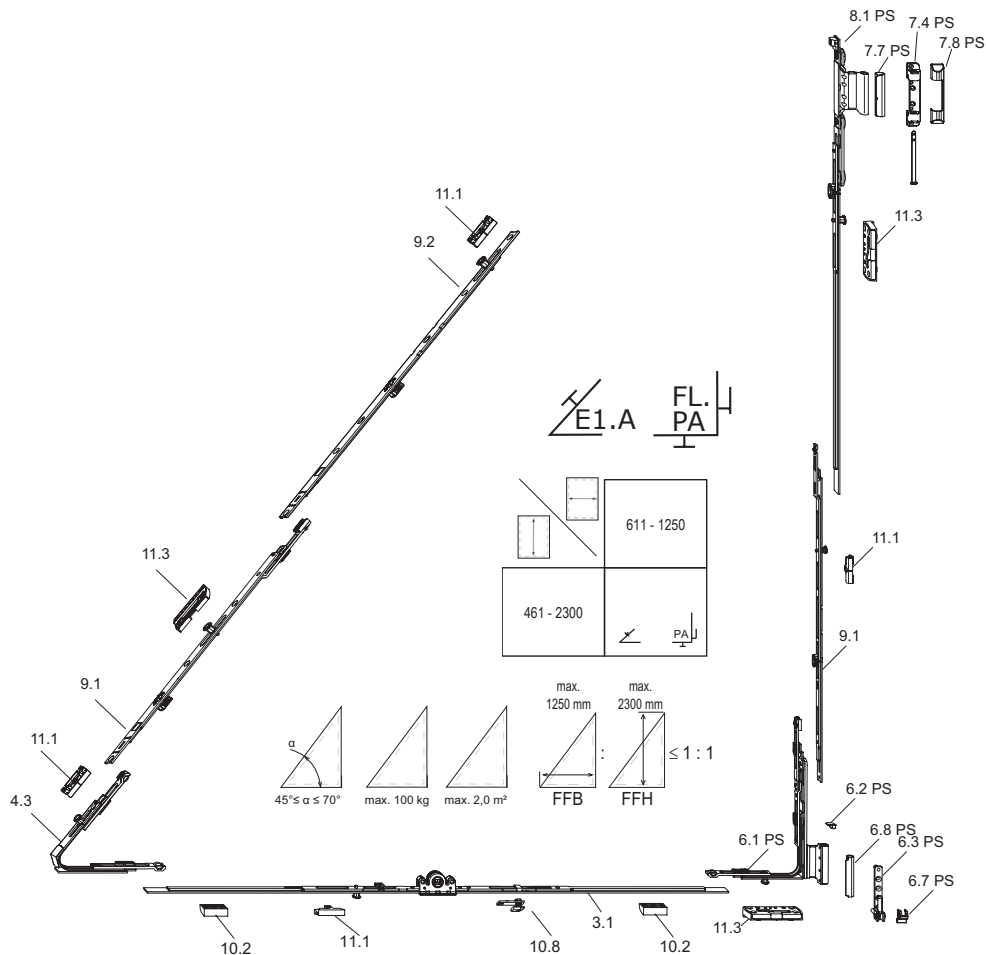

2



| |  |  | | Pos. |
|---|---|---|-------------|------|
|  | 461-1250 | 611-2300 | K.EL.CS... | 6.7 |
| | | | K.FL.C-W... | 6.8 |
| | | | K.SK... | 7.7 |
| | | | SLK SWR... | 7.8 |

You will find the components marked PS on the following pages. All other parts can be found in the activPilot Comfort PADK section.







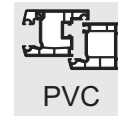
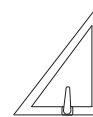

The shown distance between locking points is 800 mm.

The locking distances must be agreed with the system provider.

Turn fitting system - central handle position

Basic equipment for triangle windows - bottom handle position



| |  |  | | Pos. | | Pos. | | Pos. | | Pos. | |
|---|---|---|--------------|------|----------|-----------|-------------------------|--------------|-------------------------|--------------|----------|
|  | 611-710 | 611-2300 | GAM.800 | 3.1 | FSF | 10.16 | | | | | |
| | 711-870 | | GAM.1050-1 | 3.1 | FSF | 10.16 | | | SBA.K... | 11.1 | 1x |
| | 871-1250 | | GAM.1400-1 | 3.1 | FSF | 10.16 | | | SBA.K... | 11.1 | 1x |
|  | 461-1250 | 611-2300 | E1.A | 4.7 | | | | | SBS...PAB.. | 11.3 | 1x |
|  | 461-1250 | 461-554 | M.250-1 | 9.2 | | | | | SBS.PAB... | 11.3 | 1x |
| | | 555-805 | M.500-1 | 9.2 | | | | | SBS.PAB... | 11.3 | 1x |
| | | 806-1055 | M.750-1 | 9.2 | | | | | SBS.PAB... | 11.3 | 1x |
| | | 1056-1305 | MK.500-1 | 9.1 | M.500-1 | 9.2 | | | SBA.K...SBS. PAB... | 11.1 11.3 | 1x 1x |
| | | 1306-1555 | MK.500-1 | 9.1 | M.750-1 | 9.2 | | | SBA.K...SBS. PAB... | 11.1 11.3 | 1x 1x |
| | | 1556-1805 | MK.750-1 | 9.1 | M.750-1 | 9.2 | | | SBA.K... SBS. PAB... | 11.1 11.3 | 1x 1x |
| | | 1806-2055 | MK.750-1 | 9.1 | MK.500-1 | 9.2 | M.500-1 | 9.2 | SBA.K... SBS. PAB... | 11.1 11.3 | 2x 1x |
| 2056-2300 | MK.750-1 | 9.1 | MK.750-1 | 9.2 | M.500-1 | 9.2 | SBA.K... SBS. PAB... | 11.1 11.3 | 2x 1x | | |
|  | 461-1250 | 611-2300 | DL.K.PADS... | 8.1 | SL SWR | 7.4 PS | | | SBS...PAB.. | 11.3 | 1x |
|  | 461-1250 | 861-1250 | MK.250-1 | 9.1 | | | | | SBA.K... | 11.1 | 1x |
| | | 1111-1360 | MK.500-1 | 9.1 | | | | | SBA.K... | 11.1 | 1x |
| | | 1361-1610 | MK.750-1 | 9.1 | | | | | SBA.K... | 11.1 | 1x |
| | | 1611-1800 | MK.500-1 | 9.1 | MK.500-1 | 9.1 | | | SBA.K... | 11.1 | 2x |
| | | 1801-2110 | MK.500-1 | 9.1 | MK.750-1 | 9.1 | | | SBA.K... | 11.1 | 2x |
| 2111-2300 | MK.750-1 | 9.1 | MK.750-1 | 9.1 | | | SBA.K... | 11.1 | 2x | | |
|  | 461-1250 | 611-2300 | FL.C.PADS... | 6.1 | EL.CS... | 6.3 | S.FL.C-W... | 6.9 | SBS...PAB | 11.3 | 1x |

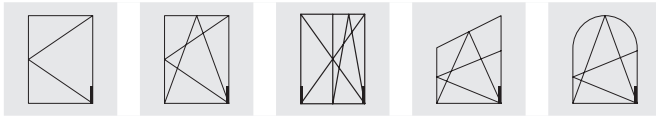
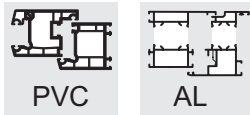

Corner hinges EL.CS

6

- Used in combination with overlap sash hinges FL.C or rebate sash hinges FL.C-W / FL.C.PA
- Large support area underneath the tilt axis
- For drilling instructions see group 15, installation drawings
- For sash weight see overview of articles
- Side adjustment ± 2 mm

Corner hinge cover K.EL.CS

- See separate product page

EL.CS

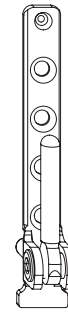

K.EL.CS



| Item designation | Item no. |  | Max. sash weight (kg) | VPA1 Pcs/type | VPA2 Pcs/type |
|------------------|----------|---|-----------------------|------------------|------------------|
| EL.CS.3-3-3 | 5064222 | 4 | 80 | 300 KK | 2400 EK |
| EL.CS.3-3-3.BR | 5064225 | 4 | 80 | 300 KK | 2400 EK |
| EL.CS.3-3-3.F9 | 5064224 | 4 | 80 | 300 KK | 2400 EK |
| EL.CS.3-3-3.WS | 5064223 | 4 | 80 | 300 KK | 2400 EK |
| EL.CS.6-3-3 | 5064226 | 4 | 100 | 300 KK | 2400 EK |
| EL.CS.6-3-3.BR | 5064229 | 4 | 100 | 300 KK | 2400 EK |
| EL.CS.6-3-3.F9 | 5064228 | 4 | 100 | 300 KK | 2400 EK |
| EL.CS.6-3-3.WS | 5064227 | 4 | 100 | 300 KK | 2400 EK |
| EL.CS.6-3-10 | 5064230 | 4 | 100 | 300 KK | 2400 EK |
| EL.CS.6-3-10.BR | 5064233 | 4 | 100 | 300 KK | 2400 EK |
| EL.CS.6-3-10.F9 | 5064232 | 4 | 100 | 300 KK | 2400 EK |
| EL.CS.6-3-10.WS | 5064231 | 4 | 100 | 300 KK | 2400 EK |
| EL.CS.6-3-22 | 5064234 | 4 | 130/150 | 300 KK | 2400 EK |
| EL.CS.6-3-22.BR | 5064237 | 4 | 130/150 | 300 KK | 2400 EK |
| EL.CS.6-3-22.F9 | 5064236 | 4 | 130/150 | 300 KK | 2400 EK |
| EL.CS.6-3-22.WS | 5064235 | 4 | 130/150 | 300 KK | 2400 EK |
| EL.CS.6-10-10.WS | 5064238 | 4 | 100 | 300 KK | 2400 EK |
| EL.CS.6-22-3 | 5064239 | 4 | 130/150 | 300 KK | 2400 EK |
| EL.CS.6-22-3.BR | 5064241 | 4 | 130/150 | 300 KK | 2400 EK |
| EL.CS.6-22-3.WS | 5064240 | 4 | 130/150 | 300 KK | 2400 EK |

WS = white; BR = brown, F9 = titanium coloured

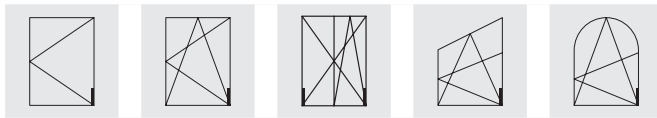
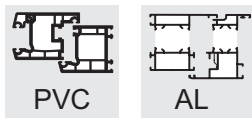

Corner hinges EL.CS-W

- Used in combination with rebate sash hinges FL.C-W / FL.C.PA
- Large support area underneath the tilt axis
- For drilling instructions see group 15, installation drawings
- Sash weight see Table of articles
- Side adjustment ± 2 mm
- With bolt support (max. parallel position of the bolt towards the corner hinge plate) avoids unintentional contact of the sash hinge roll and the corner hinge plate

- Recommendation for use: unfavourable sash formats, e. g.
- FFB > 1000 mm
- Sash rebate width: FFH > 1:1

Corner hinge cover K.EL.CS

- See separate product page

EL.CS-W

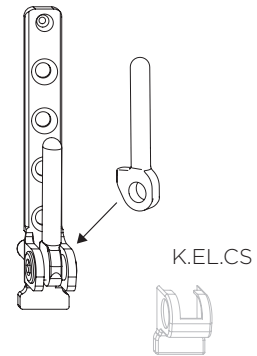

| Item designation | Item no. |  | Max. sash weight (kg) | VPA1 Pcs/type | VPA2 Pcs/type |
|--------------------|----------|---|-----------------------|------------------|------------------|
| EL.CS-W.6-3-3 | 5064244 | 4 | 100 | 300 KK | 2400 EK |
| EL.CS-W.6-3-3.F9 | 5064246 | 4 | 100 | 300 KK | 2400 EK |
| EL.CS-W.6-3-3.WS | 5064245 | 4 | 100 | 300 KK | 2400 EK |
| EL.CS-W.6-3-10 | 5064247 | 4 | 100 | 300 KK | 2400 EK |
| EL.CS-W.6-3-10.F9 | 5064249 | 4 | 100 | 300 KK | 2400 EK |
| EL.CS-W.6-3-10.WS | 5064248 | 4 | 100 | 300 KK | 2400 EK |
| EL.CS-W.6-3-22 | 5064250 | 4 | 130/150 | 300 KK | 2400 EK |
| EL.CS-W.6-3-22.F9 | 5064252 | 4 | 130/150 | 300 KK | 2400 EK |
| EL.CS-W.6-3-22.WS | 5064251 | 4 | 130/150 | 300 KK | 2400 EK |
| EL.CS-W.6-10-10.WS | 5064253 | 4 | 100 | 300 KK | 2400 EK |
| EL.CS-W.6-22-3 | 5064254 | 4 | 130/150 | 300 KK | 2400 EK |
| EL.CS-W.6-22-3.WS | 5064255 | 4 | 130/150 | 300 KK | 2400 EK |

WS = white; BR = brown, F9 = titanium coloured

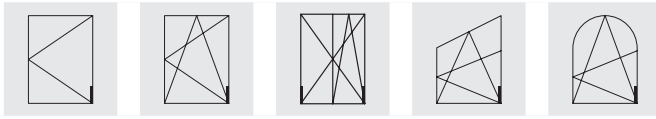
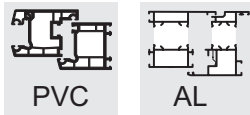

Corner hinge cap K.EL.CS

6

- Cover for narrow corner hinges EL.CS...
- For visual cover of the bottom area of the corner hinge
- Can be used left and right hand
- Available in different colours

EL.CS



K.EL.CS



| Item designation | Item no. | VPA1 Pcs/type | VPA2 Pcs/type | VPA3 Pcs/type |
|------------------|----------|------------------|------------------|------------------|
| K.EL.CS.BR | 5065117 | 100 BL | 1000 KK | 8000 EK |
| K.EL.CS.BZ-CN | 5065504 | 100 BL | 1000 KK | 8000 EK |
| K.EL.CS.BZ-RB | 5065508 | 100 BL | 1000 KK | 8000 EK |
| K.EL.CS.CW | 5065509 | 100 BL | 1000 KK | 8000 EK |
| K.EL.CS.F1 | 5065521 | 100 BL | 1000 KK | 8000 EK |
| K.EL.CS.F1-ELOX | 5065522 | 100 BL | 1000 KK | 8000 EK |
| K.EL.CS.F3 | 5065524 | 100 BL | 1000 KK | 8000 EK |
| K.EL.CS.F3-MG | 5065525 | 100 BL | 1000 KK | 8000 EK |
| K.EL.CS.F9 | 5065527 | 100 BL | 1000 KK | 8000 EK |
| K.EL.CS.LBR | 5065529 | 100 BL | 1000 KK | 8000 EK |
| K.EL.CS.LGR | 5065536 | 100 BL | 1000 KK | 8000 EK |
| K.EL.CS.PW | 5065537 | 100 BL | 1000 KK | 8000 EK |
| K.EL.CS.SW | 5065538 | 100 BL | 1000 KK | 8000 EK |
| K.EL.CS.UN77078 | 5065539 | 100 BL | 1000 KK | 8000 EK |
| K.EL.CS.WS | 5065119 | 100 BL | 1000 KK | 8000 EK |

AGR = anthracite grey, BR = brown, BZ-AM = bronze - antique brass, BZ-RB = bronze - red brown, BZ-CU = bronze coppery, CW = cream white, EV1 = anodised silver, F1 = silver colour, F1-elox = sim. to F1 anodised silver, F3 = gold colour, F3-MG = gold mat, F9 = titanium-coloured, LBR = clay brown, PW = pearl white, SG = silver grey, SGB = grey, SGR = dust grey, SL = silver look (galvanised), SW = deep black, WS = white

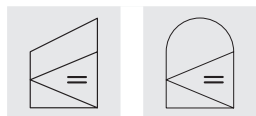
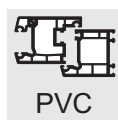

Sash hinges FL.C.PADS.20-13

- Parallel action possible via the control curve
- Operating sequence: locked position - turn position - parallel action
- Height adjustment ± 3 mm
- Central position is the factory default
- In combination with corner hinges EL.CS / EL.CS-W

Sash hinge cover K.FL.C-W

- Available in different colours

Sash hinge plug S.FL.C-W

- Can be used left and right hand
- Dirt protection for height adjustment device
- Available in different colours

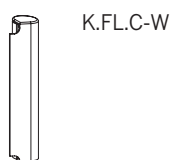
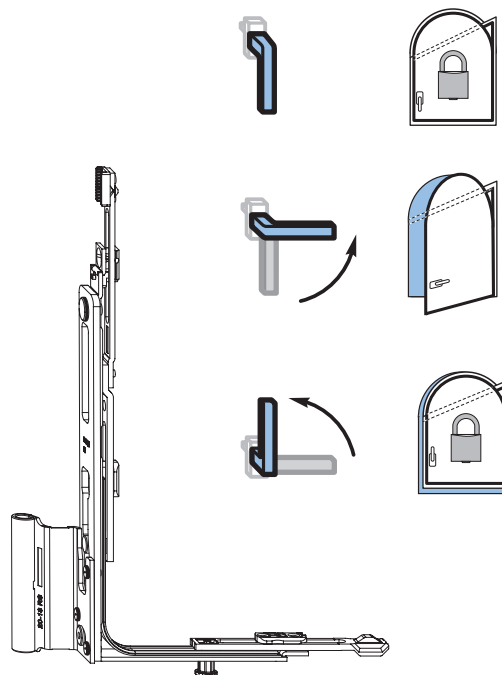

| Item designation | Item no. | | Max. sash weight (kg) | Overlap | Groove centre position | VPA1 Pcs/type | VPA2 Pcs/type | VPA3 Pcs/type |
|-----------------------|----------|---|-----------------------|---------|------------------------|---------------|---------------|---------------|
| FL.C.PADS.20-13.LS | 5069176 | 4 | 100 | 20 | 13 | 20 KK | 160 EK | |
| FL.C.PADS.20-13.RS | 5069175 | 4 | 100 | 20 | 13 | 20 KK | 160 EK | |
| FL.C.PADS.20-13.LS.F9 | 5069180 | 4 | 100 | 20 | 13 | 20 KK | 160 EK | |
| FL.C.PADS.20-13.RS.F9 | 5069179 | 4 | 100 | 20 | 13 | 20 KK | 160 EK | |
| FL.C.PADS.20-13.LS.WS | 5069178 | 4 | 100 | 20 | 13 | 20 KK | 160 EK | |
| FL.C.PADS.20-13.RS.WS | 5069177 | 4 | 100 | 20 | 13 | 20 KK | 160 EK | |
| K.FL.C-W.LS.BR | 5065127 | | | | | 100 BL | 300 KK | 2400 EK |
| K.FL.C-W.RS.BR | 5065126 | | | | | 100 BL | 300 KK | 2400 EK |
| K.FL.C-W.LS.BZ-AM | 5065575 | | | | | 100 BL | 300 KK | 2400 EK |
| K.FL.C-W.RS.BZ-AM | 5065574 | | | | | 100 BL | 300 KK | 2400 EK |
| K.FL.C-W.LS.BZ-RB | 5065577 | | | | | 100 BL | 300 KK | 2400 EK |
| K.FL.C-W.RS.BZ-RB | 5065576 | | | | | 100 BL | 300 KK | 2400 EK |
| K.FL.C-W.LS.CW | 5065579 | | | | | 100 BL | 300 KK | 2400 EK |
| K.FL.C-W.RS.CW | 5065578 | | | | | 100 BL | 300 KK | 2400 EK |
| K.FL.C-W.LS.F1 | 5065581 | | | | | 100 BL | 300 KK | 2400 EK |
| K.FL.C-W.RS.F1 | 5065580 | | | | | 100 BL | 300 KK | 2400 EK |
| K.FL.C-W.LS.F1-ELOX | 5065583 | | | | | 100 BL | 300 KK | 2400 EK |
| K.FL.C-W.RS.F1-ELOX | 5065582 | | | | | 100 BL | 300 KK | 2400 EK |
| K.FL.C-W.LS.F3 | 5065603 | | | | | 100 BL | 300 KK | 2400 EK |
| K.FL.C-W.RS.F3 | 5065602 | | | | | 100 BL | 300 KK | 2400 EK |
| K.FL.C-W.LS.F9 | 5065605 | | | | | 100 BL | 300 KK | 2400 EK |
| K.FL.C-W.RS.F9 | 5065604 | | | | | 100 BL | 300 KK | 2400 EK |
| K.FL.C-W.LS.SW | 5065607 | | | | | 100 BL | 300 KK | 2400 EK |
| K.FL.C-W.RS.SW | 5065606 | | | | | 100 BL | 300 KK | 2400 EK |
| K.FL.C-W.LS.WS | 5065129 | | | | | 100 BL | 300 KK | 2400 EK |
| K.FL.C-W.RS.WS | 5065128 | | | | | 100 BL | 300 KK | 2400 EK |
| S.FL.C-W.BR | 5065613 | | | | | 500 BL | 3000 KK | 24000 EK |
| S.FL.C-W.F1 | 5065614 | | | | | 500 BL | 3000 KK | 24000 EK |
| S.FL.C-W.F9 | 5065615 | | | | | 500 BL | 3000 KK | 24000 EK |
| S.FL.C-W.WS | 5065616 | | | | | 500 BL | 3000 KK | 24000 EK |

RS = right, LS = left

WS = white, BR = brown, EV1 = anodised silver, CW = cream white, F9 = titanium coloured, BZ-CU = bronze copper, BZ-RB (F4)= bronze red brown, RAL9007 = colour according to RAL

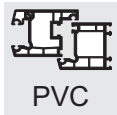

PVC

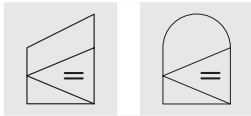

Turn hinge DL.K.PADS

- For radius head windows, studio and triangle windows
- Only one size of turn hinge
- Sash weight max. 100 kg
- Side adjustment ± 2 mm
- Used in combination with shear hinge SL SWR
- Parallel action possible via the control curve
- Operating sequence: locked position – turn position – parallel action

Shear hinge SL SWR

- For radius head windows, studio and triangle windows

Shear hinge cap SLK SWR

- Can be used left and right hand
- Available in different colours

Shear hinge cap SBK SW

- Can be used left and right hand
- Available in different colours

DL.K.PADS

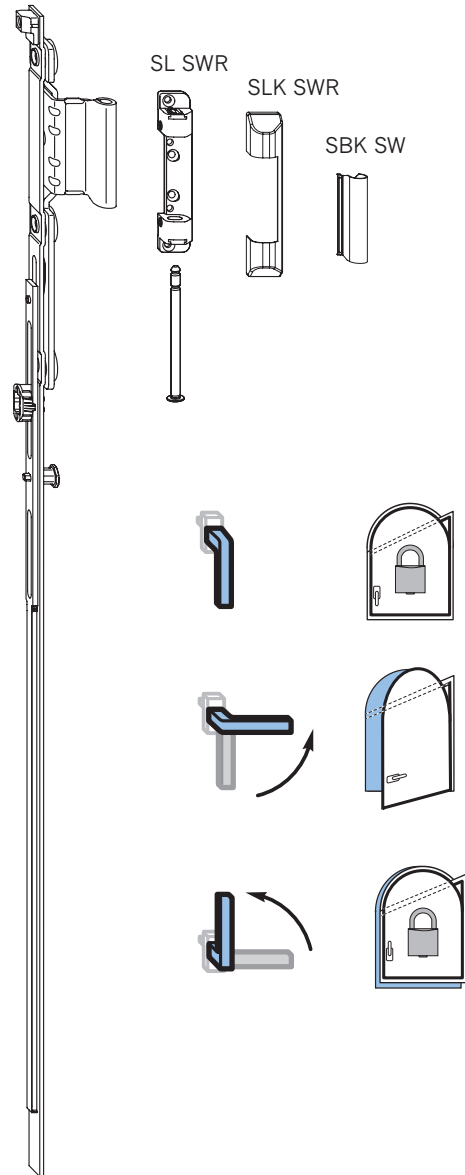

| Item designation | Item no. |  | Overlap | Groove centre position | Max. sash weight (kg) | VPA1 Pcs/type | VPA2 Pcs/type | VPA3 Pcs/type |
|-----------------------|----------|---|---------|------------------------|-----------------------|---------------|---------------|---------------|
| DL.K.PADS.20-13.LS | 5001586 | 6 | 20 | 13 | 100 | 10 BD | 200 EA | |
| DL.K.PADS.20-13.RS | 5001585 | 6 | 20 | 13 | 100 | 10 BD | 200 EA | |
| DL.K.PADS.20-13.LS.WS | 5001588 | 6 | 20 | 13 | 100 | 10 BD | 200 EA | |
| DL.K.PADS.20-13.RS.WS | 5001587 | 6 | 20 | 13 | 100 | 10 BD | 200 EA | |
| SL SWR SL | 1888216 | 6 | 20 | 13 | 100 | 1 BL | 200 KK | 1600 EK |
| SL SWR WS | 5004211 | 6 | 20 | 13 | 100 | 1 BL | 200 KK | 1600 EK |
| SL SWR F9 | 5004212 | 6 | 20 | 13 | 100 | 1 BL | 200 KK | 1600 EK |
| SLK SWR WS | 1539729 | 6 | 20 | 13 | 100 | 50 BL | 300 KK | 2400 EK |
| SLK SWR F9 | 1220106 | 6 | 20 | 13 | 100 | 50 BL | 300 KK | 2400 EK |
| SLK SWR F1 | 2201922 | 6 | 20 | 13 | 100 | 10 BL | 250 KK | 2000 EK |
| SLK SWR BR | 1539796 | 6 | 20 | 13 | 100 | 50 BL | 300 KK | 2400 EK |
| SBK SW WS | 1505705 | 6 | 20 | 13 | 100 | 100 BL | 500 KK | 12000 EK |
| SBK SW BR | 1505801 | 6 | 20 | 13 | 100 | 100 BL | 500 KK | 12000 EK |
| SBK SW F9 | 2364713 | 6 | 20 | 13 | 100 | 100 BL | 400 KK | 3200 EK |
| SBK SW F1 | 2201869 | 6 | 20 | 13 | 100 | 100 BL | 400 KK | 3200 EK |

RS = right, LS = left

WS = white, BR = brown, SL = silver, F1 = silver coloured, F3 = gold coloured, F9 = titanium coloured

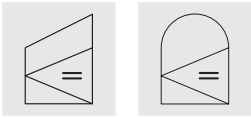
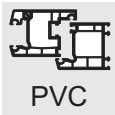

Frame parts

- Profile dependent see Group 11 (PADK), Frame Parts

Security Keep SBS....PAB

- Circumferential installation situation
- Available for mounting left and right hand
- Number of screws: 4
- The keep is marked "M" on the web for identification.
- Operating sequence: locked position – turn position – parallel action

Keep SBAK

- Can be used left and right hand

Spacer FT WSK

- Can be used left and right hand

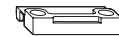
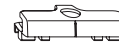
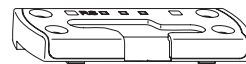

| | | | |
|-----------|--|-----------|-----------|
| 13 | Mounting instructions studio windows (AT) | 217 - 230 | 13 |
| 13.1 | Notes on these assembly instructions | | 13.1 |
| 13.2 | Shortening the fittings | | 13.2 |
| 13.4 | Mounting of studio fittings | | 13.3 |
| 13.6 | Function test / Operation | | 13.6 |
| 13 | Mounting instructions round arch windows (RB) | 231 - 244 | 13 |
| 13.1 | Notes on these assembly instructions | | 13.1 |
| 13.2 | Shortening the fittings | | 13.2 |
| 13.5 | Mounting of fittings for round-arch windows | | 13.5 |
| 13.6 | Function test / Operation | | 13.6 |

Notes on these assembly instructions

Prerequisites:

The mounting instructions are designed for mounting Winkhaus activPilot fittings for windows and glazed doors only. Fittings are designed for the following sash rebate sizes and sash weights:

- Min. sash rebate width 460 mm
- Max. sash rebate width 1250 mm
- Min. sash rebate height 610 mm
- Max. sash rebate height 2300 mm
- Max. sash size 2.0 m²
- Max. sash weight 100 kg
- 1 mm glass \approx 2.5 kg/m²
- Ratio between sash rebate width: Sash rebate height \leq 1 : 1
- Airgap 12 mm
- Overlap 20 mm
- Groove centre position 13 mm
- Frame rebate depth min. 29 mm
- Approved for centre gasket systems and rebate sealing systems with rain guard.



Note: From sash weights of 40 kg the filling must be bonded to the sash all around the window.



Note: In order to ascertain the permissible sash sizes and sash weights, please refer to the diagrams in the chapter "General Product Information".

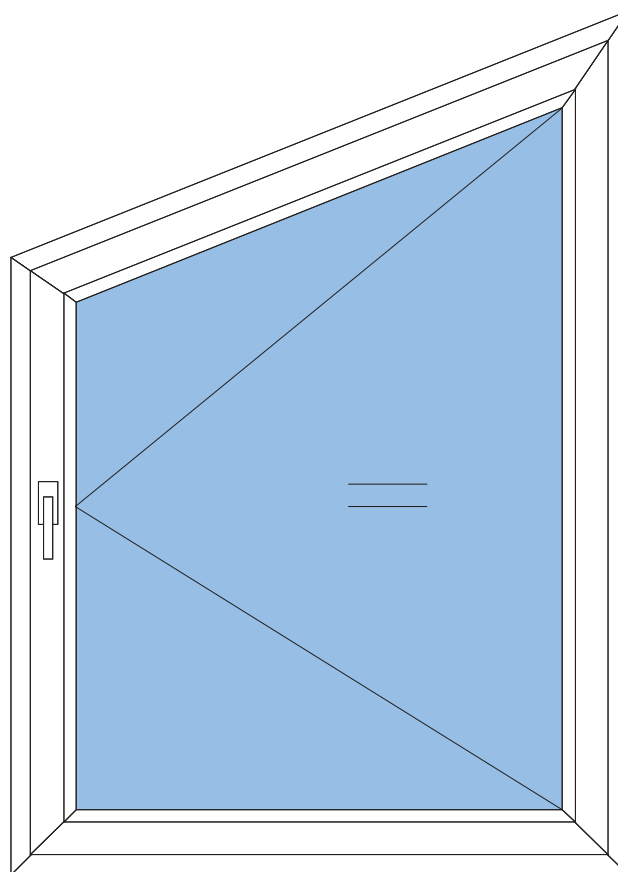

13.1

Persons involved in mounting fittings must have read and understood this fitting guide. Observe production liability information for all work with fittings. Manufacturer will accept no liability in cases of failure to comply with this guide, deployment of insufficiently qualified staff and unauthorised alterations.

The respective overall fitting must be selected from the original fitting components range. Winkhaus accepts no liability if non-original or unauthorised system accessory parts are used.



Please note! Winkhaus does not provide fastening screws for fitting. Always use fastening screws suitable for the window type and window dimensions.



Note: activPilot Comfort fittings are not suitable for use in panic doors! They are not recommended for passage doors.

Standard profile dimensions

See figure: Profile cross-section

The fitting can be used on PVC-U windows with a standard eurogroove.

i activPilot Comfort fittings are suitable for centre gasket systems or rebate sealing systems in combination with rain guards.

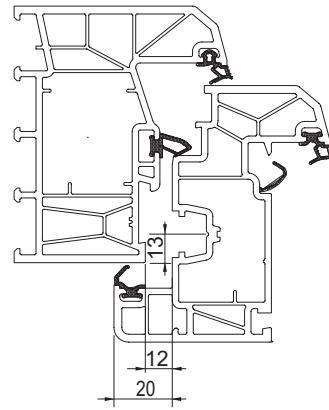

Profile cross-section

Studio variants

Studio components can be used for window elements with the following frame geometry:

Possible frame variants

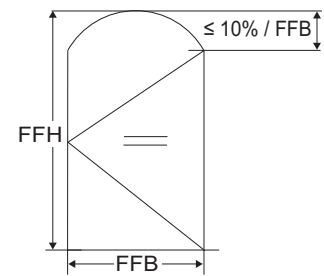
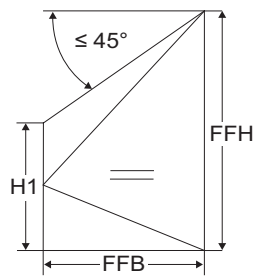
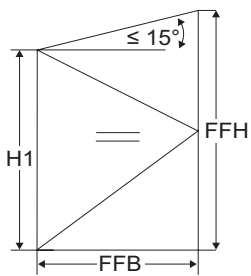

Shortening the fittings

A detailed description on shortening of fittings is available here. This description will be referred to in these assembly instructions.

See figure: Fittings prior to punching

- Always insert the face plate (1) and drive rod (2) perpendicularly from the top with the face plate (1) pointing to the pressure cylinder.

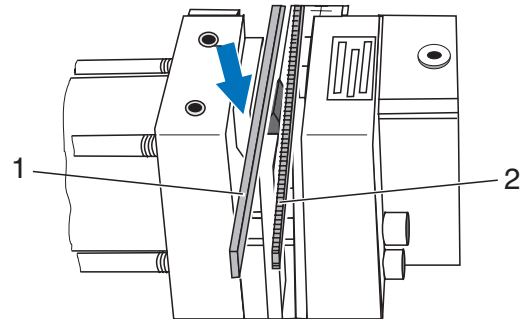

Fittings prior to punching

See figure: Fittings after punching

- After punching, always remove the face plate (1) and drive rod (2) perpendicularly in an upwards direction.

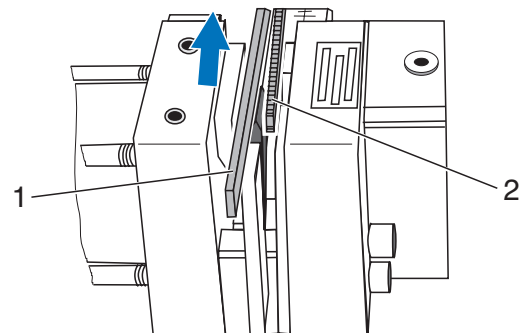

Fittings after punching

See figure: Cleaning the supporting surfaces

- Keep the supporting surfaces (3 and 4) clean.

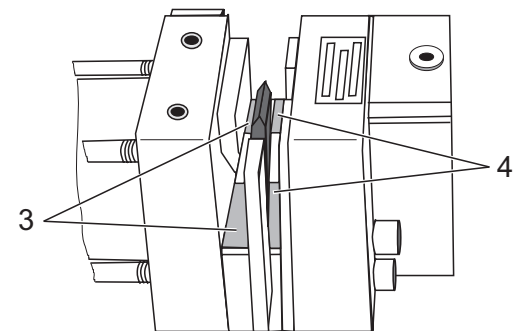

Cleaning the supporting surfaces

Shorten the drive rod GAM (central handle position)

See figure: Marking GAM

- Set measuring value FFH on the measuring device to the GAM mark.



Please note! If the GAM scale is displaced by one submarking, this corresponds to a longitudinal shift of 2 mm.

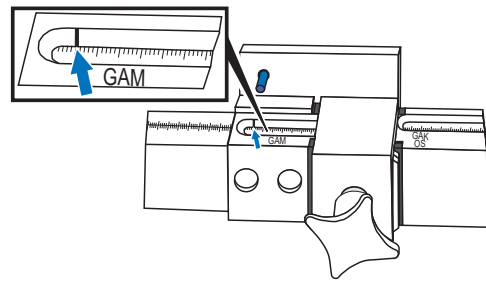

Marking GAM

See figure: Marking GAM

- Adjust the measured value FFH to the GAM mark on the measuring device.



Please note! If the GAM scale is displaced by one submarking, this corresponds to a longitudinal shift of 2 mm.

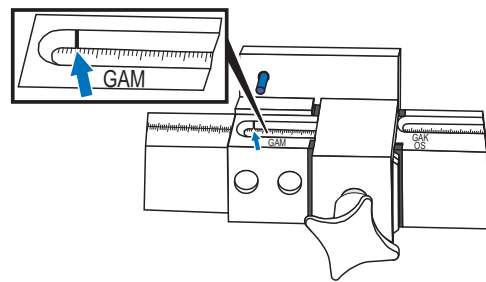

Marking GAM

See figure: Position for shortening drive rod

- Position the GAM drive rod at the scale; slot drill hole (2) onto bolt (1).
- Turn the GAM drive rod around, and slot the drill hole (3) onto the bolt (1), then trim the other side.
- Shorten the drive rod using the fitting punch.

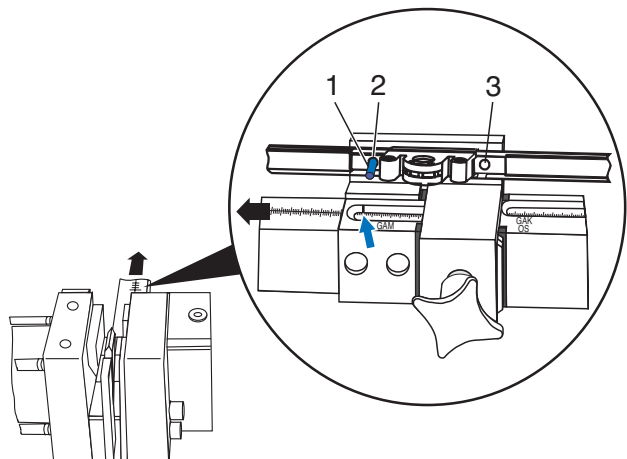

Position for shortening drive rod

Shorten the GAK / GASK drive rod (constant handle position) and top rod OS



Note: The double-sash drive rod must be trimmed before delivery.

See figure: Markings GAK and OS

- Set the measuring value FFH (GAK/GASK) or FFB (OS) on the measuring device to the GAK/OS mark.



Markings GAK and OS

See figure: Markings GAK and OS

- Adjust the measured value FFB (GAK) to the GAK/OS mark on the measuring device.

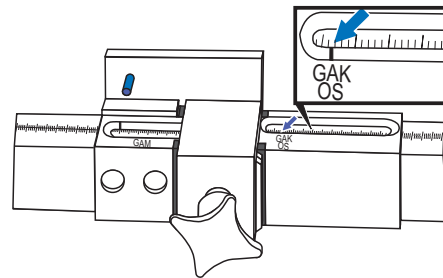

Markings GAK and OS

Mounting of fittings on sash

Parallel opening / turn studio window

Prepare the window for fitting. Then proceed as follows:

i Note: The following figures refer to a window for right hand use. When fitting a window for left-hand use, the figures will be mirror-inverted.

The following also applies:

- When viewing the window from the inside, the symbol is depicted as a full line.
- When viewing the window from the outside, the symbol is depicted as a dotted line.

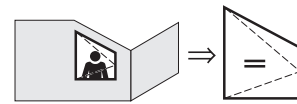
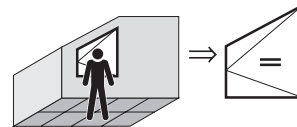

Determine the handle height:

Handle height for drive rod GAM

See figure: Sash rebate height FFH with central handle height GM

If you use a GAM drive rod ... (central handle position), the dimension GM is half the sash rebate height FFH.

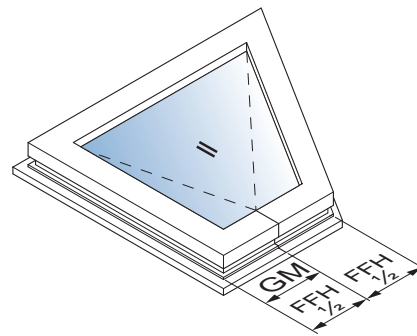

Sash rebate height FFH with central handle height GM

Handle height for drive rod GAK

If you use a GAK drive rod ... (constant handle position), dimension GK changes to reflect the sash rebate height FFH. The exact dimensions are specified in the following table.

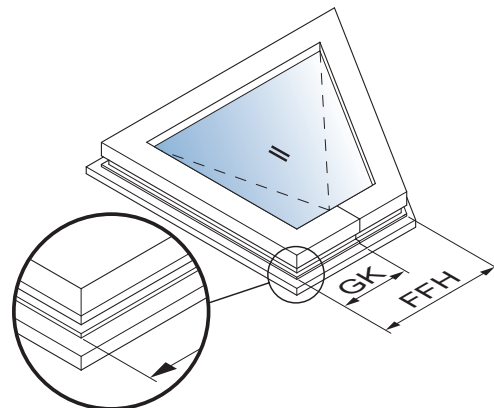

Sash rebate height FFH with constant handle position GK

See figure: Synoptical table: sash rebate height (FFH) / handle position (GK)

The table on the right gives a survey on the handle height (GK) of GAK with regard to the sash rebate height (FFH).

| FFH | |
|-------------|------------|
| 230 – 324 | GK = 114 * |
| 325 – 420 | GK = 114 * |
| 421 – 460 | GK = 210 |
| 461 – 700 | GK = 210 |
| 701 – 850 | GK = 260 |
| 851 – 1100 | GK = 375 |
| 1101 – 1325 | GK = 550 |
| 1326 – 1525 | GK = 550 |
| 1526 – 1775 | GK = 550 |
| 1776 – 2000 | GK = 1050 |
| 2001 – 2225 | GK = 1050 |

Synoptical table: sash rebate height (FFH) / handle position (GK)
* Requires the use of E3 corner drive

See figure: Scale drawing “Gear lock”

- Mill the gear housing from the rebate side.
- Drill holes for gear case (ø 12 mm) as per scale drawing.

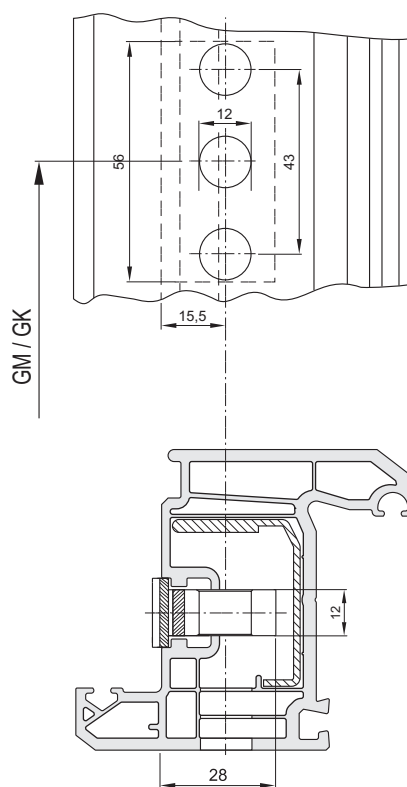

Scale drawing “Gear lock”

See figure: Corner drives E1 (1), E1.A (2)

- Mounting of interlocking rods:
 - Prior to insertion, bend the corner drive E1.A to rectangular shape.
 - Fit the corner drive (2) into the fitting groove at the top of the sash so that the octagonal bolt is on the top side.
 - Fit the corner drive (1) into the fitting groove at the bottom of the sash so that the octagonal bolt is on the underside.
 - Fix both corner drives (1, 2) on the drive side with a single screw each.

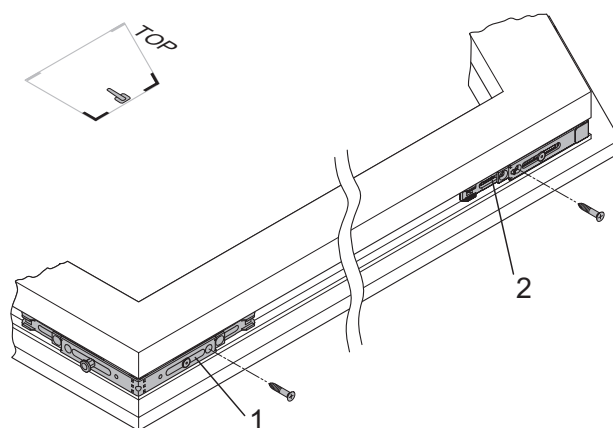

Corner drives E1 (1), E1.A (2)

See figure: Drive rod GAM/GAK

- Mount the drive rod:
 - Press the drive rod into the eurogroove.
 - Fit the handle to position the drive rod.
 - Mark the length of the drive rod on the flush edges of the corner drives.
 - Remove the handle and take the drive rod out of the fitting groove.
 - Mark and trim the drive rod using a punching press.
 - Mount the drive rod:
 - Abut the drive rod (3) flush against the corner drive (1).
 - Allow the teeth on the drive rod to click into position on the gear rack on the corner drive.
 - Clip the drive rod into the corner drive (4) in the same way.
 - Screw the drive rod from the bottom up.

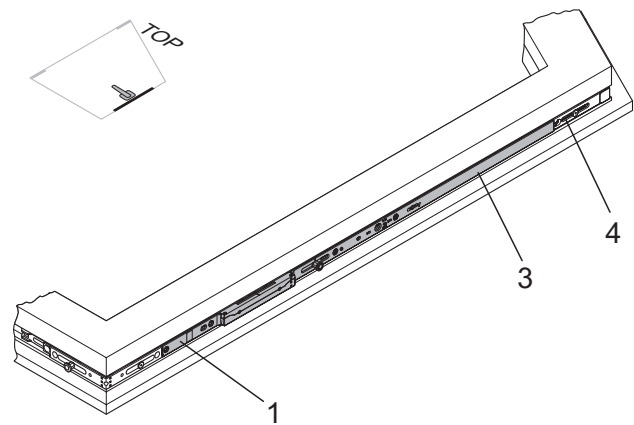

Drive rod GAM/GAK

See figure: Fail safe device FSF

- Mount the fail safe device:
 - Insert the fail safe device on the hole pattern of the drive rod and fix with a screw.
 - If required, turn the head by 90° (depends on profile).
 - Mounting a frame part is not necessary.

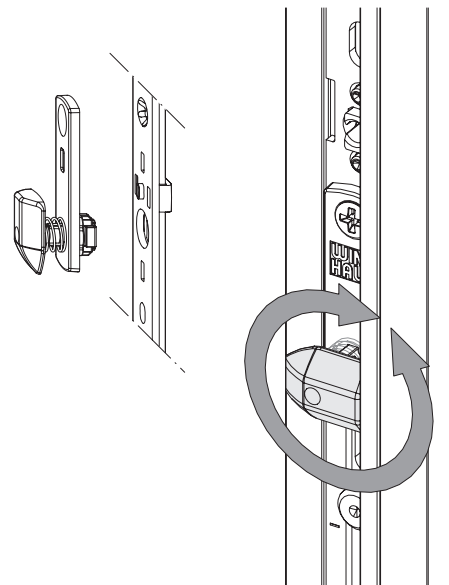

Fail safe device FSF

Important to know:

- The component's delivery state is neutral with regard to the DIN direction!
- After installation the tip of the pressure piece must be directed towards the frame!
- For airgaps smaller or larger than 12 mm an adjustment is possible by turning the plastic part to the left or to the right!

See figure: Sash hinge FLC.PADS

- Fitting the sash hinge:
 - Fit the sash hinge into the eurogroove at the bottom of the sash so that the octagonal bolt is on the underside.
 - Fix the sash hinge on the hinge side with 2 screws and on the underside using 1 screw.
 - Measure the sash rebate width (FFB).



Note: Fit the sash hinge in place with \varnothing 3.9 to 4.2 mm screws. Min. screw length 25 mm. Make sure that the sash hinge is entirely flush within the eurogroove.

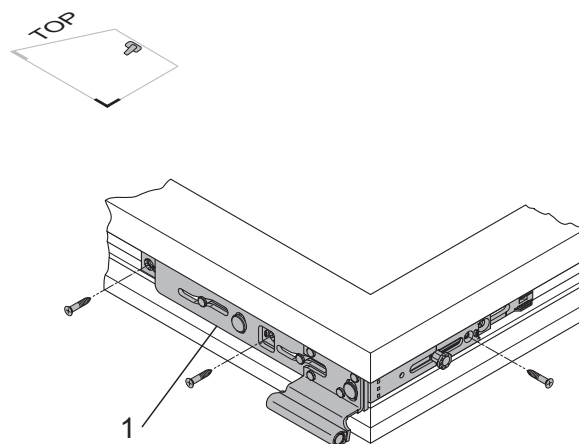

Sash hinge FLC.PADS

See figure: Interlocking rod MK (horizontal)

- Fit the interlocking rod at the bottom:
 - Abut the interlocking rod (2) flush against the corner drive (1).
 - Click the interlocking rod gears into the teeth of the corner drive.
 - Press the interlocking rod into the fitting groove.
 - Screw the interlocking rod in place.
 - Tighten the screw (3) fully to release the central fastening.

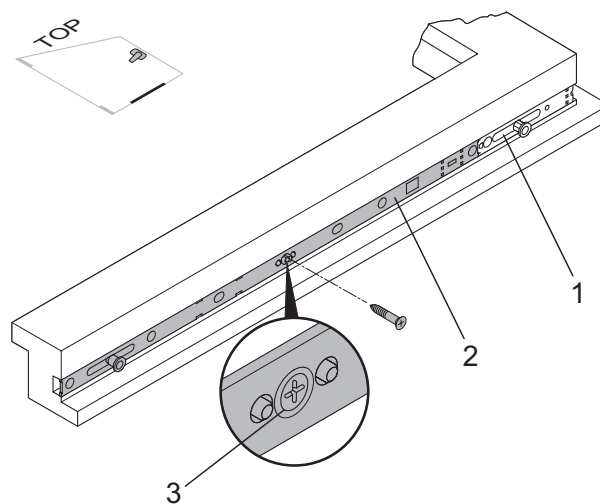

Interlocking rod MK (horizontal)

See figure: Coupling element KE (horizontal)

- Mount coupling element on the underside:
 - Abut the coupling element (2) flush against the corner drive (1) and slot into eurogroove.
 - Mark the length of the coupling element at the joint edge of the interlocking rod (3).
 - Remove the coupling element from the eurogroove.
 - Mark and trim the coupling element using a punching press.
 - Abut the coupling element (2) flush against the corner drive (1).
 - Click the coupling element into the teeth in the corner drive.
 - Slot the coupling element into the gearing of the interlocking rod (3) in the same way.
 - Press the coupling element into the eurogroove.
 - Screw the coupling element in place.

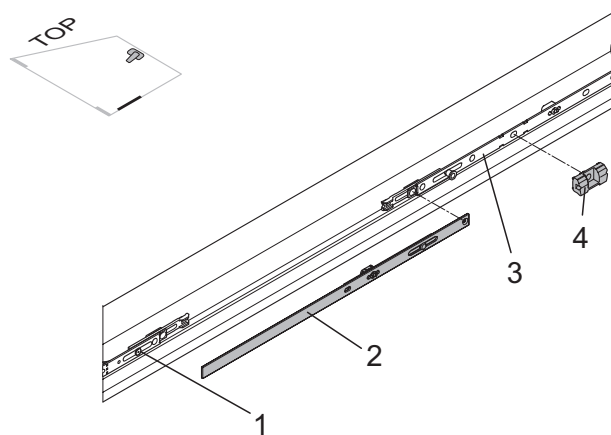

Coupling element KE (horizontal)

13.3

See figure: Interlocking rod M/MK (hinge side)

- Install Interlocking Rod on the hinge side.
 - Abut the interlocking rod (1) against the sash hinge (2).
 - Click the interlocking rod gears into the teeth of the corner drive.
 - Press the interlocking rod into the fitting groove.
 - Screw the interlocking rod from the bottom up.
 - Tighten the screw (3) fully to release the central fastening.

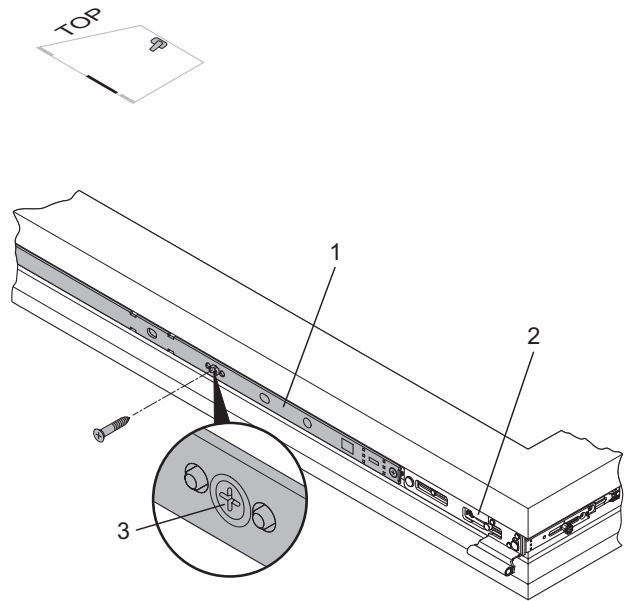

Interlocking rod M/MK (hinge side)



Please note! Damage to fittings. If the central fastening is not released, the locking device cannot be actuated. Use of force will lead to torsion of the fittings. Always insert the screw fully up to the stop.



Important to observe for Trocal 88+ profile system! For Trocal 88+ please remove the centre bar at the frame (bottom hinge side, at level of sash hinge). From frame rebate edge approx. 70 mm to the top!

See figure: Turn hinge DL.PADS

- Fit the turn hinge
 - Mark frame rebate height 50 mm on the sash frame.
 - Position the turn hinge (2) with the cover plate upper edge being on the "FFH-50 mm" mark.
 - Mark the length of the turn hinge.
 - Remove the turn hinge from the fitting groove.
 - Mark and trim the turn hinge using a punching press.
 - Fit the turn hinge
 - Insert the turn hinge at the FFH-50 mm mark. Click the gears end into the teeth of the interlocking rod or sash hinge.
 - Screw the turn hinge from top down.
 - Important: Use only screws with a minimum length of 30 mm.

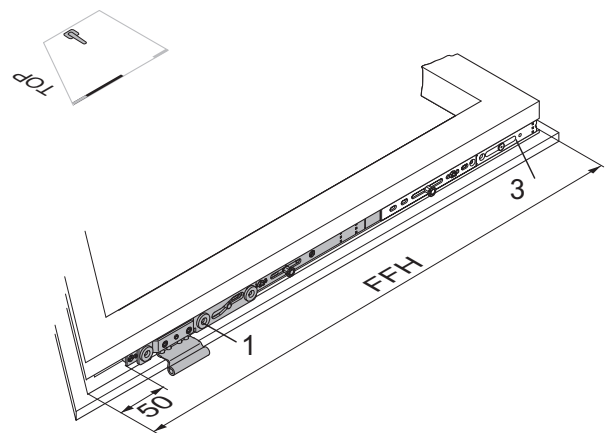

Turn hinge DL.PADS



Important: The upper edge of the cover plate must end at a min. sash rebate height FFH-50.



Note: the last locking point should be as close to the top as possible. You may need to fit multiple centre locks hinge side for this reason.

- Mount the interlocking rod M/MK on the diagonal.
 - Abut the interlocking rod against the corner drive E1.A.
 - Click the interlocking rod gears into the teeth of the corner drive.
 - Press the interlocking rod into the fitting groove.
 - Screw the interlocking rod from the bottom up.
 - Tighten the screw (3) fully to release the central fastening.

Mounting of fittings on the window frame

Parallel opening / turn studio window

See figure: Drilling jig LE.B.EL-SL.K corner hinge

- Mounting the corner hinge
 - Drill \varnothing 2.5 to 3 mm pilot holes for corner hinges and drill \varnothing 6 mm pilot holes for spindle plug positions.
 - Drill holes for corner hinge (4) in line with mounting jig (1).
 - Fit the corner hinge (4) and use screws to fasten in place in line with product instructions.



Please note! Damage to fittings. If the central fastening is not released, the locking device cannot be actuated. Use of force will lead to torsion of the fittings. Always insert the screw fully up to the stop.

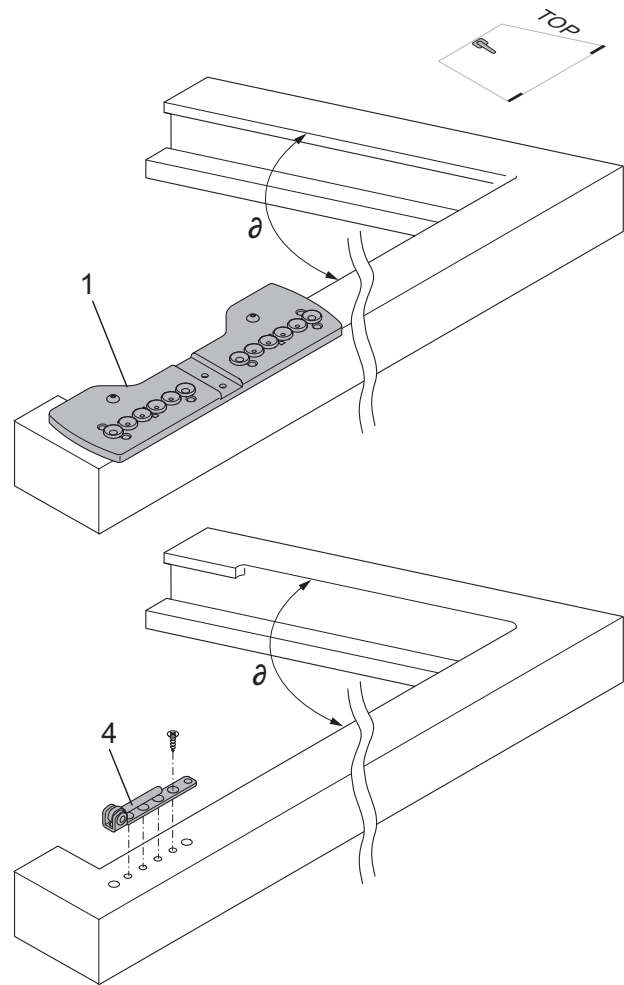

Mounting jig LE.B.EL-SL.K
Corner hinges

13.3

See figure: Shear hinge SWR ... for studio windows

- Mount the shear hinge.
 - Mount the shear hinge (3) on the shear band (2) using the pin (4).
 - Mount the sash.
 - Place the sash on the corner hinge (5).
 - Place the sash on the frame.
 - Press the sash and shear hinge as far out as possible (see arrow) against the frame edge.
 - Pre-drill the screw positions through the shear hinge drill holes (1) with \varnothing 2.5 to 3 mm drill.
 - Screw the shear hinge into place (screws in line with details in Product Liability Information).



Note: Do not fit shear hinges and corner hinges until after milling off the frame rebate edge and fitting the keeps. Holes for corner and shear hinges

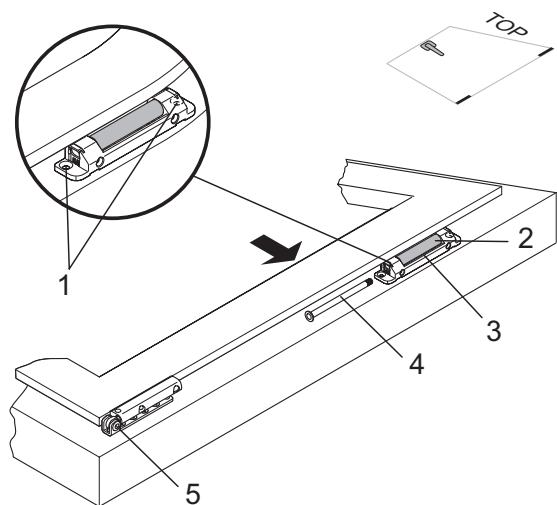

Shear hinge SWR ... for studio windows

Keep positions

The following figures show the keep position options. The number of keeps depends on the size of the window.



Note: The dimensions in the drawings are for frame rebate edge to striking plate profile edge. due to the top part of the frame not being right-angled for studio windows, it is impossible to use a mounting template to fit the keeps. This is why you need to mark the keep positions manually on the frame.

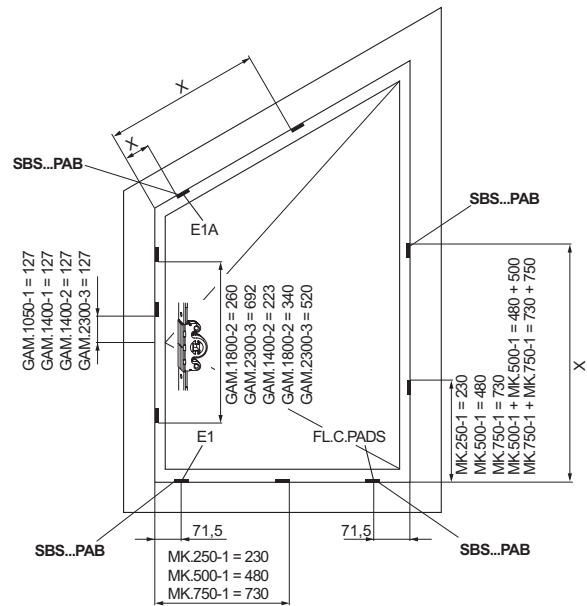

Keep positions "central handle position"
X = Dimension in elevation

See figure: Keep positions "constant handle position"

- Keep position X on slopes:
 - Mount the sash.
 - The handle is in horizontal position; the window is unlocked so that the mushroom heads are in a central position.
 - Abut the sash so that you can mark the outer edge of the mushroom bolt on the frame.
 - Position the keep:
 - The gap between the outer edge of the mushroom bolt and the profile edge of the keep is 3 to 4 mm.

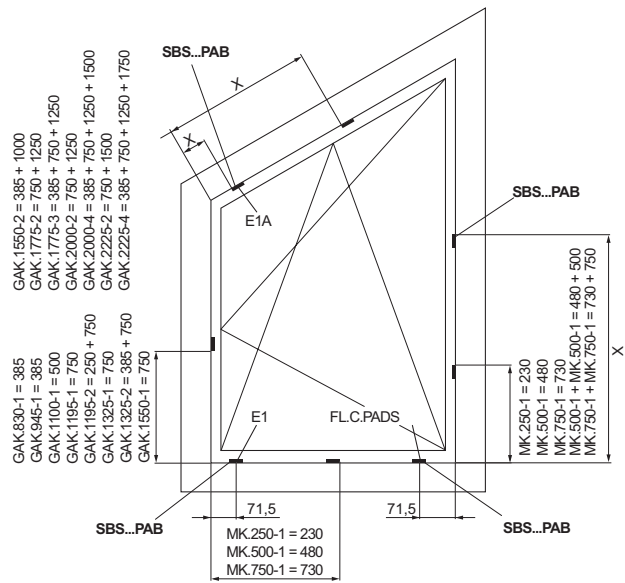

Keep positions "constant handle position"
X = Dimension in elevation



Note: When marking, note the run-in sides of the keeps.

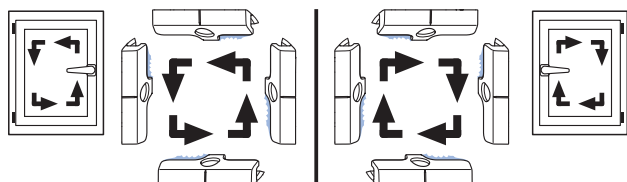

Run-in sides

Function test / Operation

Studio and radius-head windows with parallel / turn opening

Operating sequence: locked position – turn position – parallel action

Place the handle and operate once as follows to release the central fastening.

If the handle is moved to the crosswise position from below, the fitting is in the turn position. The sash is brought into the parallel position by turning further by 90° to the 180° position. To close the window, the handle must be turned downwards to the initial position.

i Note: The handle will be stiffer than normal the first time it is used. A clicking noise will be heard during actuation. Keep the window closed during actuation.

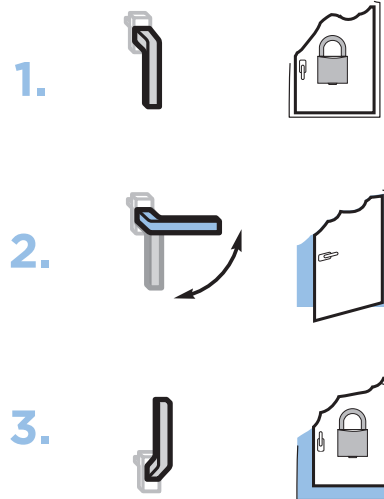
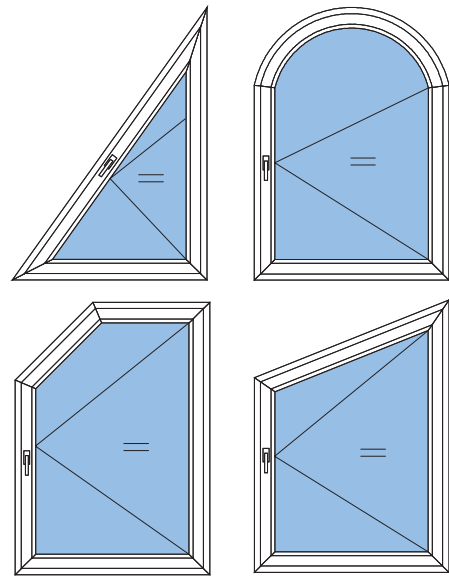

activPilot Comfort PADS – Turn and parallel opening of special window types

Technology and function description

See figure: Function SBS.K.PAB...PAS

- If the octagonal locking bolt is in position 1, the window is locked.
- If the octagonal locking bolt is in the centre (position 2), the window is in the turn position.
- If the octagonal locking bolt is in position 3, there is an opening gap of approx. 6 mm in the parallel position.

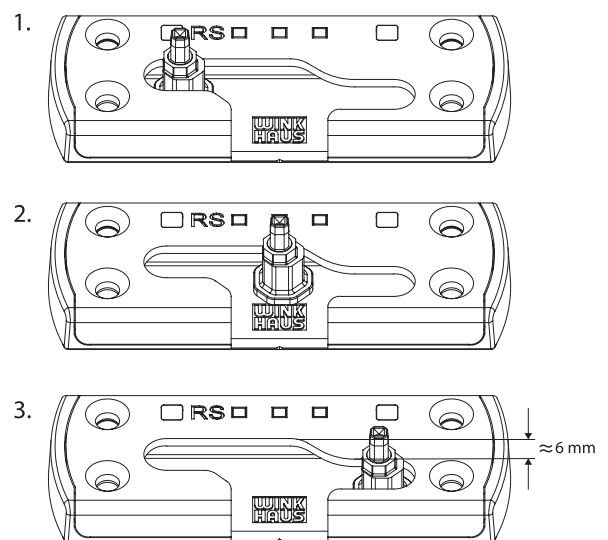

Function SBS.K.PAB...PAS

| | | |
|-----------|--|-----------|
| 13 | Mounting instructions round arch windows (RB) | 231 - 244 |
| 13.1 | Notes on these assembly instructions | |
| 13.2 | Shortening the fittings | |
| 13.5 | Mounting of fittings for round-arch windows | |
| 13.6 | Function test / Operation | |

13

13.1

13.2

13.5

13.6

Notes on these assembly instructions

Prerequisites:

The mounting instructions are designed for mounting Winkhaus activPilot fittings for windows and glazed doors only. Fittings are designed for the following sash rebate sizes and sash weights:

- Min. sash rebate width 460 mm
- Max. sash rebate width 1250 mm
- Min. sash rebate height 610 mm
- Max. sash rebate height 1800 mm
- Max. sash size 2.0 m²
- Max. sash weight 100 kg
- 1 mm glass \approx 2.5 kg/m²
- Ratio between sash rebate width: Sash rebate height \leq 1 : 1



Note: From sash weights of 40 kg the filling must be bonded to the sash all around the window.



Note: In order to ascertain the permissible sash sizes and sash weights, please refer to the diagrams in the chapter "General Product Information".

Persons involved in mounting fittings must have read and understood this fitting guide. Observe production liability information for all work with fittings. Manufacturer will accept no liability in cases of failure to comply with this guide, deployment of insufficiently qualified staff and unauthorised alterations.

The respective overall fitting must be selected from the original fitting components range. Winkhaus accepts no liability if non-original or unauthorised system accessory parts are used.



Please note! Winkhaus does not provide fastening screws for fitting. Always use fastening screws suitable for the window type and window dimensions.



Note: activPilot Comfort fittings are not suitable for use in panic doors! They are not recommended for passage doors.

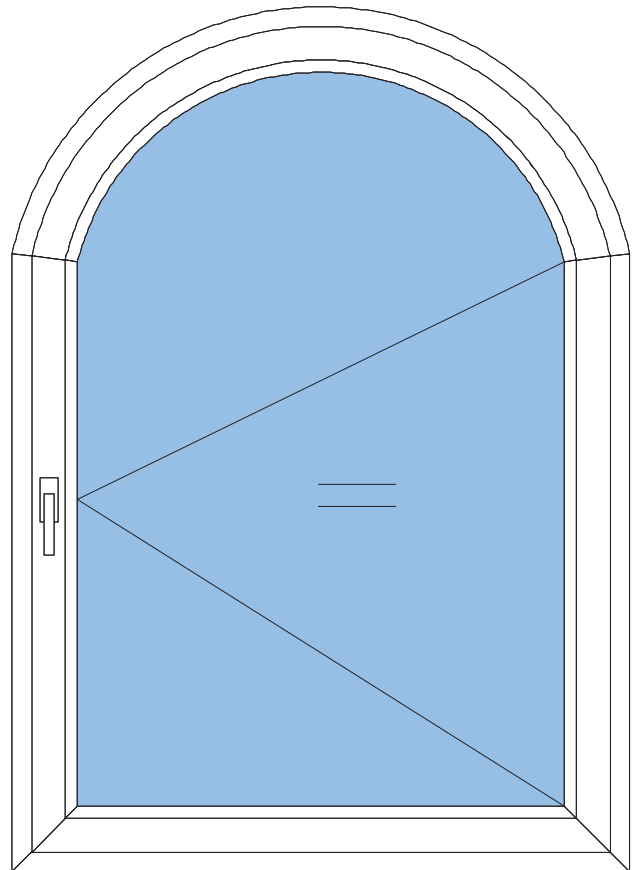

Standard profile dimensions

See figure: Profile cross-section

The fitting can be used on PVC-U windows with a standard eurogroove.



activPilot Comfort fittings are suitable for centre gasket systems or rebate sealing systems in combination with rain guards.

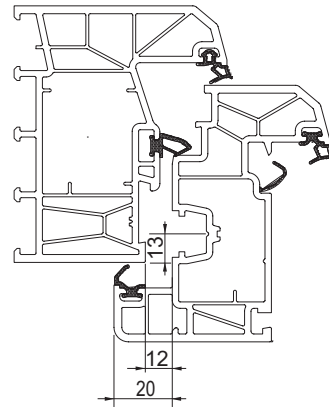

Profile cross-section

Shortening the fittings

See chapter Studio Windows

Mounting of fittings on sash

Parallel opening / turn radius-head window

Prepare the window for fitting. Then proceed as follows:



Note: The following figures refer to a window for right hand use. When fitting a window for left-hand use, the figures will be mirror-inverted.

The following also applies:

- When viewing the window from the inside, the symbol is depicted as a full line.
- When viewing the window from the outside, the symbol is depicted as a dotted line.

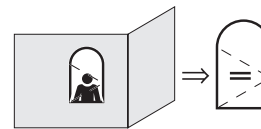
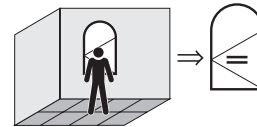

Determine the handle height:

Handle height for drive rod GAM

See figure: Sash rebate height FFH-R with central handle position GM

If you use a GAM drive rod (central handle position), dimension GM is half the sash rebate height FFH-R.

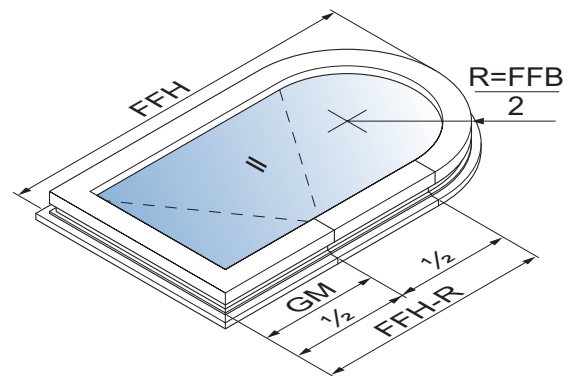

Sash rebate height FFH-R with central handle position GM

Handle height for drive rod GAK

See figure: Sash rebate height FFH-R with constant handle position GK: if you use a GAK ... drive rod ... (constant handle position), the GK dimension changes to reflect the sash rebate height FFH-R. The exact dimensions are specified in the following table.

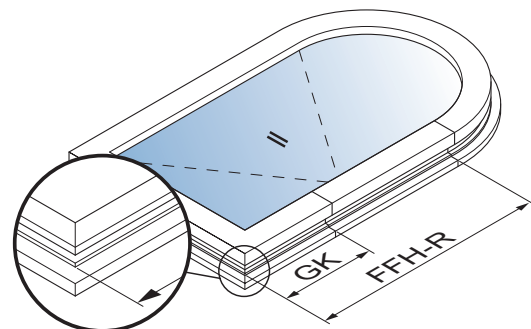

Sash rebate height FFH-R with constant handle height GK

13.5

See figure: Synoptical table sash rebate height (FFH-R) / handle position

The table on the right gives a survey on the handle height (GK) of GAK with regard to the sash rebate height (FFH).

| FFH | GK |
|-------------|------------|
| 230 – 324 | GK = 114 * |
| 325 – 420 | GK = 114 * |
| 421 – 460 | GK = 210 |
| 461 – 700 | GK = 210 |
| 701 – 850 | GK = 260 |
| 851 – 1100 | GK = 375 |
| 1101 – 1325 | GK = 550 |
| 1326 – 1525 | GK = 550 |
| 1526 – 1775 | GK = 550 |
| 1776 – 2000 | GK = 1050 |
| 2001 – 2225 | GK = 1050 |

Synoptical table sash rebate height (FFH-R) / handle position
 * Requires the use of E3 corner drive

See figure: Scale drawing "Gear lock"

- Drill holes for gear case (ø 12 mm) as per scale drawing.
- Mill the gear housing from the rebate side.

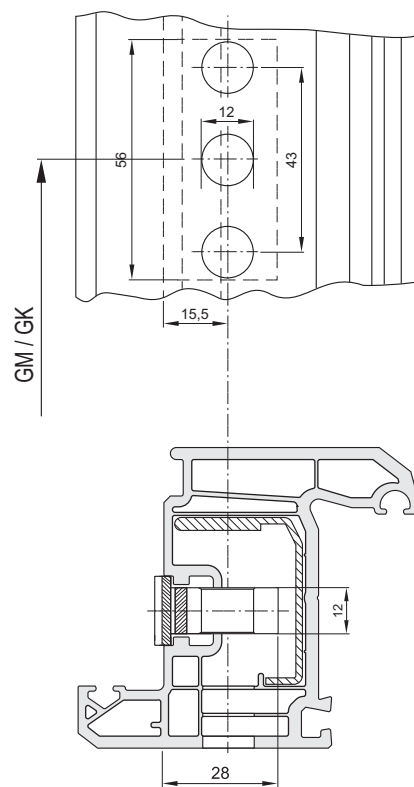

Scale drawing "Gear lock"

See figure: Sash hinges

- Fitting the sash hinge:
 - Fit the sash hinge into the eurogroove at the bottom of the sash so that the octagonal bolt is on the underside.
 - Fix the sash hinge on the hinge side with 2 screws and on the underside using 1 screw.
 - Measure the sash rebate width (FFB).

i Note: Fit the sash hinge in place with ø 3.9 to 4.2 mm screws. Min. screw length 25 mm. Make sure that the sash hinge is entirely flush within the eurogroove.

! Important to observe for Trocal 88+ profile system! For Trocal 88+ please remove the centre bar at the frame (bottom hinge side, at level of sash hinge). From frame rebate edge approx. 70 mm to the top!

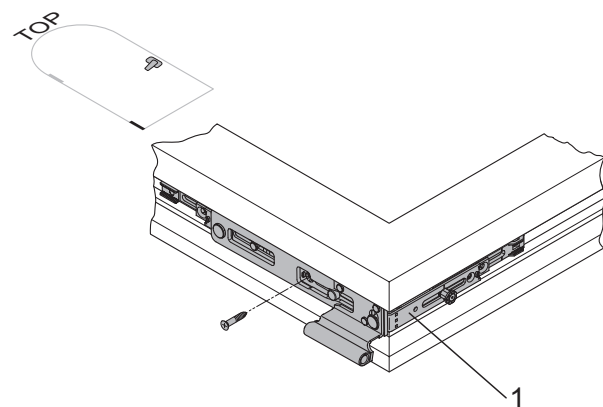

Sash hinges

See figure: Corner drive E1

- Fix the bottom corner drive into place.
- Fit the corner drive (1) into the fitting groove at the bottom of the sash so that the octagonal bolt is on the underside.
- Attach the corner drive (1) hinge side with a single screw.

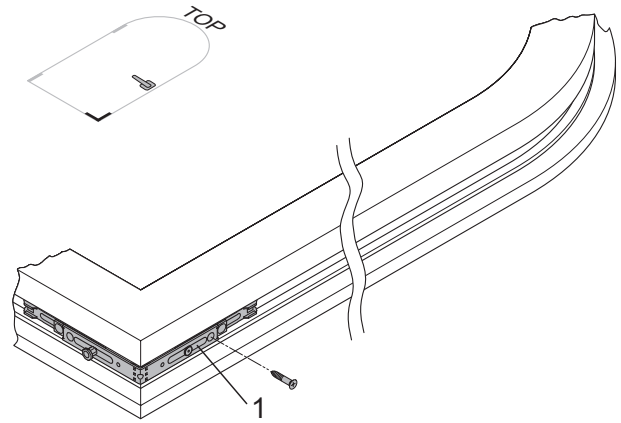

Corner drive E1



Note: If the sash rebate width is $FFB < 750$ mm, the connecting rail AARB (1) must be shortened behind the drill hole for the second locking bolt.

Only for sash rebate width $FFB < 750$ mm:

See figure: Connecting rail AARB for $FFB < 750$ mm

- Before shortening, push the locking bolt (4) into locking position (see arrow) to make sure the spring (2) is cut at the right position.
- Saw through the connecting rail (3) at the notch (1).

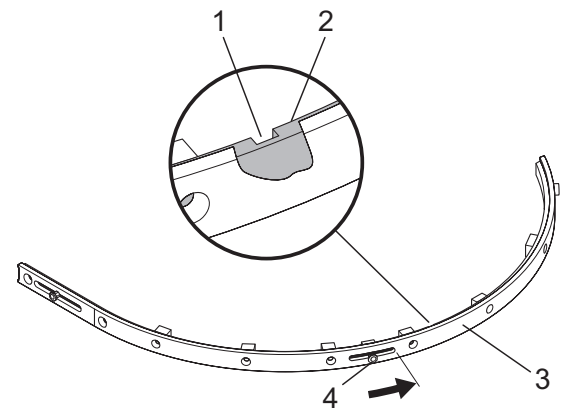

Connecting rail AARB for $FFB < 750$ mm

13.5

See figure: Connecting rail AARB

- Mounting of the connecting rail:
 - Make mark "FFH-R" on the sash.
 - Place the connecting rail (1) into the eurogroove, aligning the notch mark with the "FFH-R" mark.
 - Screw the connecting rail from the "FFH-R" mark in the direction of the bend.



Please note! Damage to connecting rod. You must not bend out the bottom corner drive (1) as it may otherwise buckle at drill hole positions. The connecting rod would not perfectly match the contour of the arch when screwed into place.

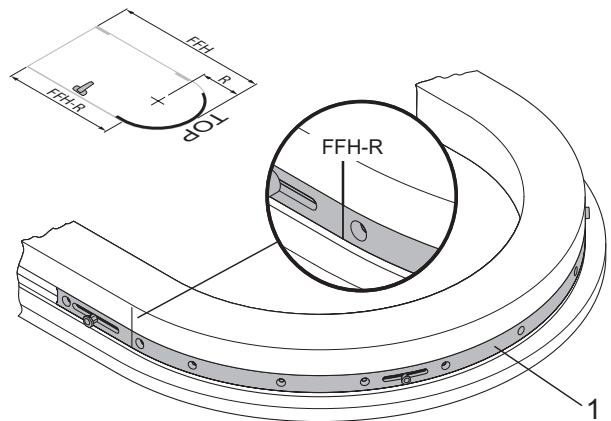

Connecting rail AARB

See figure: Drive rod GAM/GAK

- Mount the drive rod:
 - Press the drive rod into the eurogroove.
 - Fit the handle to position the drive rod.
 - Mark the length of the drive rod on the butt joint with the corner drive (1) and on the butt joint with the connecting rail (4).
 - Remove the handle and take the drive rod out of the fitting groove.
 - Mark and trim the drive rod using a punching press.
 - Mount the drive rod:
 - Abut the drive rod (2) flush against the corner drive (1).
 - Allow the teeth on the drive rod to click into position on the gear rack on the corner drive.
 - Clip the drive rod into the connecting rail (4) in the same way.
 - Screw the drive rod from the bottom up.

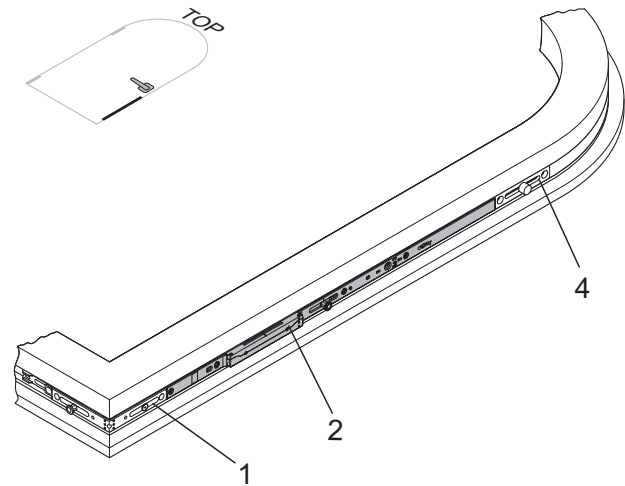

Drive rod GAM/GAK

See figure: Fail safe device FSF

- Mount the fail safe device:
 - Insert the fail safe device on the hole pattern of the drive rod and fix with a screw.
 - If required, turn the head by 90° (depends on profile).
 - Mounting a frame part is not necessary.

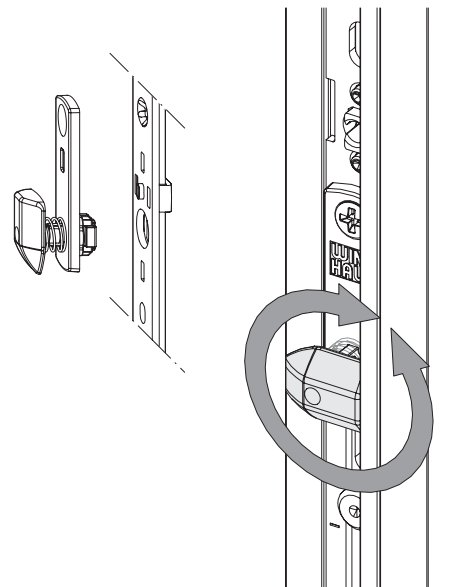

Fail safe device FSF

Important to know:

- The component's delivery state is neutral with regard to the DIN direction!
- After installation the tip of the pressure piece must be directed towards the frame!
- For airgaps smaller or larger than 12 mm an adjustment is possible by turning the plastic part to the left or to the right!

See figure: Interlocking rod MK (horizontal)

- Mount interlocking rod on the underside:
 - Abut the interlocking rod (2) flush against the corner drive (1).
 - Click the interlocking rod gears into the teeth of the corner drive.
 - Press the interlocking rod into the fitting groove.
 - Screw the interlocking rod in place.
 - Tighten the screw (3) fully to release the central fastening.

 Please note! Damage to fittings. If the central fastening is not released, the locking device cannot be actuated. Use of force will lead to torsion of the fittings. Always insert the screw fully up to the stop.

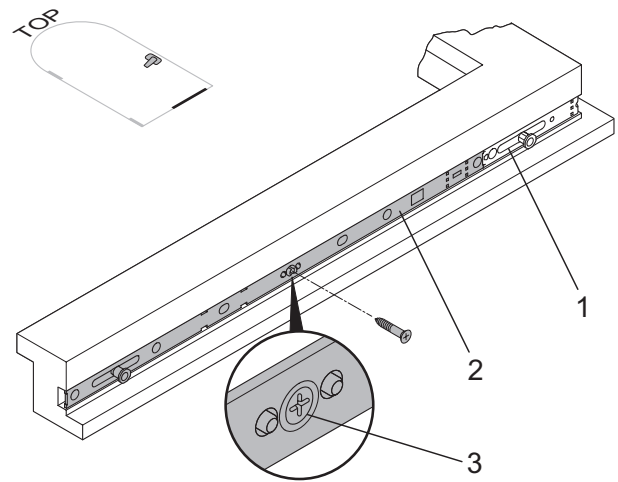

Interlocking rod MK (horizontal)

See figure: Coupling element KE (horizontal)

- Mount coupling element on the underside:
 - Abut the coupling element (2) flush against the corner drive (1) and slot into eurogroove.
 - Mark the length of the coupling element at the joint edge of the interlocking rod (3).
 - Remove the coupling element from the eurogroove.
 - Mark and trim the coupling element using a punching press.
 - Abut the coupling element (2) flush against the corner drive (1).
 - Click the coupling element into the teeth in the corner drive.
 - Slot the coupling element into the gearing of the interlocking rod (3) in the same way.
 - Press the coupling element into the eurogroove.
 - Screw the coupling element in place.

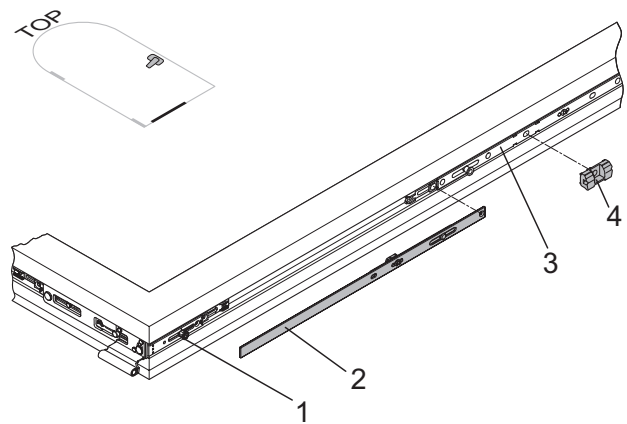

Coupling element KE (horizontal)

 Please note! Check if all screws are fixed into place on the fitting parts.

- Clip the run-up block (4) into the interlocking rod (3) and screw into place.

See figure: Interlocking rod MK

- Mount the interlocking rod MK hinge side depending on the height of FFH-R:
 - Select an interlocking rod to match the sash rebate height FFH-R and the length of connecting rod RB.
 - Fit the interlocking rod (1) flush against the corner drive (3).
 - Click the interlocking rod gears into the teeth of the corner drive.
 - Press the interlocking rod into the fitting groove.
 - Screw the interlocking rod from the bottom up.
 - Tighten the screw (2) fully to release the central fastening.

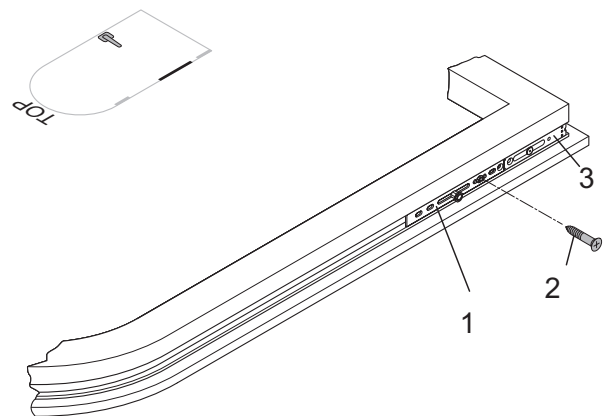

Interlocking rod MK



Please note! Damage to fittings. If the central fastening is not released, the locking device cannot be actuated. Use of force will lead to torsion of the fittings. Always insert the screw fully up to the stop.

See figure: Turn hinge DL.PADS

- Fit the turn hinge
 - Mark "FFH-R" on the sash frame.
 - Position the turn hinge (1) with the cover plate upper edge being on the "FFH-R" mark.
 - Mark the length of the turn hinge.
 - Remove the turn hinge from the fitting groove.
 - Mark and trim the turn hinge using a punching press.
 - Fit the turn hinge
 - Insert the turn hinge at the FFH-R mark. Click the gears end into the teeth of the interlocking rod or sash hinge.
 - Screw the turn hinge from top down.
 - Important: Use only screws with a minimum length of 30 mm.



Important: The cover plate must not exceed over the beginning of the radius!

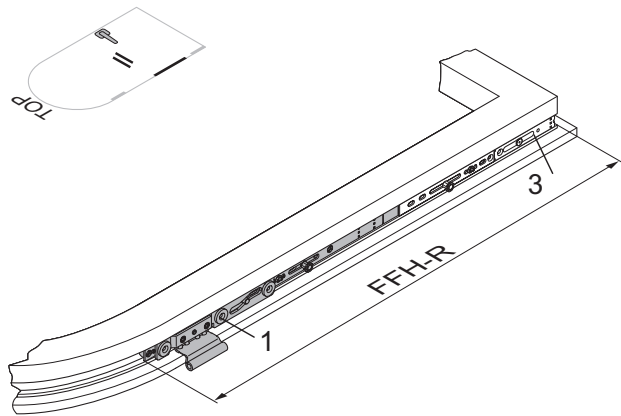

Turn hinge DL.PADS

Mounting of fittings on the window frame

Parallel opening / turn radius-head window

See figure: Drilling jig LE.B.EL-SL.K corner hinge

- Mounting the corner hinge
- Drill \varnothing 2.5 to 3 mm pilot holes for corner hinges and drill \varnothing 6 mm pilot holes for spindle plug positions.
- Drill holes for corner hinge (2) in line with mounting jig (1).
- Fit the corner hinge (2) and use screws to fasten in place in line with product instructions.

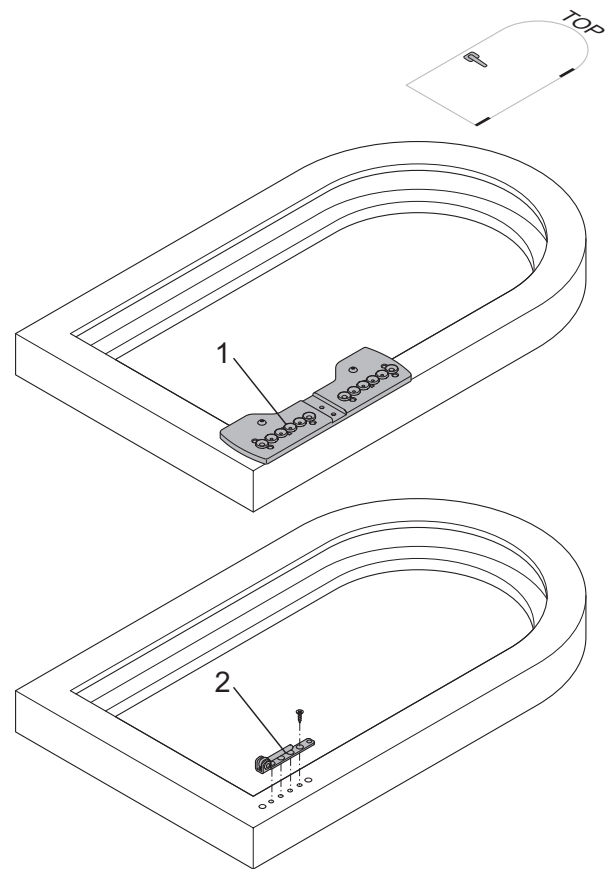

Mounting jig LE.B.EL-SL.K
 Corner hinges

See figure: Shear hinge SWR ... for round arch

- Mount the shear hinge.
- Mount the shear hinge (3) on the shear band (2) using the pin (4).
- Mount the sash.
- Place the sash on the corner hinge (5).
- Place the sash on the frame.
- Press the sash and shear hinge as far out as possible (see arrow) against the frame edge.
- Pre-drill the screw positions through the shear hinge drill holes (1) with \varnothing 2.5 to 3 mm drill.
- Screw the shear hinge into place (screws in line with details in Product Liability Information).

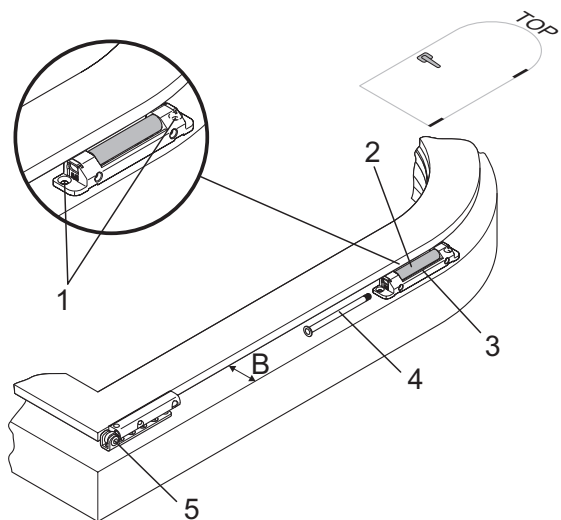

Shear hinge
 Shear hinge SWR ... for round arch

13.5

Keep positions

The following figures show the keep position options. The number of keeps depends on the size of the window.



Note: The dimensions in the drawings are for frame rebate edge to striking plate profile edge. Due to the top part of the frame not being right-angled in semicircular arched windows, it is impossible to use a mounting template to fit the keeps. This is why you need to mark the keep positions manually on the frame.

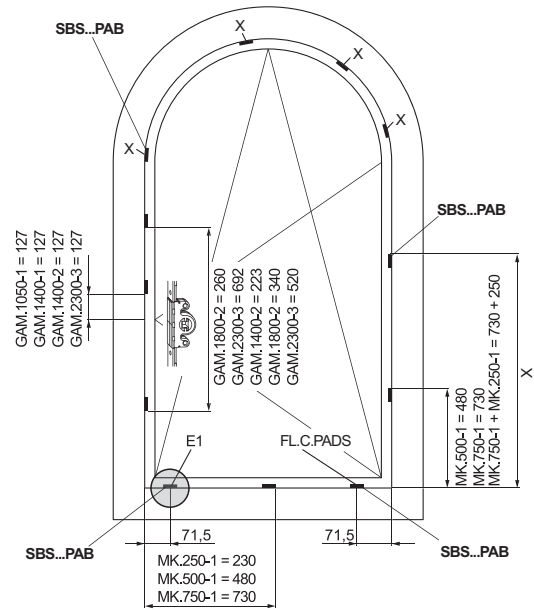

Keep positions "central handle position"
X = Dimension in elevation

- Keep position x on the round arch:

Initial situation:

- Mount the sash.
- The handle is in horizontal position; the window is unlocked so that the mushroom heads are in a central position.
- Abut the sash so that you can mark the outer edge of the mushroom bolt on the frame.

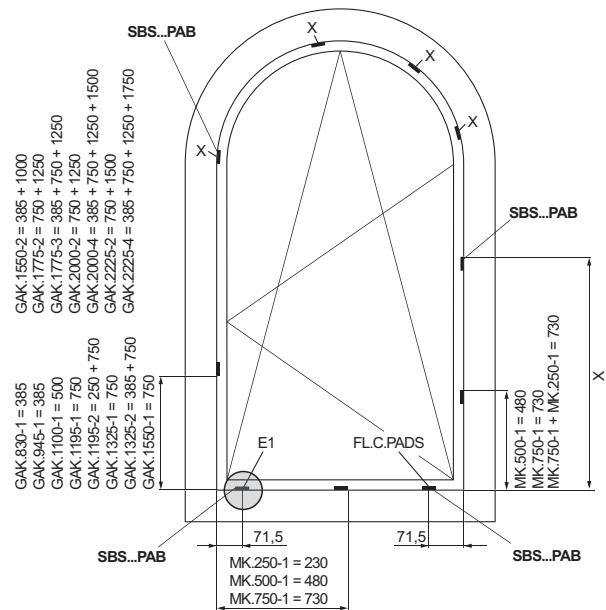

Keep position "constant handle position"
X = Dimension in elevation



Note: When marking, note the run-in sides of the keeps.

Position the keep:

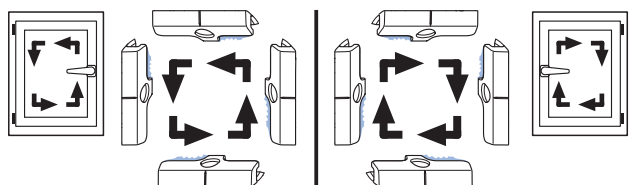

Run-in sides

Sash installation and removal

Surface-mounted hinge parts

Fitting the sash

- Mount the sash, adjust for a good seal and fit the pin to secure against the shear hinge.
- Push all end caps and sealing caps onto the shear and corner hinges.



Note: Insert the pin from the underside (see arrow).

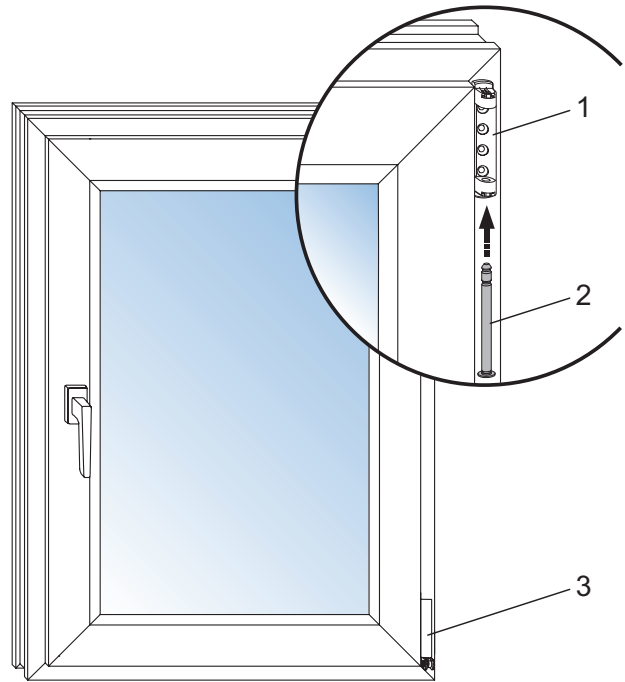

Shear and corner hinge

Removal of the sash

- Close the sash.
- Release the pin from the shear hinge.
- Remove the sash.



Please note! Damage to shear hinge. In case of improper use and if you attempt to drive out the pin forcibly, the scissor stay will be damaged. Use only a screwdriver or pin-pulling device to release the pin as shown in the figure.

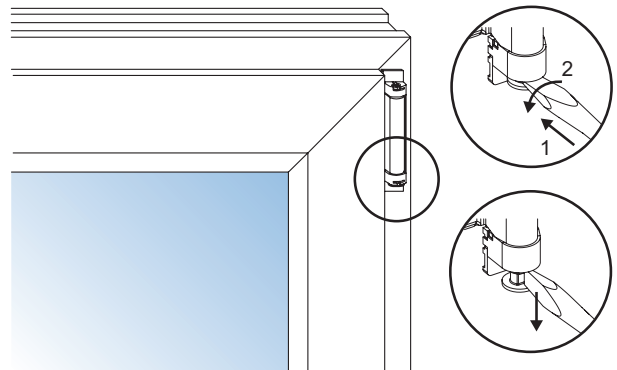

Support the sash!



In order to save the sash hinge and corner hinge from damage, sagging of the sash during assembly must be prevented (give horizontal support)!

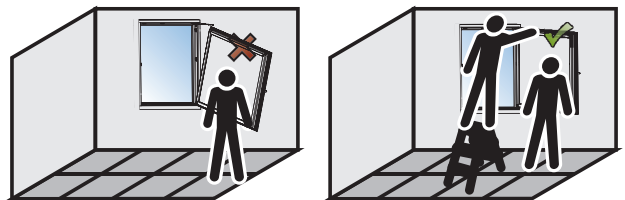

Important: Secure the window sash against falling. Take the heavy sash weight into account!

Notes on professional fitting and removing of sashes

Notes on professional mounting and dismounting of window sashes are given on our mounting advice. We recommend to place this mounting advice on the window sash.

i For withdrawing the shear hinge pin we recommend you to use the pulling device (see product page). If a screwdriver is used, please make sure that the powder coating of the hinge is not damaged.

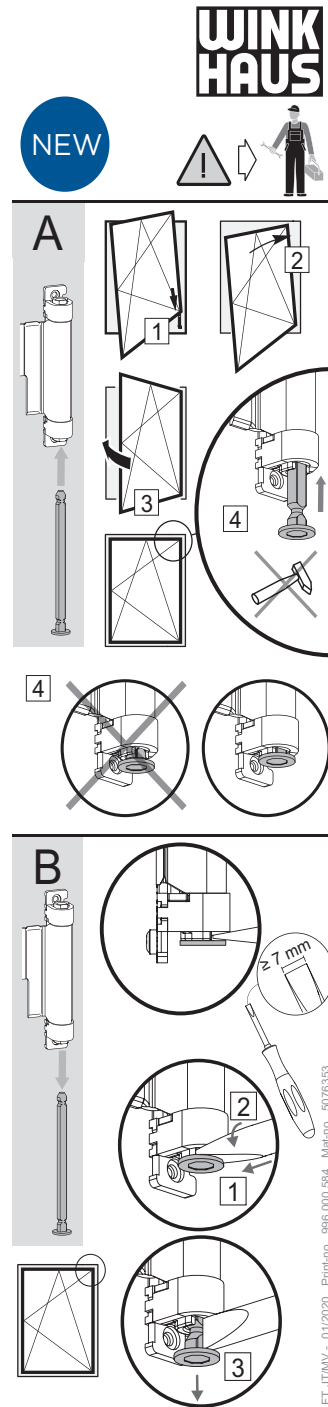

Function test / Operation

Studio and radius-head windows with parallel / turn opening

Operating sequence: locked position – turn position – parallel action

Place the handle and operate once as follows to release the central fastening.

If the handle is moved to the crosswise position from below, the fitting is in the turn position. The sash is brought into the parallel position by turning further by 90° to the 180° position. To close the window, the handle must be turned downwards to the initial position.



Note: The handle will be stiffer than normal the first time it is used. A clicking noise will be heard during actuation. Keep the window closed during actuation.

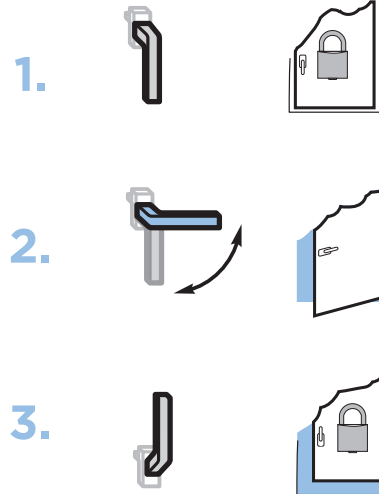
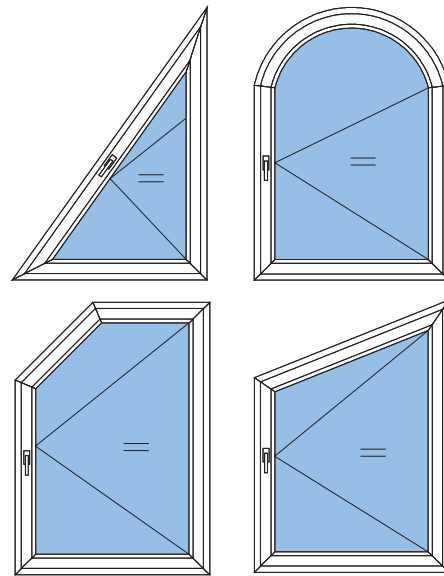

activPilot Comfort PADS – Turn and parallel opening of special window types

Technology and function description

See figure: Function SBS.K.PAB...PAS

- If the octagonal locking bolt is in position 1, the window is locked.
- If the octagonal locking bolt is in the centre (position 2), the window is in the turn position.
- If the octagonal locking bolt is in position 3, there is an opening gap of approx. 6 mm in the parallel position.

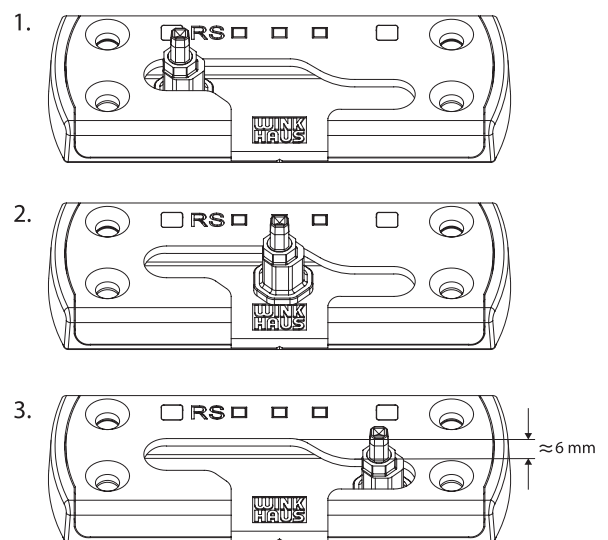

Function SBS.K.PAB...PAS

Adjustment options

Combination of corner hinge / sash hinge EL.C... and FL.C

Sash hinge without additional function

Sash hinge height adjustment (± 3 mm) and corner hinge side adjustment (± 2 mm) with 4 mm Allen key

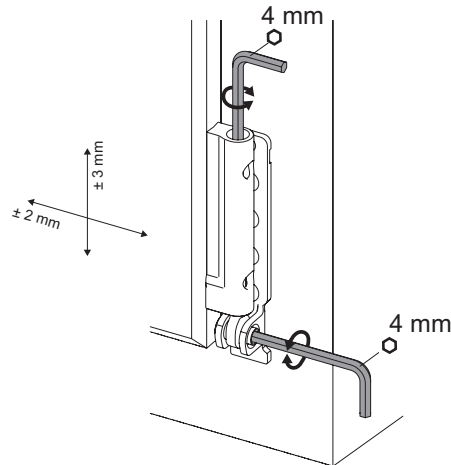

Sash hinge without additional function

Octagonal bolt

Regulate the contact pressure between the sash and the frame (± 0.8 mm) by turning the octagonal bolt. The adjustment can be carried out by means of the Winkhaus adjustment key (V.ST.SCH.HV-11).

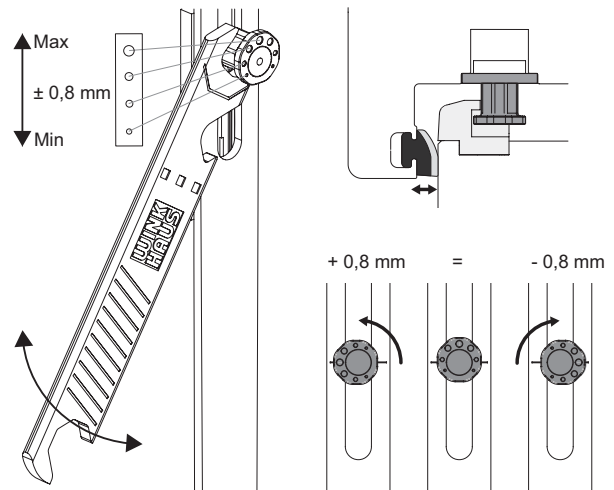

Octagonal bolt

Determining the sash inclination – Adjustment on the turn hinge

The adjustment screws may only be fitted until they are flush with the cover plate. This corresponds to a 2 mm adjustment.

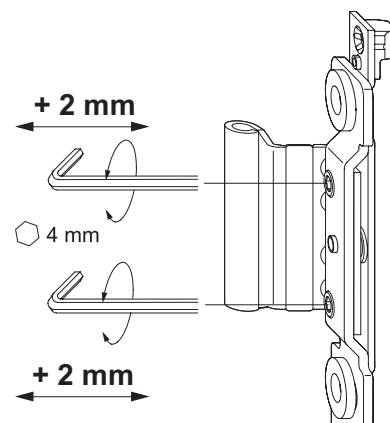
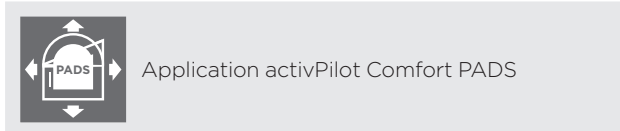

Adjustment in the turn hinge

Determining the sash inclination - Adjustment on the shear hinge

Lifting and lowering the sash by means of a 4 mm Allen key.

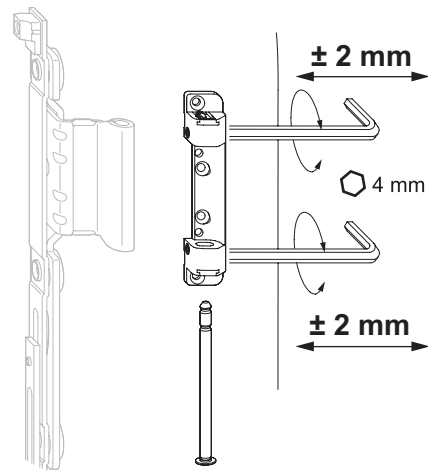
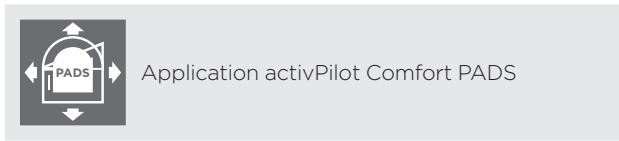

Shear hinge adjustment

Maintenance

Lubrication points

See figure: Overview of lubrication points

The figure shows the location of possible lubrication points which should be lubricated at least once a year (every six months for school and hotel buildings).

Positions A, C, D = lubrication points relevant to function.

Position B = safety-relevant lubrication point

i Note: the fitting schematic shown adjacent does not necessarily match the existing fitting. The number of locking positions will vary depending on size and type of the window sash.

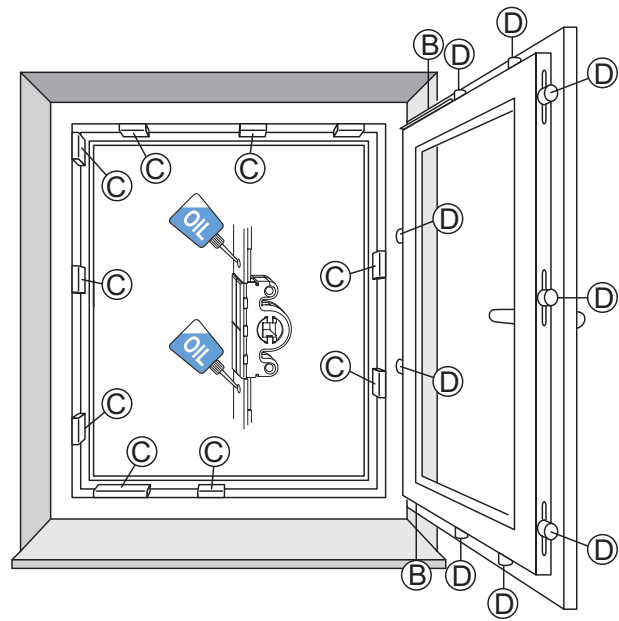

Overview of lubrication points

! Please note! Risk of injury. The window could fall on removal and thus injure persons. Do not remove the window for maintenance.

Ascertaining the run-in sides

See figure: Run-in sides

- Left-handed window; handle right
- Right-handed window; handle left

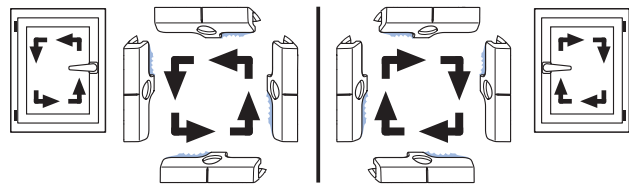

Run-in sides

Turn hinge

See figure: Turn hinge

The turn hinge's contact points should be oiled at least once annually.

i Note: The turn hinge must always be clean.

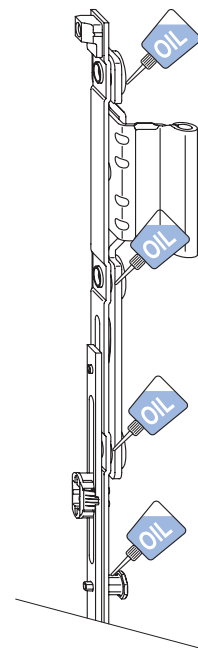

Turn hinge

Sash hinges

See figure: Sash hinges

All moving contact points on the sash hinge should be greased with a suitable lubricant once annually.

Coat lubricating points with non-resinous, non-corroding grease.

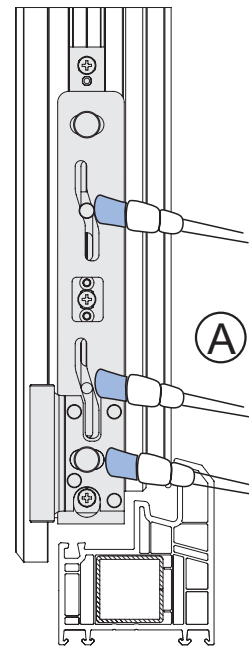

Sash hinges

Locking keeps

See figure: Locking keeps

To keep fittings running smoothly, you must lubricate the keeps at least once a year.

- Lubricate the keeps (C) at the run-in side with technical Vaseline or any other suitable grease.
- Coat the running surfaces of the locking bolts (D) with an oil that is free of resins and acids.
- Frame parts must be kept clean.

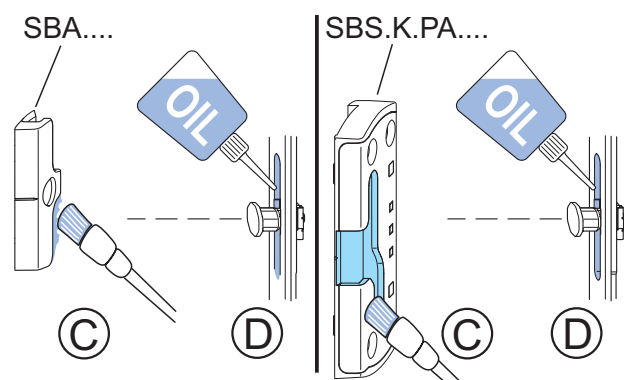

Locking keeps

Installation drawings

Drive rods

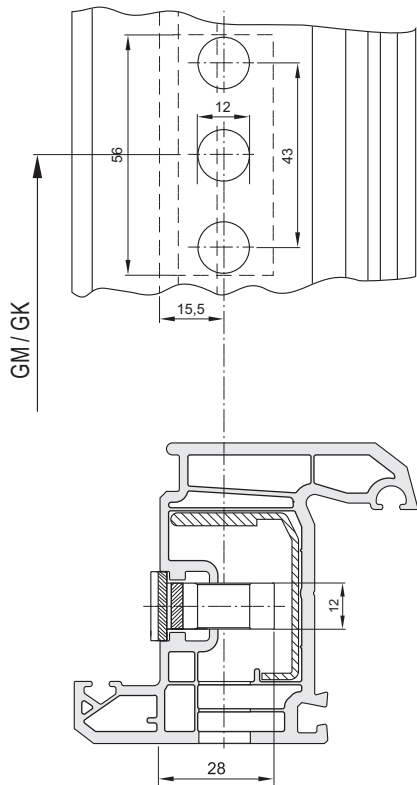

B-3-1: Drilling and milling template GAK/GAM ... D = 15.5 mm

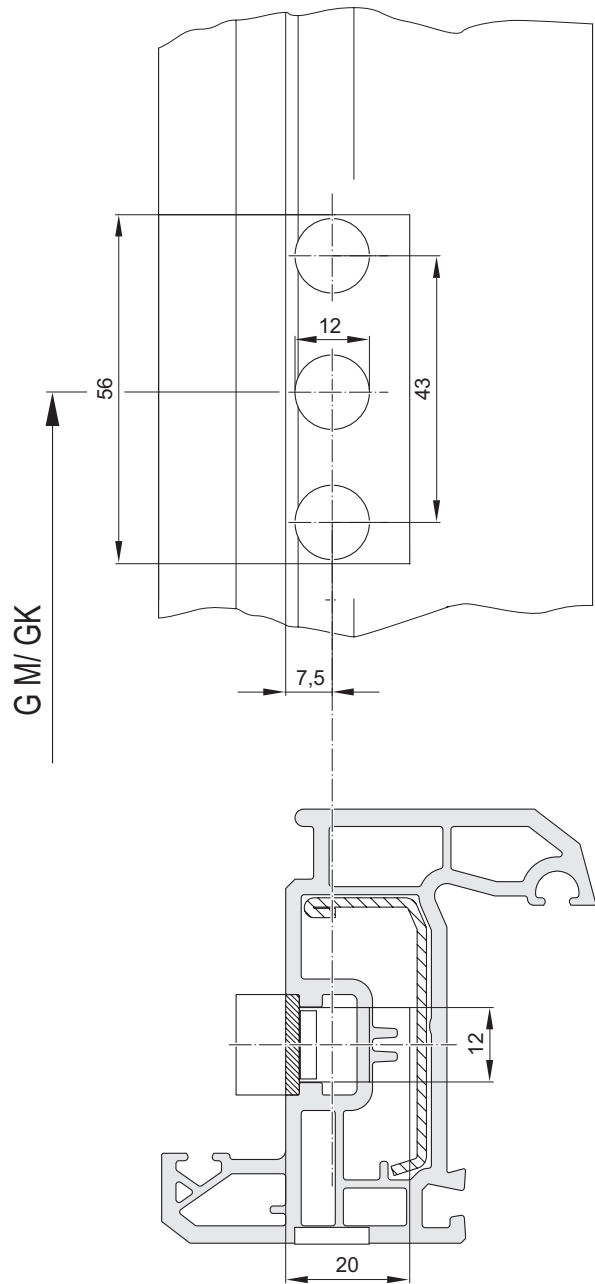

B-3-2: Drilling and milling template GAK/GAM ... D = 7.5 mm

Corner hinge EL.CS

| UEB [mm] | A [mm] | B [mm] |
|----------|--------|--------|
| 20 | 19 | 27 |
| 21 | 20 | 28 |
| 22 | 21 | 29 |

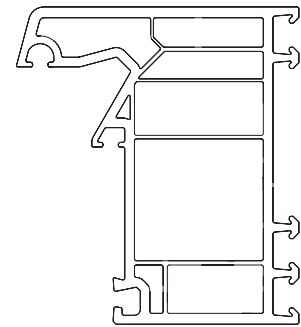

| | Ø(Z) [mm] | L(1) [mm] | L(2) [mm] |
|---------------|-----------|-----------|-----------|
| EL.CS.3-3-3 | 3 | 3 | 3 |
| EL.CS.6-3-3 | 6 | 3 | 3 |
| EL.CS.6-3-10 | 6 | 3 | 10 |
| EL.CS.6-3-22 | 6 | 3 | 22 |
| EL.CS.6-10-10 | 6 | 10 | 10 |
| EL.CS.6-22-3 | 6 | 22 | 3 |

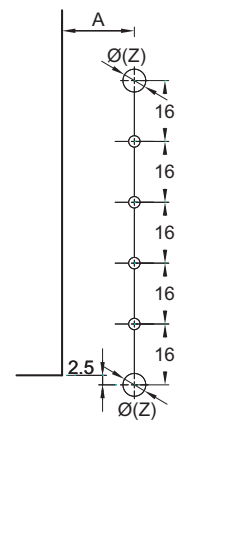
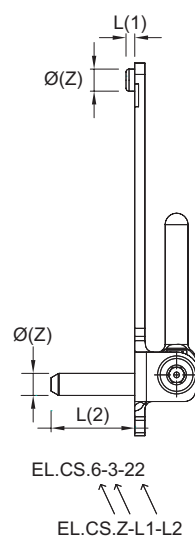
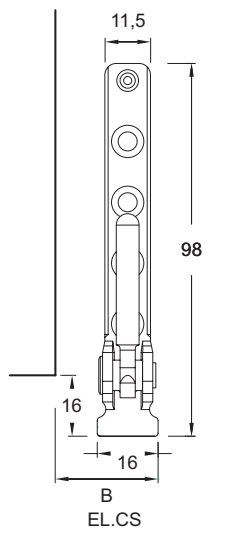
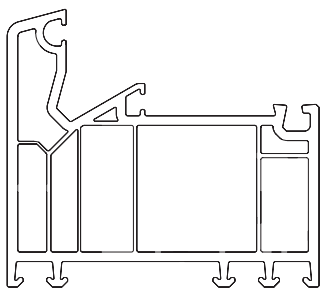

B-6-2: Drilling template corner hinge EL.CS
UEB = overlap

Shears / shear hinges

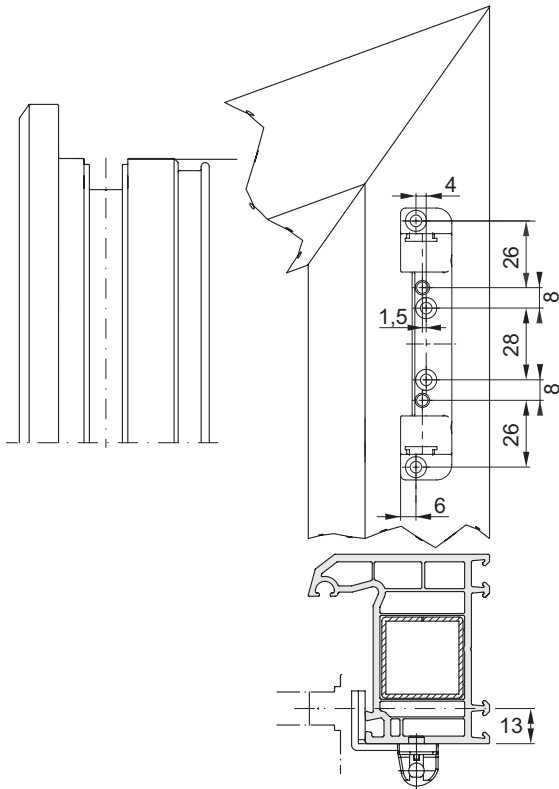

Drilling template shear hinge SWR
X = Positioning via the turn hinge

| | | Page | |
|-----------|------------------------------------|---------|-----------|
| 1 | General product information | 253 257 | 1 |
| 2 | Lists of Fittings | 258 275 | 2 |
| 3 | Drive rods | | 3 |
| 4 | Corner drives | | 4 |
| 5 | Top rods | | 5 |
| 6 | Sash hinges/Corner hinges | 276 280 | 6 |
| 7 | Shears/Shear hinges | 281 284 | 7 |
| 8 | Turn hinges/Tilt hinges | | 8 |
| 9 | Extension rods | | 9 |
| 10 | Accessories | | 10 |
| 11 | Frame parts | 285 286 | 11 |
| 12 | Mounting accessories | | 12 |
| 13 | Installation Instructions | 287 309 | 13 |
| 14 | Adjustment/maintenance | 310 313 | 14 |
| 15 | Installation drawings | | 15 |
| 16 | activPilot Comfort PADM | | 16 |
| 17 | activPilot Comfort PADS | | 17 |
| 18 | activPilot Comfort PAD | 253 313 | 18 |

1

activPilot Comfort PAD

The turn fitting system with parallel action

activPilot Comfort PAD is a combination of many different requirements: In addition to the turn opening, the fitting enables the parallel action of the window sash by up to 6 mm as an additional window setting for draught-free room ventilation. This provides a high-level of burglary-resistance with the relevant security equipment even in this ventilation mode.

Because the user requires significantly less force to close a window opened with the turn or parallel action functions than with a tilted window, the handle on a window fitted with activPilot Comfort PAD can be mounted at a low height. This makes it easy to reach, even from a seated position, making it suitable for use in buildings designed for the elderly. The user-friendly fitting is also perfect for difficult to access windows, such as those found in halls, bathrooms or kitchens. Just like all Winkhaus fittings, activPilot Comfort PAD is particularly manufacturer-friendly.

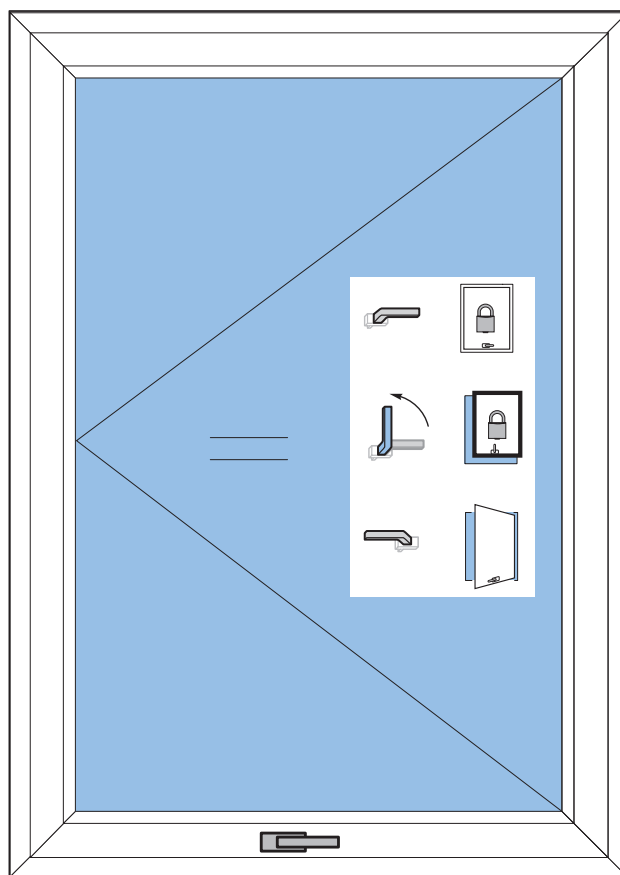
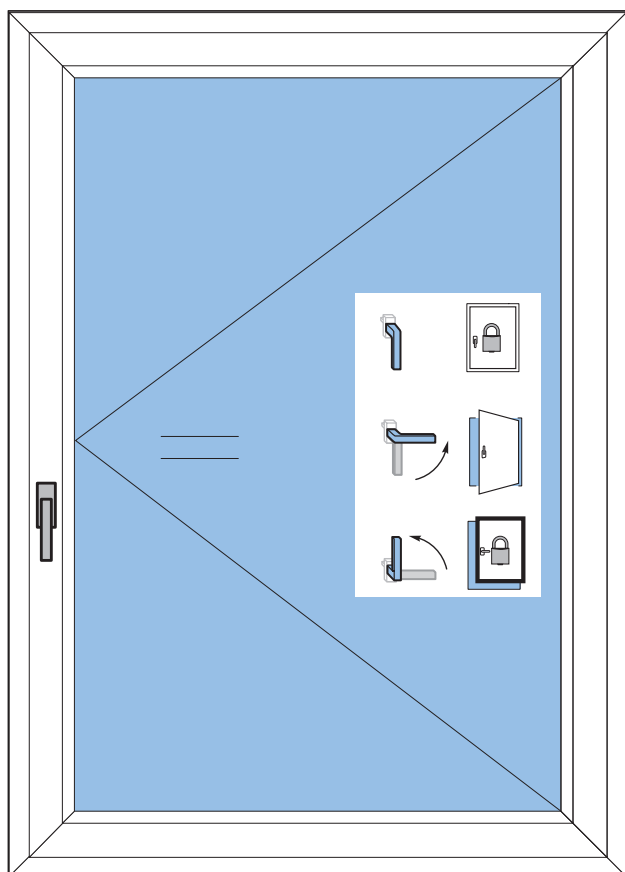

activPilot Comfort PAD

Application diagram for ascertaining the admissible sash sizes

Max. sash weight 100 kg

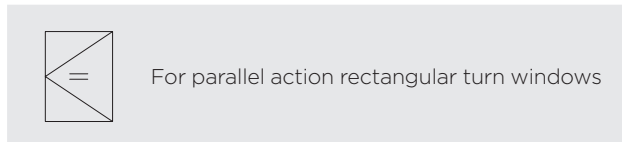
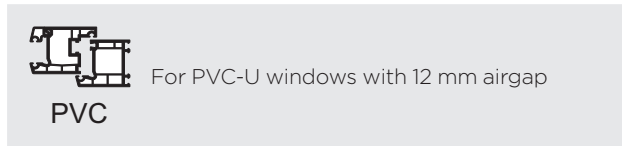

Width-to-height ratio and additional load

Value calculated without additional load for a width-to-height ratio of 1.5:1.

The application graphs have been calculated without additional loads. Please consult your authorised contact person for further information on how to calculate the maximum permissible window sash format with an additional load.

Advice for use

The application range permitted for using Winkhaus fitting is highlighted in grey in the application graphs. However, it is essential not to use the entire grey-highlighted section, but only those parts which are on the left-hand side of the curve for the respective GG filling weight.

Application range

The respective overall fitting must be selected from the original Winkhaus activPilot fitting components range. Winkhaus accepts no liability if non-original or unauthorised system accessory parts are used.

- Min. sash rebate width 460 mm
- Max. sash rebate width 1475 mm
- Min. sash rebate height 695 mm
- Max. sash rebate height 2300 mm
- Max. sash size 2.5 m²
- Max. sash weight 100 kg
- Aspect FFB/FFH ≤ 1.5:1
- Airgap 12 mm
- Groove centre position 13 mm
- Frame rebate depth min. 29 mm
- Approved for centre gasket systems and rebate sealing systems with rain guard.



Note: activPilot Comfort fittings are not suitable for use in panic doors! They are not recommended for passage doors.

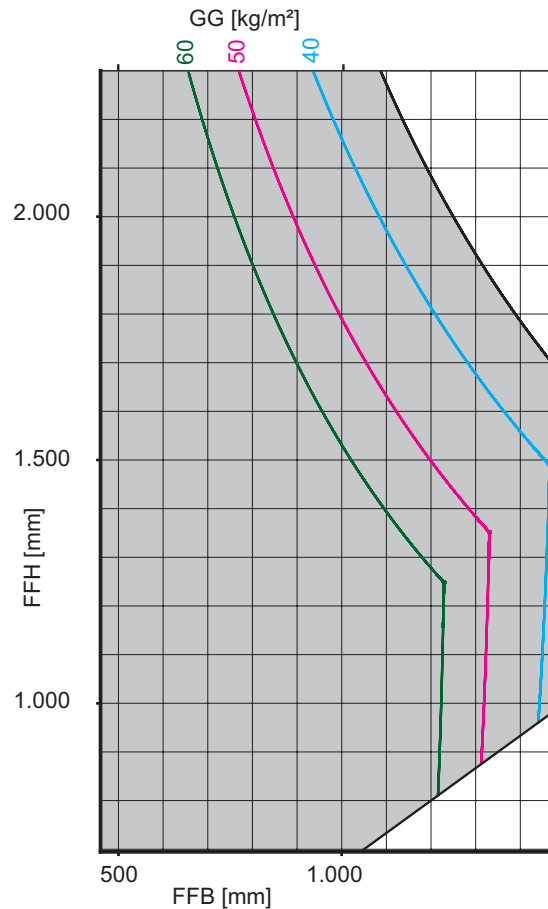

AWD_01.50_NR15_DK_100 kg_ohne_Zusatzlast_1,5_1475_m

Abbreviations

- FFB = Sash rebate width [mm]
- FFH = Sash rebate height [mm]
- GG = Glass weight per square metre [kg/m²]

Observe instructions on window profile

You must specifically take into account information provided by the profile manufacturer or system owner when determining the maximum sash sizes and sash weights!



Important: The screw connections of the load-bearing fitting components, such as corner, shear and sash hinges must be performed according to the TBDK guidelines. Adapt the drilling diameter for the fixing screws, the screw diameter and the screw length to the load situation.

System Testing RC2 (Resistance Class 2)

The RC2 processing details can be gathered from the RC2 system tests. The RC2 fitting lists in this catalogue are only application examples. Get in touch with your Winkhaus contact partner for more details.

1

Winkhaus activPilot Comfort PAD low windows

Application diagram for ascertaining the admissible sash sizes

Max. sash weight 40 kg



PVC

For PVC-U windows with 12 mm airgap



For parallel action rectangular turn windows

Width-to-height ratio and additional load

Value calculated without additional load for a width-to-height ratio of 2.5:1

The application graphs have been calculated without additional loads. Please consult your authorised contact person for further information on how to calculate the maximum permissible window sash format with an additional load.

Advice for use

The application range permitted for using Winkhaus fitting is highlighted in grey in the application graphs. However, it is essential not to use the entire grey-highlighted section, but only those parts which are on the left-hand side of the curve for the respective GG filling weight.

Application range

The respective overall fitting must be selected from the original Winkhaus activPilot fitting components range. Winkhaus accepts no liability if non-original or unauthorised system accessory parts are used.

- Min. sash rebate width 460 mm
- Max. sash rebate width 1200 mm
- Min. sash rebate height 380 mm
- Max. sash rebate height 710 mm
- Max. sash size 0.9 m²
- Max. sash weight 40 kg
- Width-to-height ratio $\leq 2.5:1$
- Airgap 12 mm
- Groove centre position 13 mm
- Frame rebate depth min. 29 mm
- Approved for centre gasket systems and rebate sealing systems with rain guard.



Note: No fail-safe device is necessary for this fitting solution!



Note: activPilot Comfort fittings are not suitable for use in panic doors! They are not recommended for passage doors.

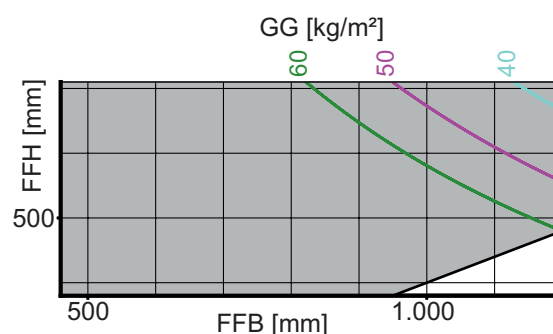

AWD_01.50_NRxx_PAD_40 kg_ohne_Zusatzlast_2,5_1

Abbreviations

- FFB = Sash rebate width [mm]
- FFH = Sash rebate height [mm]
- GG = Glass weight per square metre [kg/m²]

Observe instructions on window profile

You must specifically take into account information provided by the profile manufacturer or system owner when determining the maximum sash sizes and sash weights!



Important: The screw connections of the load-bearing fitting components, such as corner, shear and sash hinges must be performed according to the TBDK guidelines. Adapt the drilling diameter for the fixing screws, the screw diameter and the screw length to the load situation.

Quick orientation

Our register system allows you to quickly allocate the listed component to the item in the fitting overview drawing. The item number specifies the chapter number in which the component can be found.

2

6.4
ESV6-3-16SL

activPilot Comfort PAD

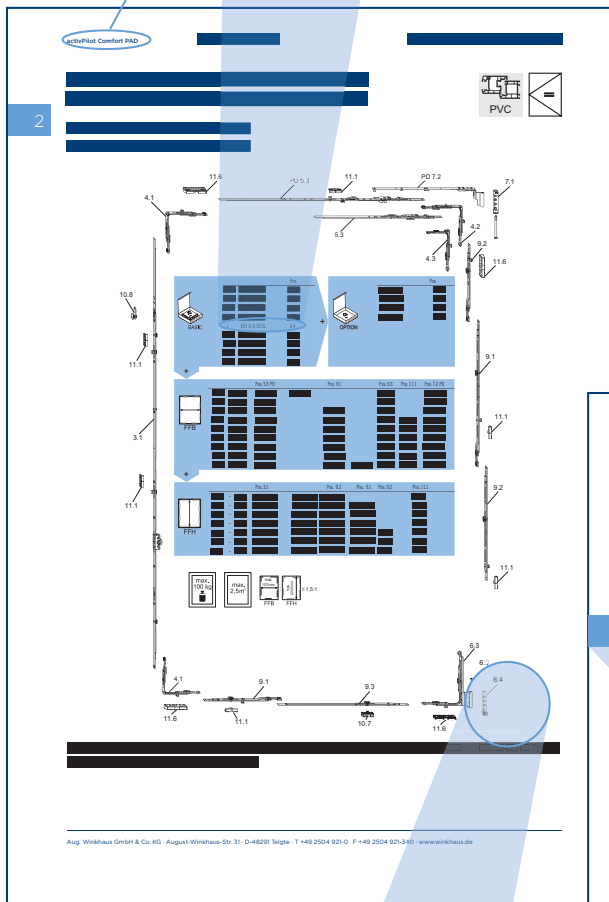

activPilot Comfort PAD

6

| Item No. | Item Name | QTY | Unit | Material | Color | Accessories |
|----------|--------------------|-----|------|----------|-------|---------------------------|
| 5007300 | FILE FWPA20-1LLS | 4 | 100 | 20 | 13 | 20 HK, 160 EK |
| 5007306 | FILE FWPA20-1LR5 | 4 | 100 | 20 | 13 | 20 HK, 160 EK |
| 5007303 | FILE FWPA20-1LL3F9 | 4 | 100 | 20 | 13 | 20 HK, 160 EK |
| 5007308 | FILE FWPA20-1LR3F9 | 4 | 100 | 20 | 13 | 20 HK, 160 EK |
| 5007305 | FILE FWPA20-1LL3WS | 4 | 100 | 20 | 13 | 20 HK, 160 EK |
| 5007309 | FILE FWPA20-1LR3WS | 4 | 100 | 20 | 13 | 20 HK, 160 EK |
| 2354024 | FLK FWV LS WS | | | | | 100 BL, 300 HK, 3400 EK |
| 2354036 | FLK FWV RS WS | | | | | 100 BL, 300 HK, 3400 EK |
| 2354038 | FLK FWV LS BR | | | | | 100 BL, 300 HK, 3400 EK |
| 2354039 | FLK FWV RS BR | | | | | 100 BL, 300 HK, 3400 EK |
| 4984443 | FLK FWV LS BZAH | | | | | 100 BL, 300 HK, 3400 EK |
| 4984444 | FLK FWV RS BZAH | | | | | 100 BL, 300 HK, 3400 EK |
| 2394154 | FLK FWV LS F1 | | | | | 100 BL, 300 HK, 3400 EK |
| 2394162 | FLK FWV RS F1 | | | | | 100 BL, 300 HK, 3400 EK |
| 4995023 | FLK FWV LS F3 | | | | | 100 BL, 300 HK, 3400 EK |
| 4995021 | FLK FWV RS F3 | | | | | 100 BL, 300 HK, 3400 EK |
| 2854708 | FLK FWV LS F9 | | | | | 100 BL, 300 HK, 3400 EK |
| 2854801 | FLK FWV RS F9 | | | | | 100 BL, 300 HK, 3400 EK |
| 4997445 | FLK FWV LS CW | | | | | 100 BL, 300 HK, 3400 EK |
| 4997446 | FLK FWV RS CW | | | | | 100 BL, 300 HK, 3400 EK |
| 1262457 | FLK FWV LS SW | | | | | 100 BL, 300 HK, 3400 EK |
| 1262458 | FLK FWV RS SW | | | | | 100 BL, 300 HK, 3400 EK |
| 152617 | FLS FWV WS | | | | | 500 BL, 5000 HK, 40000 EK |
| 1995420 | FLS FWV SL | | | | | 500 BL, 5000 HK, 40000 EK |
| 2954819 | FLS FWV F9 | | | | | 500 BL, 5000 HK, 40000 EK |
| 1526225 | FLS FWV BR | | | | | 500 BL, 5000 HK, 40000 EK |

Aug. Winkhaus GmbH & Co. KG · August-Winkhaus-Str. 31 · D-48291 Telgte · T +49 2504 921-0 · F +49 2504 921-340 · www.winkhaus.de

6.4

Lists of Fittings

| | |
|---|-----|
| Turn fitting system – constant handle position Basic equipment activPilot Comfort PAD | 260 |
| Turn fitting system – central handle position Basic equipment activPilot Comfort PAD | 262 |
| Turn fitting system – constant handle position Suitable for burglary-resistant windows RC2 / RC2 N activPilot Comfort PAD | 264 |
| Turn fitting system – central handle position Suitable for burglary-resistant windows RC2 / RC2 N activPilot Comfort PAD | 266 |
| Turn fitting system – constant handle position Basic equipment Bottom window handle activPilot Comfort PAD (operating sequence PADM) | 268 |
| Turn fitting system – central handle position Basic equipment Bottom window handle activPilot Comfort PAD (operating sequence PADM) | 270 |
| Turn fitting system – constant handle position Basic equipment low windows activPilot Comfort PAD | 272 |
| Turn fitting system – central handle position Basic equipment low windows activPilot Comfort PAD | 274 |

Turn fitting system - constant handle position

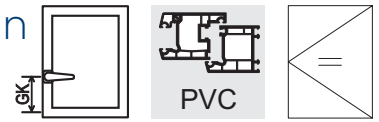

Basic equipment

activPilot Comfort PAD

2

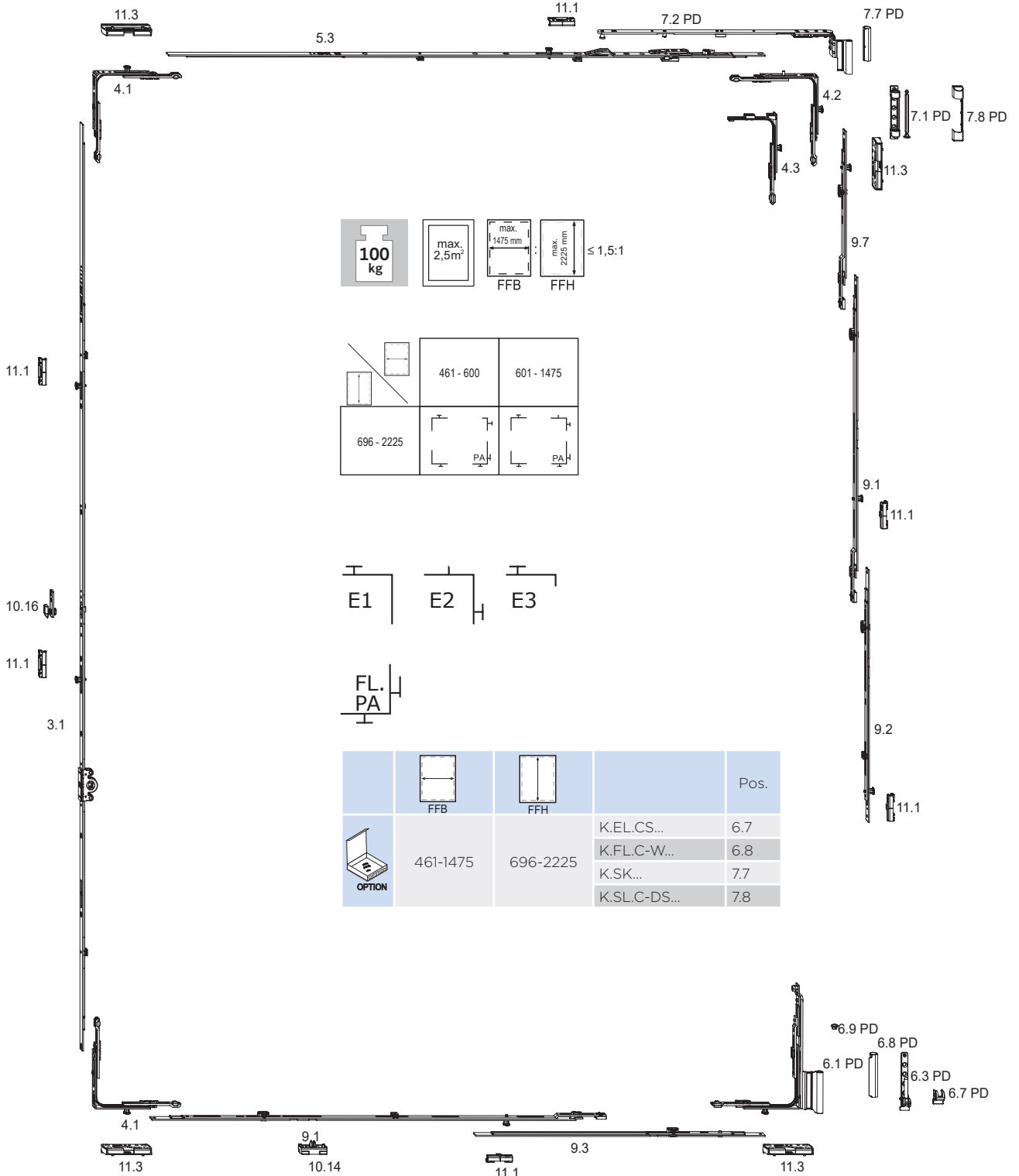

Note: You will find the components marked PD on the following pages. All other parts can be found in the activPilot Comfort PADK section.









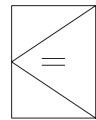
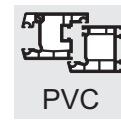
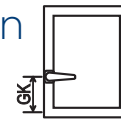

The shown distance between locking points is 800 mm.

The locking distances must be agreed with the system provider.

Turn fitting system - constant handle position

Basic equipment



| |  |  | | Pos. | | Pos. | | Pos. | | Pos. | | |
|---|---|---|-------------------|-------------|----------|-------------|-------------|-----------|----------|--------------------------|--------------|----------|
|  | 461-1475 | | 696-850 | GAK.945-1 | 3.1 | FSF | 10.16 | GK = 260 | | SBA.K... | 11.1 | 1x |
| | | | 851-1100 | GAK.1100-1 | 3.1 | FSF | 10.16 | GK = 375 | | SBA.K... | 11.1 | 1x |
| | | | 1101-1325 | GAK.1325-1 | 3.1 | FSF | 10.16 | GK = 550 | | SBA.K... | 11.1 | 1x |
| | | | 1326-1525 | GAK.1550-1 | 3.1 | FSF | 10.16 | GK = 550 | | SBA.K... | 11.1 | 1x |
| | | | 1526-1775 | GAK.1775-2 | 3.1 | FSF | 10.16 | GK = 550 | | SBA.K... | 11.1 | 2x |
| | | | 1776-2000 | GAK.2000-2 | 3.1 | FSF | 10.16 | GK = 1050 | | SBA.K... | 11.1 | 2x |
| | | | 2001-2225 | GAK.2225-2 | 3.1 | FSF | 10.16 | GK = 1050 | | SBA.K... | 11.1 | 2x |
|  | 461-1475 | 696-2225 | E1 | 4.1 | | | | | | SBS...PAB... | 11.3 | 1x |
|  | 461-600 | 696-2225 | OS1.600 | 5.3 | | | | | | | | |
| | 601-800 | | OS2.800 | 5.3 | | | | | | | | |
| | 801-1025 | | OS2.1025-1 | 5.3 | | | | | | SBA.K... | 11.1 | 1x |
| | 1026-1250 | | OS2.1250-1 | 5.3 | | | | | | SBA.K... | 11.1 | 1x |
| | 1251-1475 | | OS2.1475-1 | 5.3 | | | | | | SBA.K... | 11.1 | 1x |
|  | 461-600 | 696-2225 | E3 | 4.3 | SL.C... | 7.1 | SC1... | 7.2 | | | | |
| | 601-1475 | | E2 | 4.2 | SL.C... | 7.1 | SC2... | 7.2 | | | | |
|  | 461-1475 | | 696-850 | MK.PA.250-1 | 9.7 | | | | | SBS...PAB... | 11.3 | 1x |
| | | | 851-1075 | M.250-1 | 9.2 | MK.PA.250-1 | 9.7 | | | SBA.K... SBS...PAB... | 11.1 11.3 | 1x 1x |
| | | | 1076-1525 | M.500-1 | 9.2 | MK.PA.250-1 | 9.7 | | | SBA.K... SBS...PAB... | 11.1 11.3 | 1x 1x |
| | | | 1526-1800 | MK.500-1 | 9.1 | MK.PA.250-1 | 9.7 | M.500-1 | 9.2 | SBA.K... SBS...PAB... | 11.1 11.3 | 2x 1x |
| | | | 1801-2225 | MK.500-1 | 9.1 | MK.PA.250-1 | 9.7 | M.750-1 | 9.2 | SBA.K... SBS...PAB... | 11.1 11.3 | 2x 1x |
|  | 461-1475 | 696-2225 | FL.C.PADK... | 6.1 | EL.CS... | 6.3 | S.FL.C-W... | 6.9 | | SBS...PAB... | 11.3 | 1x |
|  | 461-710 | 696-2225 | KE SL | 9.3 | AL.M... | 10.14 | | | | | | |
| | 711-960 | | KE SL | 9.3 | AL.M... | 10.14 | MK.250-1 | 9.1 | SBA.K... | 11.1 | 1x | |
| | 961-1210 | | KE SL | 9.3 | AL.M... | 10.14 | MK.500-1 | 9.1 | SBA.K... | 11.1 | 1x | |
| | 1211-1460 | | KE SL | 9.3 | AL.M... | 10.14 | MK.750-1 | 9.1 | SBA.K... | 11.1 | 1x | |
| | 1461-1475 | | KE SL MK.500-1 | 9.3 9.1 | AL.M... | 10.14 | MK.500-1 | 9.1 | SBA.K... | 11.1 | 2x | |
|  | 461-1475 | 696-2225 | E1 | 4.1 | | | | | | SBS...PAB... | 11.3 | 1x |

Turn fitting system - central handle position

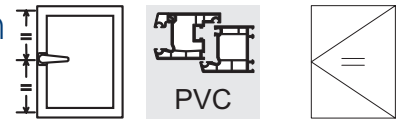

Basic equipment

activPilot Comfort PAD

2

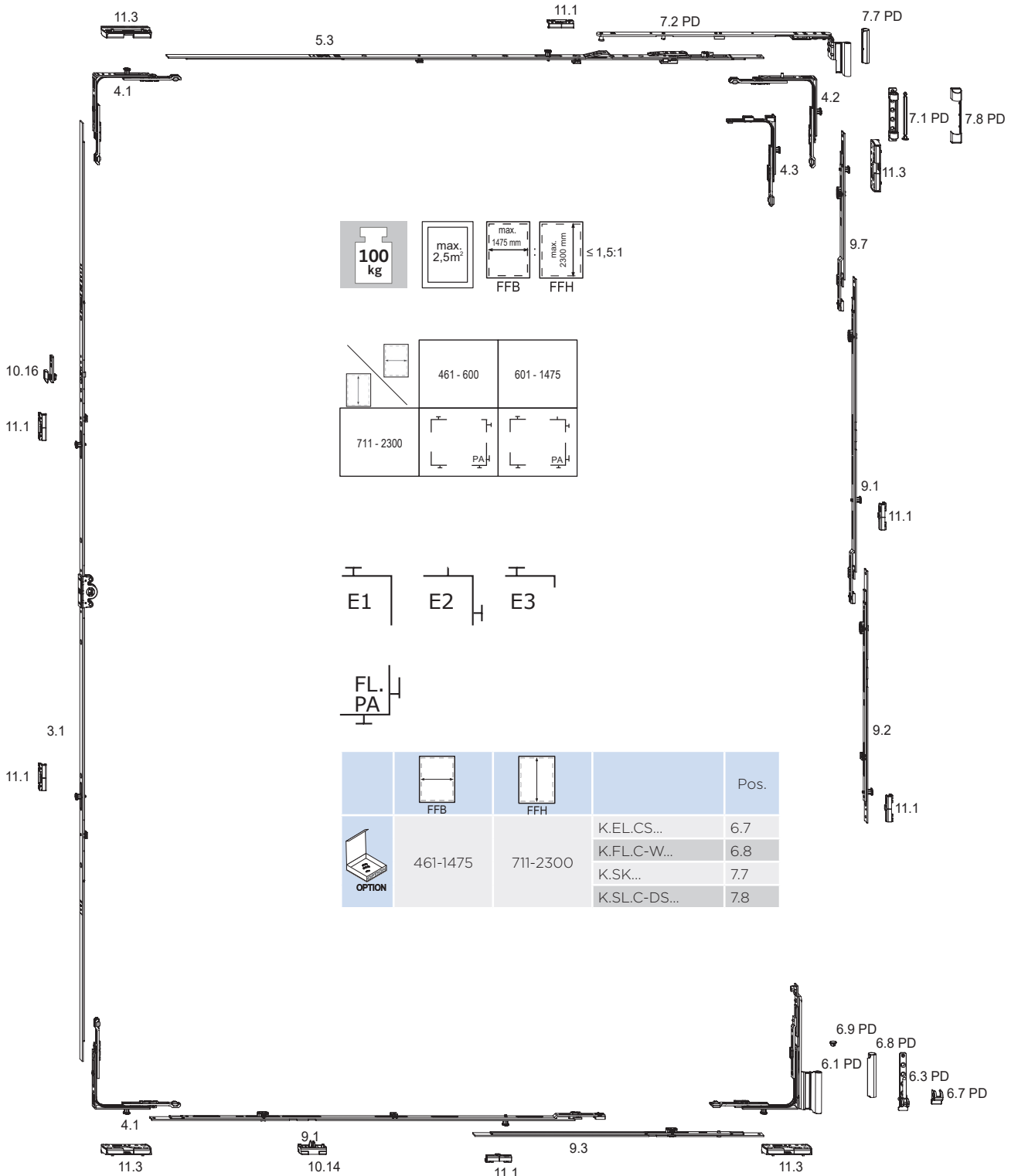

Note: You will find the components marked PD on the following pages. All other parts can be found in the activPilot Comfort PADK section.

The shown distance between locking points is 800 mm.







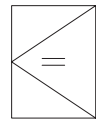
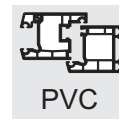
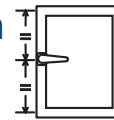



The locking distances must be agreed with the system provider.

Turn fitting system - central handle position

Basic equipment



2

| |  |  | | Pos. | | Pos. | | Pos. | | Pos. | |
|---|---|---|-------------------|------------|-------------|-------|-------------|------|--------------|------|----|
|  | 461-1475 | 711-980 | GAM.1050-1 | 3.1 | FSF | 10.16 | | | SBA.K... | 11.1 | 1x |
| | | 981-1400 | GAM.1400-1 | 3.1 | FSF | 10.16 | | | SBA.K... | 11.1 | 1x |
| | | 1401-1800 | GAM.1800-2 | 3.1 | FSF | 10.16 | | | SBA.K... | 11.1 | 2x |
| | | 1801-2300 | GAM.2300-3 | 3.1 | FSF | 10.16 | | | SBA.K... | 11.1 | 3x |
|  | 461-1475 | 711-2300 | E1 | 4.1 | | | | | SBS...PAB... | 11.3 | 1x |
|  | 461-600 | 711-2300 | OS1.600 | 5.3 | | | | | | | |
| | 601-800 | | OS2.800 | 5.3 | | | | | | | |
| | 801-1025 | | OS2.1025-1 | 5.3 | | | | | SBA.K... | 11.1 | 1x |
| | 1026-1250 | | OS2.1250-1 | 5.3 | | | | | SBA.K... | 11.1 | 1x |
| | 1251-1475 | | OS2.1475-1 | 5.3 | | | | | SBA.K... | 11.1 | 1x |
|  | 461-600 | 711-2300 | E3 | 4.3 | S.L.C... | 7.1 | SC1... | 7.2 | | | |
| | 601-1475 | | E2 | 4.2 | S.L.C... | 7.1 | SC2... | 7.2 | | | |
|  | 461-1475 | 711-850 | MK.PA.250-1 | 9.7 | | | | | SBS...PAB... | 11.3 | 1x |
| | | 851-1075 | M.250-1 | 9.2 | MK.PA.250-1 | 9.7 | | | SBA.K... | 11.1 | 1x |
| | | 1076-1525 | M.500-1 | 9.2 | MK.PA.250-1 | 9.7 | | | SBA.K... | 11.1 | 1x |
| | | 1526-1800 | MK.500-1 | 9.1 | MK.PA.250-1 | 9.7 | M.500-1 | 9.2 | SBA.K... | 11.1 | 2x |
| | | 1801-2300 | MK.500-1 | 9.1 | MK.PA.250-1 | 9.7 | M.750-1 | 9.2 | SBA.K... | 11.1 | 2x |
|  | 461-1475 | 711-2300 | FL.C.PADK... | 6.1 | EL.CS... | 6.3 | S.FL.C-W... | 6.9 | SBS...PAB... | 11.3 | 1x |
|  | 461-710 | 711-2300 | KE SL | 9.3 | AL.M... | 10.14 | | | | | |
| | 711-960 | | KE SL | 9.3 | AL.M... | 10.14 | MK.250-1 | 9.1 | SBA.K... | 11.1 | 1x |
| | 961-1210 | | KE SL | 9.3 | AL.M... | 10.14 | MK.500-1 | 9.1 | SBA.K... | 11.1 | 1x |
| | 1211-1460 | | KE SL | 9.3 | AL.M... | 10.14 | MK.750-1 | 9.1 | SBA.K... | 11.1 | 1x |
| | 1461-1475 | | KE SL MK.500-1 | 9.3 9.1 | AL.M... | 10.14 | MK.500-1 | 9.1 | SBA.K... | 11.1 | 2x |
|  | 461-1475 | 711-2300 | E1 | 4.1 | | | | | SBS...PAB... | 11.3 | 1x |

Turn fitting system - constant handle position

Suitable for burglary-resistant windows RC2 / RC2 N
activPilot Comfort PAD

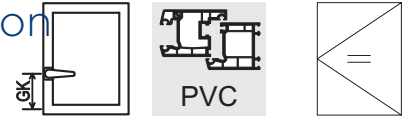

2

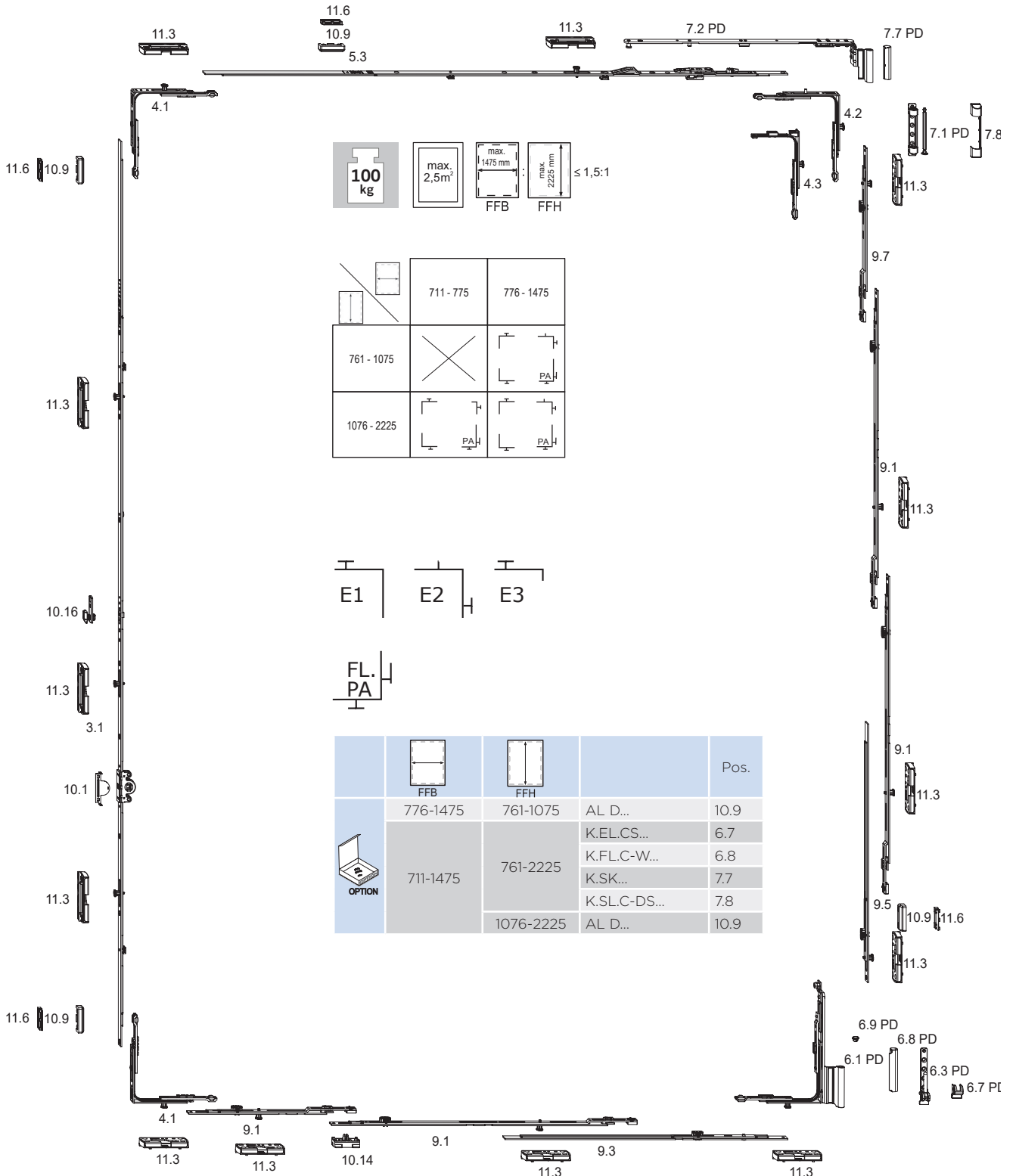

Note: You will find the components marked PD on the following pages. All other parts can be found in the activPilot Comfort PADK section.









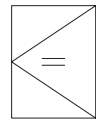
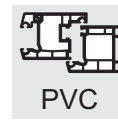
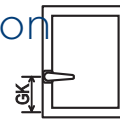



The shown distance between locking points is 800 mm.

The locking distances must be agreed with the system provider.

Turn fitting system - constant handle position

Suitable for burglary-resistant windows RC2 / RC2 N



| |  |  | | Pos. | | Pos. | | Pos. | | Pos. | |
|---|--|---|--------------|------------|-------------|----------|--------------|--------------|--------------|------|----|
|  |  711-1475 | 761-2225 | AB.G.D.15,5 | 10.1 | | | | | | | |
| | 776-1475 | 761-850 | GAK.945-1 | 3.1 | FSF | 10.16 | | | SBS...PAB... | 11.3 | 1x |
| | | 851-1075 | GAK.1100-1 | 3.1 | FSF | 10.16 | | | SBS...PAB... | 11.3 | 1x |
| | 711-1475 | 1076-1325 | GAK.1325-2 | 3.1 | FSF | 10.16 | | | SBS...PAB... | 11.3 | 2x |
| | | 1326-1525 | GAK.1550-2 | 3.1 | FSF | 10.16 | | | SBS...PAB... | 11.3 | 2x |
| | | 1526-1775 | GAK.1775-3 | 3.1 | FSF | 10.16 | | | SBS...PAB... | 11.3 | 3x |
| | | 1776-2000 | GAK.2000-4 | 3.1 | FSF | 10.16 | | | SBS...PAB... | 11.3 | 4x |
| | | 2001-2225 | GAK.2225-4 | 3.1 | FSF | 10.16 | | | SBS...PAB... | 11.3 | 4x |
|  |  711-1475 | 761-2225 | E1 | 4.1 | | | | | SBS...PAB... | 11.3 | 1x |
|  | 711-775 | 1076-2225 | OS1.600 | 5.3 | MK.250-1 | 9.1 | | | SBS...PAB... | 11.3 | 1x |
| | 776-1025 | 761-2225 | OS2.1025-1 | 5.3 | | | | | SBS...PAB... | 11.3 | 1x |
| | 1026-1250 | | OS2.1250-1 | 5.3 | | | | | SBS...PAB... | 11.3 | 1x |
| | 1251-1475 | OS2.1250-1 | 5.3 | MK.250-1 | 9.1 | | | SBS...PAB... | 11.3 | 2x | |
|  | 711-775 | 1076-2225 | E3 | 4.3 | SL.C... | 7.1 | SC1... | 7.2 | | | |
| | 776-1475 | 761-2225 | E2 | 4.2 | SL.C... | 7.1 | SC2... | 7.2 | | | |
|  | 776-1475 | 761-1010 | MK.PA.250-1 | 9.7 | V.AK.450-1 | 9.5 | | | SBS...PAB... | 11.3 | 2x |
| | | 1011-1075 | MK.250-1 | 9.1 | MK.PA.250-1 | 9.7 | V.AK.450-1 | 9.5 | SBS...PAB... | 11.3 | 3x |
| | 711-1475 | 1076-1260 | MK.250-1 | 9.1 | MK.PA.250-1 | 9.7 | V.AK.450-1 | 9.5 | SBS...PAB... | 11.3 | 3x |
| | | 1261-1510 | MK.500-1 | 9.1 | MK.PA.250-1 | 9.7 | V.AK.450-1 | 9.5 | SBS...PAB... | 11.3 | 3x |
| | | 1511-1760 | MK.250-1 | 9.1 | MK.PA.250-1 | 9.7 | MK.500-1 | 9.1 | SBS...PAB... | 11.3 | 4x |
| | | | V.AK.450-1 | 9.5 | | | | | | | |
| | | 1761-2010 | MK.500-1 | 9.1 | MK.PA.250-1 | 9.7 | MK.500-1 | 9.1 | SBS...PAB... | 11.3 | 4x |
| | | | V.AK.450-1 | 9.5 | | | | | | | |
| 2011-2225 | MK.250-1 | 9.1 | MK.PA.250-1 | 9.7 | MK.500-1 | 9.1 | SBS...PAB... | 11.3 | 5x | | |
| | | MK.500-1 | 9.1 | V.AK.450-1 | 9.5 | | | | | | |
|  | 776-1475 | 761-1075 | FL.C.PADK... | 6.1 | EL.CS... | 6.3 | S.FL.C-W... | 6.9 | SBS...PAB... | 11.3 | 1x |
| | 711-1475 | 1076-2225 | FL.C.PADK... | 6.1 | EL.CS... | 6.3 | S.FL.C-W... | 6.9 | SBS...PAB... | 11.3 | 1x |
|  | 711-960 | 1076-2225 | KE SL | 9.3 | AL.M... | 10.14 | MK.250-1 | 9.1 | SBS...PAB... | 11.3 | 1x |
| | 776-960 | 761-1075 | KE SL | 9.3 | AL.M... | 10.14 | MK.250-1 | 9.1 | SBS...PAB... | 11.3 | 1x |
| | 961-1210 | 761-2225 | KE SL | 9.3 | AL.M... | 10.14 | MK.250-1 | 9.1 | SBS...PAB... | 11.3 | 2x |
| | | | MK.250-1 | 9.1 | | | | | | | |
| | 1211-1460 | 761-2225 | KE SL | 9.3 | AL.M... | 10.14 | MK.250-1 | 9.1 | SBS...PAB... | 11.3 | 2x |
| | | | MK.500-1 | 9.1 | | | | | | | |
| 1461-1475 | 761-2225 | KE SL | 9.3 | AL.M... | 10.14 | MK.250-1 | 9.1 | SBS...PAB... | 11.3 | 3x | |
| | | MK.250-1 | 9.1 | MK.500-1 | 9.1 | | | | | | |
|  |  711-1475 | 761-2225 | E1 | 4.1 | | | | | SBS...PAB... | 11.3 | 1x |

 marks a line with items that are always used, regardless of size

Turn fitting system - central handle position

Suitable for burglary-resistant windows RC2 / RC2 N
activPilot Comfort PAD

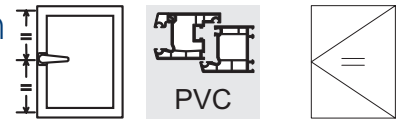

2

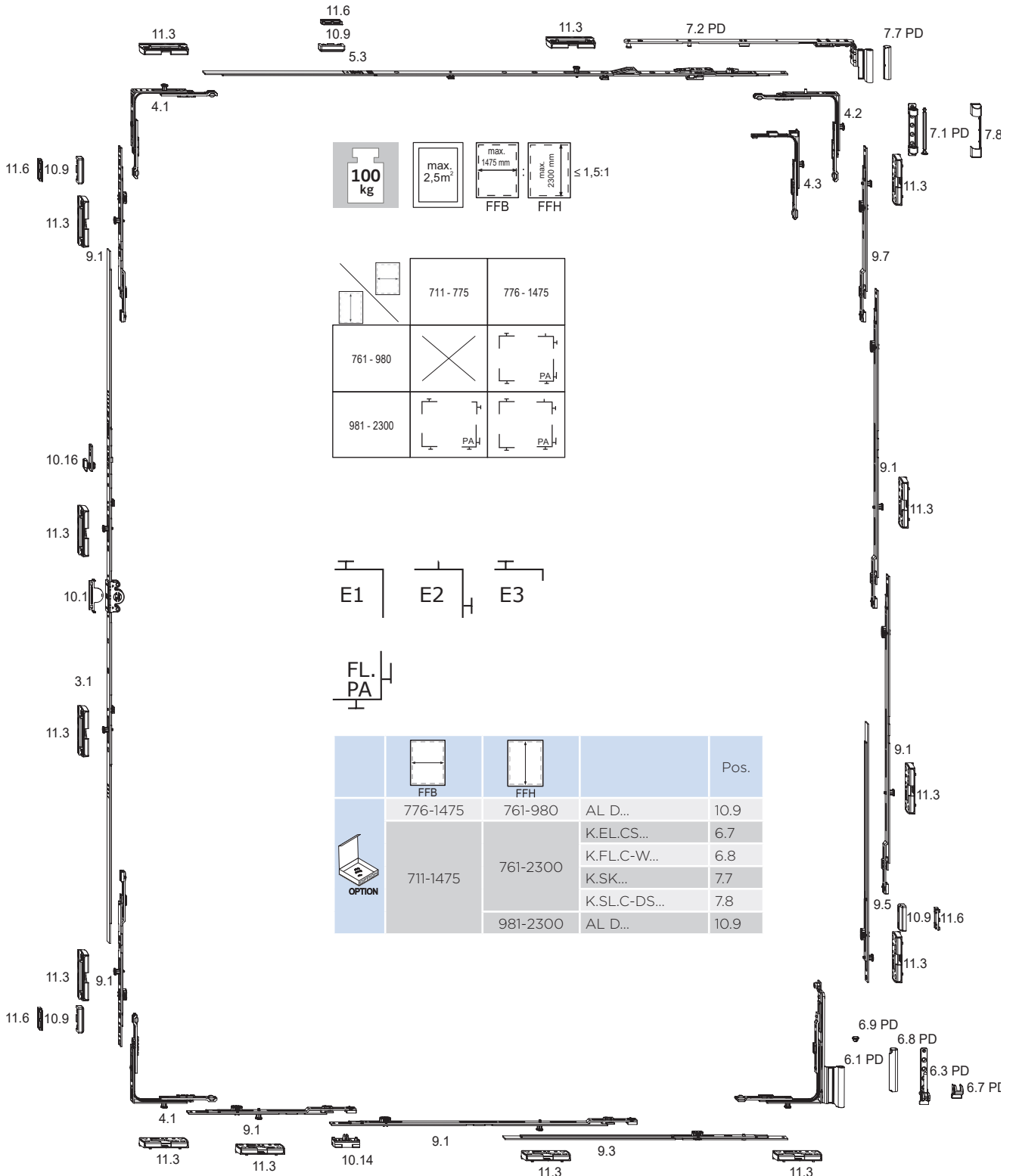

Note: You will find the components marked PD on the following pages. All other parts can be found in the activPilot Comfort PADK section.

The shown distance between locking points is 800 mm.

The locking distances must be agreed with the system provider.

Turn fitting system - central handle position

Suitable for burglary-resistant windows RC2 / RC2 N

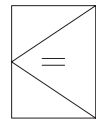
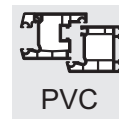
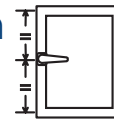

| | | | | Pos. | | Pos. | | Pos. | | Pos. | | |
|-----------|-----------|------------|--------------|-------------|------------|-------------|-------------|--------------|--------------|--------------|------|----|
| | 711-1475 | 761-2300 | AB.G.D.15,5 | 10.1 | | | | | | | | |
| | 776-1475 | 761-980 | GAM.1050-1 | 3.1 | FSF | 10.16 | | | SBS...PAB... | 11.3 | 1x | |
| | 711-1475 | 981-1300 | GAM.1400-2 | 3.1 | FSF | 10.16 | | | SBS...PAB... | 11.3 | 2x | |
| | | 1301-1600 | GAM.1800-2 | 3.1 | FSF | 10.16 | | | SBS...PAB... | 11.3 | 2x | |
| | 711-775 | 1601-1800 | GAM.1400-2 | 3.1 | FSF | 10.16 | MK.250-1 | 9.1 | SBS...PAB... | 11.3 | 4x | |
| | | | MK.250-1 | 9.1 | | | | | | | | |
| | 776-1475 | | MK.250-1 | 9.1 | GAM.1400-2 | 3.1 | FSF | 10.16 | SBS...PAB... | 11.3 | 4x | |
| | | | MK.250-1 | 9.1 | | | | | | | | |
| | 711-1475 | 1801-1900 | GAM.2300-3 | 3.1 | FSF | 10.16 | | | SBS...PAB... | 11.3 | 3x | |
| 711-775 | 1901-2300 | GAM.1400-2 | 3.1 | FSF | 10.16 | MK.500-1 | 9.1 | SBS...PAB... | 11.3 | 4x | | |
| | | MK.500-1 | 9.1 | | | | | | | | | |
| 776-1475 | | MK.500-1 | 9.1 | GAM.1400-2 | 3.1 | FSF | 10.16 | SBS...PAB... | 11.3 | 4x | | |
| | | MK.500-1 | 9.1 | | | | | | | | | |
| | 711-1475 | 761-2300 | E1 | 4.1 | | | | | SBS...PAB... | 11.3 | 1x | |
| | 711-775 | 981-2300 | OS1.600 | 5.3 | MK.250-1 | 9.1 | | | SBS...PAB... | 11.3 | 1x | |
| | 776-1025 | 761-2300 | OS2.1025-1 | 5.3 | | | | | SBS...PAB... | 11.3 | 1x | |
| | 1026-1250 | | OS2.1250-1 | 5.3 | | | | | SBS...PAB... | 11.3 | 1x | |
| | 1251-1475 | | OS2.1250-1 | 5.3 | MK.250-1 | 9.1 | | | SBS...PAB... | 11.3 | 2x | |
| | 711-775 | 981-2300 | E3 | 4.3 | SL.C... | 7.1 | SC1... | 7.2 | | | | |
| | 776-1475 | 761-2300 | E2 | 4.2 | SL.C... | 7.1 | SC2... | 7.2 | | | | |
| | 711-1475 | 776-1475 | 761-980 | MK.PA.250-1 | 9.7 | V.AK.450-1 | 9.5 | | SBS...PAB... | 11.3 | 2x | |
| | | | 981-1010 | MK.PA.250-1 | 9.7 | V.AK.450-1 | 9.5 | | SBS...PAB... | 11.3 | 2x | |
| | | | 1011-1260 | MK.250-1 | 9.1 | MK.PA.250-1 | 9.7 | V.AK.450-1 | 9.5 | SBS...PAB... | 11.3 | 3x |
| | | | 1261-1510 | MK.500-1 | 9.1 | MK.PA.250-1 | 9.7 | V.AK.450-1 | 9.5 | SBS...PAB... | 11.3 | 3x |
| | | | 1511-1760 | MK.250-1 | 9.1 | MK.PA.250-1 | 9.7 | MK.500-1 | 9.1 | SBS...PAB... | 11.3 | 4x |
| | | | | V.AK.450-1 | 9.5 | | | | | | | |
| | | | 1761-2010 | MK.500-1 | 9.1 | MK.PA.250-1 | 9.7 | MK.500-1 | 9.1 | SBS...PAB... | 11.3 | 4x |
| | | | | V.AK.450-1 | 9.5 | | | | | | | |
| | 2011-2260 | MK.250-1 | 9.1 | MK.PA.250-1 | 9.7 | MK.500-1 | 9.1 | SBS...PAB... | 11.3 | 5x | | |
| | | MK.500-1 | 9.1 | V.AK.450-1 | 9.5 | | | | | | | |
| | 2261-2300 | MK.500-1 | 9.1 | MK.PA.250-1 | 9.7 | MK.500-1 | 9.1 | SBS...PAB... | 11.3 | 5x | | |
| | | MK.500-1 | 9.1 | V.AK.450-1 | 9.5 | | | | | | | |
| | 776-1475 | 761-980 | FL.C.PADK... | 6.1 | EL.CS... | 6.3 | S.FL.C-W... | 6.9 | SBS...PAB... | 11.3 | 1x | |
| | 711-1475 | 981-2300 | FL.C.PADK... | 6.1 | EL.CS... | 6.3 | S.FL.C-W... | 6.9 | SBS...PAB... | 11.3 | 1x | |
| | 711-960 | 981-2300 | KE SL | 9.3 | AL.M... | 10.14 | MK.250-1 | 9.1 | SBS...PAB... | 11.3 | 1x | |
| | 776-960 | 761-980 | KE SL | 9.3 | AL.M... | 10.14 | MK.250-1 | 9.1 | SBS...PAB... | 11.3 | 1x | |
| | 961-1210 | 761-2300 | KE SL | 9.3 | AL.M... | 10.14 | MK.250-1 | 9.1 | SBS...PAB... | 11.3 | 2x | |
| | | | MK.250-1 | 9.1 | | | | | | | | |
| | 1211-1460 | | KE SL | 9.3 | AL.M... | 10.14 | MK.250-1 | 9.1 | SBS...PAB... | 11.3 | 2x | |
| MK.500-1 | | | 9.1 | | | | | | | | | |
| 1461-1475 | | KE SL | 9.3 | AL.M... | 10.14 | MK.250-1 | 9.1 | SBS...PAB... | 11.3 | 3x | | |
| | | MK.250-1 | 9.1 | MK.500-1 | 9.1 | | | | | | | |
| | 711-1475 | 761-2300 | E1 | 4.1 | | | | | SBS...PAB... | 11.3 | 1x | |

marks a line with items that are always used, regardless of size

Turn fitting system - constant handle position

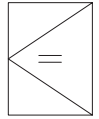
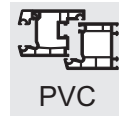

2

Basic equipment

Bottom window handle

activPilot Comfort PAD (operating sequence PADM)

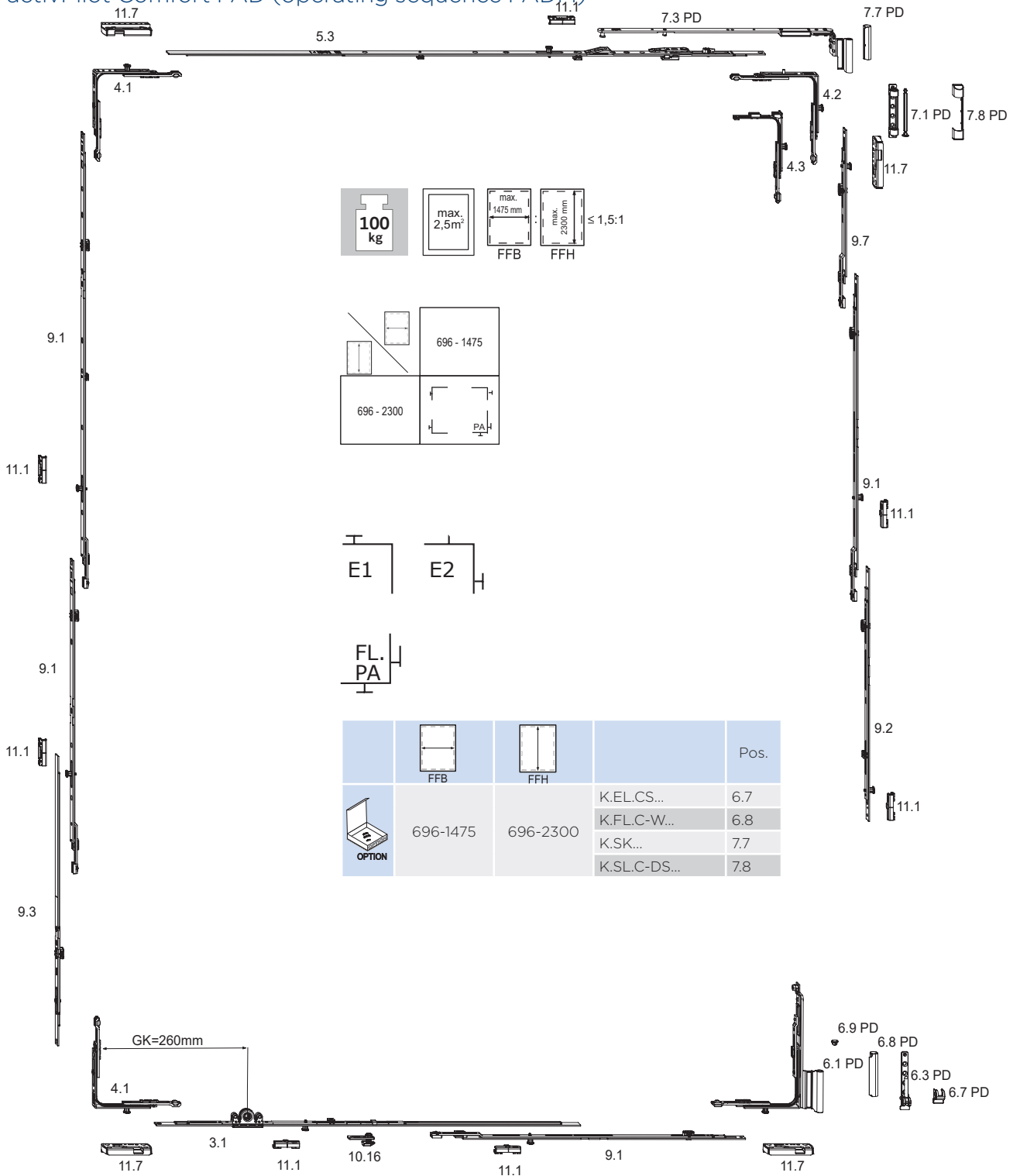

Note: You will find the components marked PD on the following pages. All other parts can be found in the activPilot Comfort PADK section.









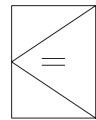
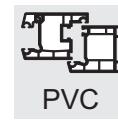

The shown distance between locking points is 800 mm.

The locking distances must be agreed with the system provider.

Turn fitting system - constant handle position

Basic equipment



| |  |  | | Pos. | | Pos. | | Pos. | | Pos. | |
|---|---|---|--------------|------|-------------|-------|------------|------|--------------------------|--------------|----------|
|  | 696-710 | 696-2300 | GAK.945-1 | 3.1 | FSF | 10.16 | | | SBA.K... | 11.1 | 1x |
| | 711-945 | | GAK.945-1 | 3.1 | FSF | 10.16 | | | SBA.K... | 11.1 | 1x |
| | 946-1195 | | GAK.945-1 | 3.1 | FSF | 10.16 | MK.250-1 | 9.1 | SBA.K... | 11.1 | 2x |
| | 1196-1445 | | GAK.945-1 | 3.1 | FSF | 10.16 | MK.500-1 | 9.1 | SBA.K... | 11.1 | 2x |
| | 1446-1475 | | GAK.945-1 | 3.1 | FSF | 10.16 | MK.750-1 | 9.1 | SBA.K... | 11.1 | 2x |
|  | 696-1475 | 696-2300 | E1 | 4.1 | | | | | SBS.K.PAD... | 11.7 | 1x |
|  | 696-1420 | 696-710 | KE SL | 9.3 | | | | | | | |
| | 696-1475 | 711-960 | KE SL | 9.3 | MK.250-1 | 9.1 | | | SBA.K... | 11.1 | 1x |
| | | 961-1210 | KE SL | 9.3 | MK.500-1 | 9.1 | | | SBA.K... | 11.1 | 1x |
| | | 1211-1460 | KE SL | 9.3 | MK.750-1 | 9.1 | | | SBA.K... | 11.1 | 1x |
| | | 1461-1710 | KE SL | 9.3 | MK.750-1 | 9.1 | MK.250-1 | 9.1 | SBA.K... | 11.1 | 2x |
| | | 1711-1960 | KE SL | 9.3 | MK.750-1 | 9.1 | MK.500-1 | 9.1 | SBA.K... | 11.1 | 2x |
| 1961-2210 | KE SL | 9.3 | MK.750-1 | 9.1 | MK.750-1 | 9.1 | SBA.K... | 11.1 | 2x | | |
| 2211-2300 | KE SL | 9.3 | MK.750-1 | 9.1 | MK.750-1 | 9.1 | SBA.K... | 11.1 | 3x | | |
|  | 696-1475 | 696-2300 | E1 | 4.1 | | | | | SBS.K.PAD... | 11.7 | 1x |
| | | | SL.C... | 7.1 | | | | | | | |
|  | 696-800 | 696-2300 | OS2.800 | 5.3 | | | | | | | |
| | 801-1025 | | OS2.1025-1 | 5.3 | | | | | SBA.K... | 11.1 | 1x |
| | 1026-1250 | | OS2.1250-1 | 5.3 | | | | | SBA.K... | 11.1 | 1x |
| | 1251-1475 | | OS2.1475-1 | 5.3 | | | | | SBA.K... | 11.1 | 1x |
|  | 696-1475 | 696-2300 | E2 | 4.2 | SL.C... | 7.1 | SC2.PAD... | 7.3 | | | |
|  | 696-1475 | 696-850 | MK.PA.250-1 | 9.7 | | | | | SBS.K.PAD... | 11.7 | 1x |
| | | 851-1075 | MK.PA.250-1 | 9.7 | M.250-1 | 9.2 | | | SBA.K... SBS.K.PAD... | 11.1 11.7 | 1x 1x |
| | | 1076-1525 | MK.PA.250-1 | 9.7 | M.500-1 | 9.2 | | | SBA.K... SBS.K.PAD... | 11.1 11.7 | 1x 1x |
| | | 1526-1800 | MK.PA.250-1 | 9.7 | MK.500-1 | 9.1 | M.500-1 | 9.2 | SBA.K... SBS.K.PAD... | 11.1 11.7 | 2x 1x |
| | | 1801-2300 | MK.PA.250-1 | 9.7 | MK.500-1 | 9.1 | M.750-1 | 9.2 | SBA.K... SBS.K.PAD... | 11.1 11.7 | 2x 1x |
|  | 696-1475 | 696-2300 | FL.C.PADM... | 6.1 | S.FL.C-W... | 6.9 | EL.CS... | 6.3 | SBS.K.PAD... | 11.7 | 1x |

Turn fitting system - central handle position

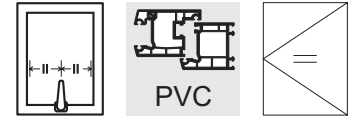

Basic equipment

Bottom window handle

activPilot Comfort PAD (operating sequence PADM)

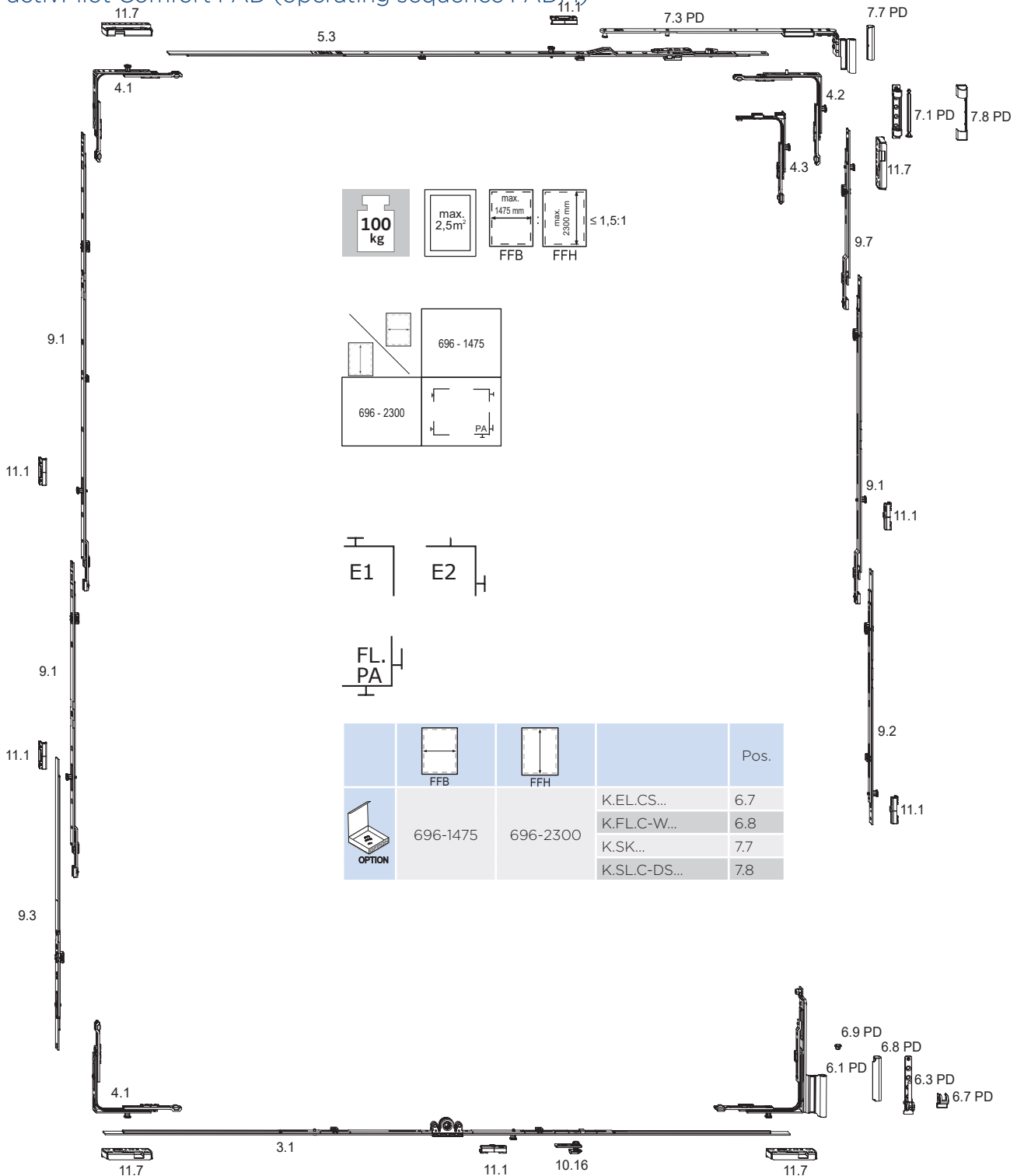

Note: You will find the components marked PD on the following pages. All other parts can be found in the activPilot Comfort PADK section.

The shown distance between locking points is 800 mm.







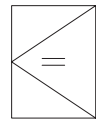
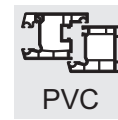
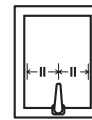



The locking distances must be agreed with the system provider.

Turn fitting system - central handle position

Basic equipment



2

| |  |  | | Pos. | | Pos. | | Pos. | | Pos. | |
|---|---|---|--------------|------|-------------|-------|------------|------|--------------------------|--------------|----------|
|  | 551-710 | 696-2300 | GAM.800 | 3.1 | | | | | | | |
| | 711-1050 | | GAM.1050-1 | 3.1 | FSF | 10.16 | | | SBA.K... | 11.1 | 1x |
| | 1051-1400 | | GAM.1400-1 | 3.1 | FSF | 10.16 | | | SBA.K... | 11.1 | 1x |
| | 1401-1475 | | GAM.1800-2 | 3.1 | FSF | 10.16 | | | SBA.K... | 11.1 | 2x |
|  | 551-1475 | 696-2300 | E1 | 4.1 | | | | | SBS.K.PAD... | 11.7 | 1x |
|  | 551-1420 | 696-710 | KE SL | 9.3 | | | | | | | |
| | 551-1475 | 711-960 | KE SL | 9.3 | MK.250-1 | 9.1 | | | SBA.K... | 11.1 | 1x |
| | | 961-1210 | KE SL | 9.3 | MK.500-1 | 9.1 | | | SBA.K... | 11.1 | 1x |
| | | 1211-1460 | KE SL | 9.3 | MK.750-1 | 9.1 | | | SBA.K... | 11.1 | 1x |
| | | 1461-1710 | KE SL | 9.3 | MK.750-1 | 9.1 | MK.250-1 | 9.1 | SBA.K... | 11.1 | 2x |
| | | 1711-1960 | KE SL | 9.3 | MK.750-1 | 9.1 | MK.500-1 | 9.1 | SBA.K... | 11.1 | 2x |
| | | 1961-2210 | KE SL | 9.3 | MK.750-1 | 9.1 | MK.750-1 | 9.1 | SBA.K... | 11.1 | 2x |
| 2211-2300 | KE SL | 9.3 | MK.750-1 | 9.1 | MK.750-1 | 9.1 | SBA.K... | 11.1 | 3x | | |
|  | 551-1475 | 696-2300 | E1 | 4.1 | | | | | SBS.K.PAD... | 11.7 | 1x |
|  | 551-600 | 696-2300 | OS1.600 | 5.3 | | | | | | | |
| | 601-800 | | OS2.800 | 5.3 | | | | | | | |
| | 801-1025 | | OS2.1025-1 | 5.3 | | | | | SBA.K... | 11.1 | 1x |
| | 1026-1250 | | OS2.1250-1 | 5.3 | | | | | SBA.K... | 11.1 | 1x |
| | 1251-1475 | | OS2.1475-1 | 5.3 | | | | | SBA.K... | 11.1 | 1x |
|  | 551-1475 | 696-2300 | E2 | 4.2 | S.L.C... | 7.1 | SC2.PAD... | 7.3 | | | |
|  | 551-1475 | 696-850 | MK.PA.250-1 | 9.7 | | | | | SBS.K.PAD... | 11.7 | 1x |
| | | 851-1075 | M.250-1 | 9.2 | MK.PA.250-1 | 9.7 | | | SBA.K... SBS.K.PAD... | 11.1 11.7 | 1x 1x |
| | | 1076-1525 | M.500-1 | 9.2 | MK.PA.250-1 | 9.7 | | | SBA.K... SBS.K.PAD... | 11.1 11.7 | 1x 1x |
| | | 1526-1800 | MK.500-1 | 9.1 | MK.PA.250-1 | 9.7 | M.500-1 | 9.2 | SBA.K... SBS.K.PAD... | 11.1 11.7 | 2x 1x |
| | | 1801-2300 | MK.PA.250-1 | 9.7 | MK.500-1 | 9.1 | M.750-1 | 9.2 | SBA.K... SBS.K.PAD... | 11.1 11.7 | 2x 1x |
|  | 696-1475 | 696-2300 | FL.C.PADM... | 6.1 | S.FL.C-W... | 6.9 | EL.CS... | 6.3 | SBS.K.PAD... | 11.7 | 1x |

Turn fitting system - constant handle position

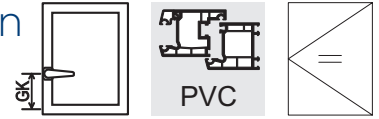





Basic equipment

low windows

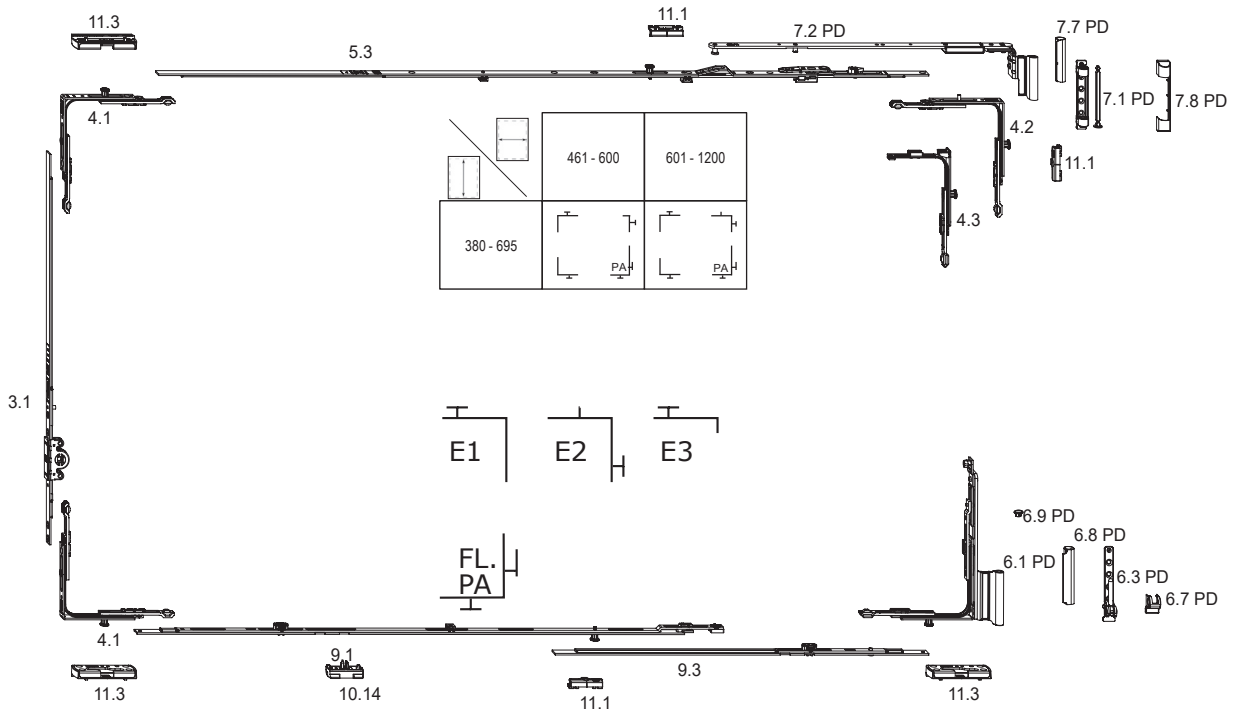
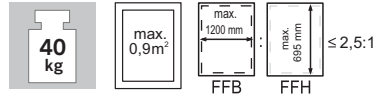
activPilot Comfort PAD

2



| |  |  | | Pos. |
|---|---|---|--------------|------|
|  | 461-1200 | 381-695 | K.EL.CS... | 6.7 |
| | | | K.FL.C-W... | 6.8 |
| | | | K.SK... | 7.7 |
| | | | K.SL.C-DS... | 7.8 |

Note: You will find the components marked PD on the following pages. All other parts can be found in the activPilot Comfort PADK section.







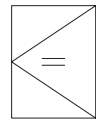
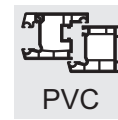
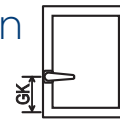

The shown distance between locking points is 800 mm.

The locking distances must be agreed with the system provider.

Turn fitting system - constant handle position

Basic equipment



| |  |  | | Pos. | | Pos. | | Pos. | | Pos. | |
|--|---|---|--------------|------|----------|-------|-------------|------|--------------|------|----|
|  | 461-920 | 381-460 | GAK.465 | 3.1 | | | GK = 210 | | | | |
| | 461-1200 | 461-695 | GAK.710 | 3.1 | | | GK = 210 | | | | |
|  <i>i</i> | 461-1200 | 381-695 | E1 | 4.1 | | | | | SBS...PAB... | 11.3 | 1x |
|  | 461-600 | 381-695 | OS1.600 | 5.3 | | | | | | | |
| | 601-800 | | OS2.800 | 5.3 | | | | | | | |
| | 801-1025 | | OS2.1025-1 | 5.3 | | | | | SBA.K... | 11.1 | 1x |
| | 1026-1200 | | OS2.1250-1 | 5.3 | | | | | SBA.K... | 11.1 | 1x |
|  | 461-600 | 381-695 | E3 | 4.3 | SL.C... | 7.1 | SC1.PAD... | 7.2 | SBA.K... | 11.1 | 1x |
| | 601-1200 | | E2 | 4.2 | SL.C... | 7.1 | SC2.PAD.... | 7.2 | SBA.K... | 11.1 | 1x |
|  | 461-1200 | 381-695 | FL.C.PADK... | 6.1 | EL.CS... | 6.3 | S.FL.C-W... | 6.9 | SBS...PAB... | 11.3 | 1x |
|  | 461-710 | 381-695 | KE SL | 9.3 | AL.M... | 10.14 | | | | | |
| | 711-960 | | KE SL | 9.3 | AL.M... | 10.14 | MK.250-1 | 9.1 | SBA.K... | 11.1 | 1x |
| | 961-1200 | | KE SL | 9.3 | AL.M... | 10.14 | MK.500-1 | 9.1 | SBA.K... | 11.1 | 1x |
|  <i>i</i> | 461-1200 | 381-695 | E1 | 4.1 | | | | | SBS...PAB... | 11.3 | 1x |

i marks a line with items that are always used, regardless of size

Turn fitting system - central handle position

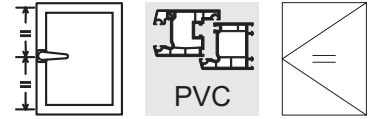

Basic equipment

low windows

activPilot Comfort PAD

2

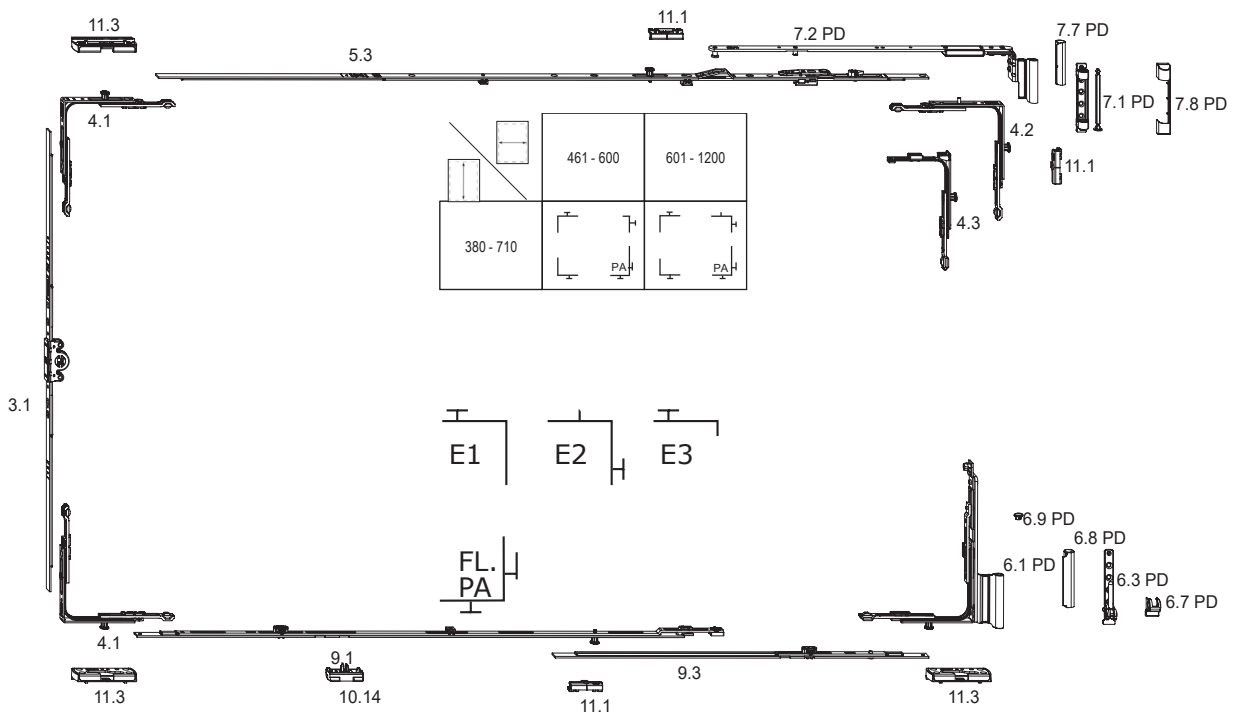
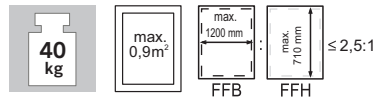

| | FFB | FFH | | Pos. |
|--|----------|---------|--------------|------|
| | 461-1200 | 381-710 | K.EL.CS... | 6.7 |
| | | | K.FL.C-W... | 6.8 |
| | | | K.SK... | 7.7 |
| | | | K.SL.C-DS... | 7.8 |

Note: You will find the components marked PD on the following pages. All other parts can be found in the activPilot Comfort PADK section.







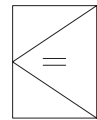
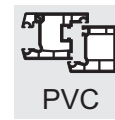
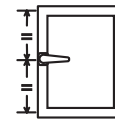

The shown distance between locking points is 800 mm.

The locking distances must be agreed with the system provider.

Turn fitting system - central handle position

Basic equipment



| |  |  | | Pos. | | Pos. | | Pos. | | Pos. | |
|--|---|---|--------------|------|----------|-------|-------------|------|--------------|------|----|
|  | 461-1020 | 381-510 | GAK.465 | 3.1 | | | | | | | |
| | 461-1200 | 511-710 | GAM.800 | 3.1 | | | | | | | |
|  i | 461-1200 | 381-710 | E1 | 4.1 | | | | | SBS...PAB... | 11.3 | 1x |
|  | 461-600 | 381-710 | OS1.600 | 5.3 | | | | | | | |
| | 601-800 | | OS2.800 | 5.3 | | | | | | | |
| | 801-1025 | | OS2.1025-1 | 5.3 | | | | | SBA.K... | 11.1 | 1x |
| | 1026-1200 | | OS2.1250-1 | 5.3 | | | | | SBA.K... | 11.1 | 1x |
|  | 461-600 | 381-710 | E3 | 4.3 | SL.C... | 7.1 | SC1.PAD... | 7.2 | SBA.K... | 11.1 | 1x |
| | 601-1200 | | E2 | 4.2 | SL.C... | 7.1 | SC2.PAD.... | 7.2 | SBA.K... | 11.1 | 1x |
|  | 461-1200 | 381-710 | FL.C.PADK... | 6.1 | EL.CS... | 6.3 | S.FL.C-W... | 6.9 | SBS...PAB... | 11.3 | 1x |
|  | 461-710 | 381-710 | KE SL | 9.3 | AL.M... | 10.14 | | | | | |
| | 711-960 | | KE SL | 9.3 | AL.M... | 10.14 | MK.250-1 | 9.1 | SBA.K... | 11.1 | 1x |
| | 961-1200 | | KE SL | 9.3 | AL.M... | 10.14 | MK.500-1 | 9.1 | SBA.K... | 11.1 | 1x |
|  i | 461-1200 | 381-710 | E1 | 4.1 | | | | | SBS...PAB... | 11.3 | 1x |

i marks a line with items that are always used, regardless of size

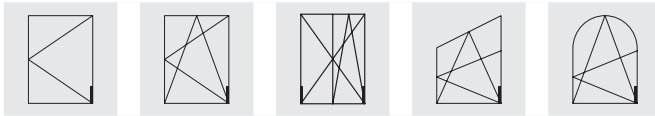
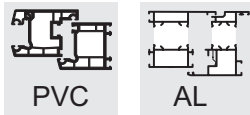

Corner hinges EL.CS

6

- Used in combination with overlap sash hinges FL.C or rebate sash hinges FL.C-W / FL.C.PA
- Large support area underneath the tilt axis
- For drilling instructions see group 15, installation drawings
- For sash weight see overview of articles
- Side adjustment ± 2 mm

Corner hinge cover K.EL.CS

- See separate product page

EL.CS

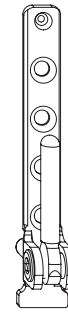

K.EL.CS



| Item designation | Item no. |  | Max. sash weight (kg) | VPA1 Pcs/type | VPA2 Pcs/type |
|------------------|----------|---|-----------------------|------------------|------------------|
| EL.CS.3-3-3 | 5064222 | 4 | 80 | 300 KK | 2400 EK |
| EL.CS.3-3-3.BR | 5064225 | 4 | 80 | 300 KK | 2400 EK |
| EL.CS.3-3-3.F9 | 5064224 | 4 | 80 | 300 KK | 2400 EK |
| EL.CS.3-3-3.WS | 5064223 | 4 | 80 | 300 KK | 2400 EK |
| EL.CS.6-3-3 | 5064226 | 4 | 100 | 300 KK | 2400 EK |
| EL.CS.6-3-3.BR | 5064229 | 4 | 100 | 300 KK | 2400 EK |
| EL.CS.6-3-3.F9 | 5064228 | 4 | 100 | 300 KK | 2400 EK |
| EL.CS.6-3-3.WS | 5064227 | 4 | 100 | 300 KK | 2400 EK |
| EL.CS.6-3-10 | 5064230 | 4 | 100 | 300 KK | 2400 EK |
| EL.CS.6-3-10.BR | 5064233 | 4 | 100 | 300 KK | 2400 EK |
| EL.CS.6-3-10.F9 | 5064232 | 4 | 100 | 300 KK | 2400 EK |
| EL.CS.6-3-10.WS | 5064231 | 4 | 100 | 300 KK | 2400 EK |
| EL.CS.6-3-22 | 5064234 | 4 | 130/150 | 300 KK | 2400 EK |
| EL.CS.6-3-22.BR | 5064237 | 4 | 130/150 | 300 KK | 2400 EK |
| EL.CS.6-3-22.F9 | 5064236 | 4 | 130/150 | 300 KK | 2400 EK |
| EL.CS.6-3-22.WS | 5064235 | 4 | 130/150 | 300 KK | 2400 EK |
| EL.CS.6-10-10.WS | 5064238 | 4 | 100 | 300 KK | 2400 EK |
| EL.CS.6-22-3 | 5064239 | 4 | 130/150 | 300 KK | 2400 EK |
| EL.CS.6-22-3.BR | 5064241 | 4 | 130/150 | 300 KK | 2400 EK |
| EL.CS.6-22-3.WS | 5064240 | 4 | 130/150 | 300 KK | 2400 EK |

WS = white; BR = brown, F9 = titanium coloured

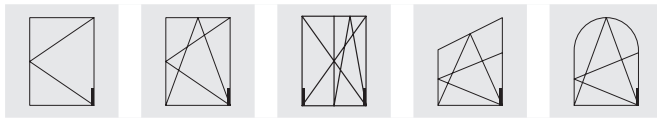
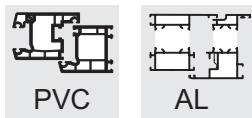

Corner hinges EL.CS-W

- Used in combination with rebate sash hinges FL.C-W / FL.C.PA
- Large support area underneath the tilt axis
- For drilling instructions see group 15, installation drawings
- Sash weight see Table of articles
- Side adjustment ± 2 mm
- With bolt support (max. parallel position of the bolt towards the corner hinge plate) avoids unintentional contact of the sash hinge roll and the corner hinge plate

- Recommendation for use: unfavourable sash formats, e. g.
- FFB > 1000 mm
- Sash rebate width: FFH > 1:1

Corner hinge cover K.EL.CS

- See separate product page

EL.CS-W

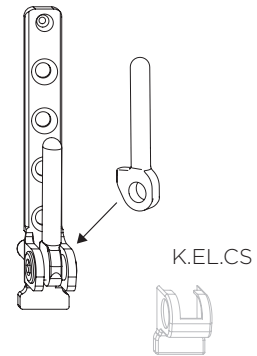

| Item designation | Item no. |  | Max. sash weight (kg) | VPA1 Pcs/type | VPA2 Pcs/type |
|--------------------|----------|---|-----------------------|------------------|------------------|
| EL.CS-W.6-3-3 | 5064244 | 4 | 100 | 300 KK | 2400 EK |
| EL.CS-W.6-3-3.F9 | 5064246 | 4 | 100 | 300 KK | 2400 EK |
| EL.CS-W.6-3-3.WS | 5064245 | 4 | 100 | 300 KK | 2400 EK |
| EL.CS-W.6-3-10 | 5064247 | 4 | 100 | 300 KK | 2400 EK |
| EL.CS-W.6-3-10.F9 | 5064249 | 4 | 100 | 300 KK | 2400 EK |
| EL.CS-W.6-3-10.WS | 5064248 | 4 | 100 | 300 KK | 2400 EK |
| EL.CS-W.6-3-22 | 5064250 | 4 | 130/150 | 300 KK | 2400 EK |
| EL.CS-W.6-3-22.F9 | 5064252 | 4 | 130/150 | 300 KK | 2400 EK |
| EL.CS-W.6-3-22.WS | 5064251 | 4 | 130/150 | 300 KK | 2400 EK |
| EL.CS-W.6-10-10.WS | 5064253 | 4 | 100 | 300 KK | 2400 EK |
| EL.CS-W.6-22-3 | 5064254 | 4 | 130/150 | 300 KK | 2400 EK |
| EL.CS-W.6-22-3.WS | 5064255 | 4 | 130/150 | 300 KK | 2400 EK |

WS = white; BR = brown, F9 = titanium coloured

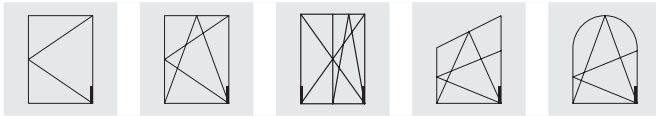
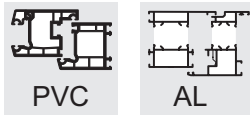

Corner hinge cap K.EL.CS

6

- Cover for narrow corner hinges EL.CS...
- For visual cover of the bottom area of the corner hinge
- Can be used left and right hand
- Available in different colours

EL.CS



K.EL.CS



| Item designation | Item no. | VPA1 Pcs/type | VPA2 Pcs/type | VPA3 Pcs/type |
|------------------|----------|------------------|------------------|------------------|
| K.EL.CS.BR | 5065117 | 100 BL | 1000 KK | 8000 EK |
| K.EL.CS.BZ-CN | 5065504 | 100 BL | 1000 KK | 8000 EK |
| K.EL.CS.BZ-RB | 5065508 | 100 BL | 1000 KK | 8000 EK |
| K.EL.CS.CW | 5065509 | 100 BL | 1000 KK | 8000 EK |
| K.EL.CS.F1 | 5065521 | 100 BL | 1000 KK | 8000 EK |
| K.EL.CS.F1-ELOX | 5065522 | 100 BL | 1000 KK | 8000 EK |
| K.EL.CS.F3 | 5065524 | 100 BL | 1000 KK | 8000 EK |
| K.EL.CS.F3-MG | 5065525 | 100 BL | 1000 KK | 8000 EK |
| K.EL.CS.F9 | 5065527 | 100 BL | 1000 KK | 8000 EK |
| K.EL.CS.LBR | 5065529 | 100 BL | 1000 KK | 8000 EK |
| K.EL.CS.LGR | 5065536 | 100 BL | 1000 KK | 8000 EK |
| K.EL.CS.PW | 5065537 | 100 BL | 1000 KK | 8000 EK |
| K.EL.CS.SW | 5065538 | 100 BL | 1000 KK | 8000 EK |
| K.EL.CS.UN77078 | 5065539 | 100 BL | 1000 KK | 8000 EK |
| K.EL.CS.WS | 5065119 | 100 BL | 1000 KK | 8000 EK |

AGR = anthracite grey, BR = brown, BZ-AM = bronze - antique brass, BZ-RB = bronze - red brown, BZ-CU = bronze coppery, CW = cream white, EV1 = anodised silver, F1 = silver colour, F1-elox = sim. to F1 anodised silver, F3 = gold colour, F3-MG = gold mat, F9 = titanium-coloured, LBR = clay brown, PW = pearl white, SG = silver grey, SGB = grey, SGR = dust grey, SL = silver look (galvanised), SW = deep black, WS = white

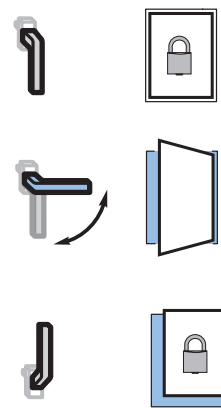
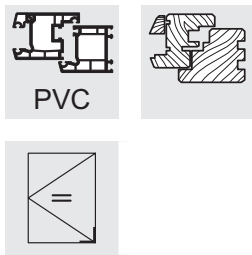

Sash hinges FL.C.PADK.20-13

- Height adjustment ± 3 mm
- Central fastening as standard
- Turn position is the factory default
- Overlapping system linkage without connecting plates
- In combination with corner hinges EL.CS, EL.CS-W, EL.HC, PA
- Parallel action possible via the control curve
- Operating sequence: locked position – turn position – parallel action

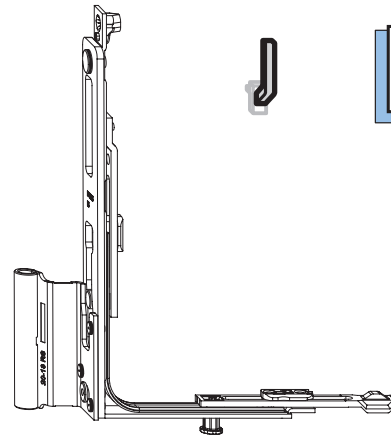



Sash hinge cover K.FL.C-W

- Available in different colours

Sash hinge plug S.FL.C-W

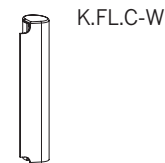
- Can be used left and right hand
- Dirt protection for height adjustment device
- Available in different colours



| Item designation | Item no. |  | Max. sash weight (kg) | Overlap | Groove centre position | VPA1 Pcs/type | VPA2 Pcs/type | VPA3 Pcs/type |
|-----------------------|----------|---|-----------------------|---------|------------------------|---------------|---------------|---------------|
| FL.C.PADK.20-13.LS | 5069170 | 4 | 100 | 20 | 13 | 20 KK | 160 EK | |
| FL.C.PADK.20-13.RS | 5069169 | 4 | 100 | 20 | 13 | 20 KK | 160 EK | |
| FL.C.PADK.20-13.LS.F9 | 5069174 | 4 | 100 | 20 | 13 | 20 KK | 160 EK | |
| FL.C.PADK.20-13.RS.F9 | 5069173 | 4 | 100 | 20 | 13 | 20 KK | 160 EK | |
| FL.C.PADK.20-13.LS.WS | 5069172 | 4 | 100 | 20 | 13 | 20 KK | 160 EK | |
| FL.C.PADK.20-13.RS.WS | 5069171 | 4 | 100 | 20 | 13 | 20 KK | 160 EK | |
| K.FL.C-W.LS.BR | 5065127 | | | | | 100 BL | 300 KK | 2400 EK |
| K.FL.C-W.RS.BR | 5065126 | | | | | 100 BL | 300 KK | 2400 EK |
| K.FL.C-W.LS.BZ-AM | 5065575 | | | | | 100 BL | 300 KK | 2400 EK |
| K.FL.C-W.RS.BZ-AM | 5065574 | | | | | 100 BL | 300 KK | 2400 EK |
| K.FL.C-W.LS.BZ-RB | 5065577 | | | | | 100 BL | 300 KK | 2400 EK |
| K.FL.C-W.RS.BZ-RB | 5065576 | | | | | 100 BL | 300 KK | 2400 EK |
| K.FL.C-W.LS.CW | 5065579 | | | | | 100 BL | 300 KK | 2400 EK |
| K.FL.C-W.RS.CW | 5065578 | | | | | 100 BL | 300 KK | 2400 EK |
| K.FL.C-W.LS.F1 | 5065581 | | | | | 100 BL | 300 KK | 2400 EK |
| K.FL.C-W.RS.F1 | 5065580 | | | | | 100 BL | 300 KK | 2400 EK |
| K.FL.C-W.LS.F1-ELOX | 5065583 | | | | | 100 BL | 300 KK | 2400 EK |
| K.FL.C-W.RS.F1-ELOX | 5065582 | | | | | 100 BL | 300 KK | 2400 EK |
| K.FL.C-W.LS.F3 | 5065603 | | | | | 100 BL | 300 KK | 2400 EK |
| K.FL.C-W.RS.F3 | 5065602 | | | | | 100 BL | 300 KK | 2400 EK |
| K.FL.C-W.LS.F9 | 5065605 | | | | | 100 BL | 300 KK | 2400 EK |
| K.FL.C-W.RS.F9 | 5065604 | | | | | 100 BL | 300 KK | 2400 EK |
| K.FL.C-W.LS.SW | 5065607 | | | | | 100 BL | 300 KK | 2400 EK |
| K.FL.C-W.RS.SW | 5065606 | | | | | 100 BL | 300 KK | 2400 EK |
| K.FL.C-W.LS.WS | 5065129 | | | | | 100 BL | 300 KK | 2400 EK |
| K.FL.C-W.RS.WS | 5065128 | | | | | 100 BL | 300 KK | 2400 EK |
| S.FL.C-W.BR | 5065613 | | | | | 500 BL | 3000 KK | 24000 EK |
| S.FL.C-W.F1 | 5065614 | | | | | 500 BL | 3000 KK | 24000 EK |
| S.FL.C-W.F9 | 5065615 | | | | | 500 BL | 3000 KK | 24000 EK |
| S.FL.C-W.WS | 5065616 | | | | | 500 BL | 3000 KK | 24000 EK |

RS = right, LS = left

WS = white, BR = brown, SL = silver, EV1 = anodised silver, F1 = silver colour, F3 = gold colour, BZ-RB = bronze red brown, F9 = titanium coloured, CW = cream white

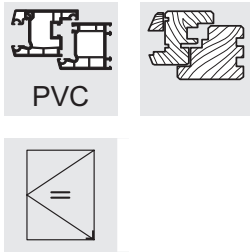

Sash hinges FL.C.PADM.20-13

- Height adjustment ± 3 mm
- Central position is the factory default
- In combination with corner hinges EL.CS / EL.CS-W / EL.HC.PA
- Parallel action possible via the control curve
- Operating sequence: locked position - parallel action - turn position

Sash hinge cover K.FL.C-W

- Available in different colours

Sash hinge plug S.FL.C-W

- Can be used left and right hand
- Dirt protection for height adjustment device
- Available in different colours

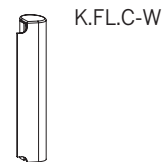
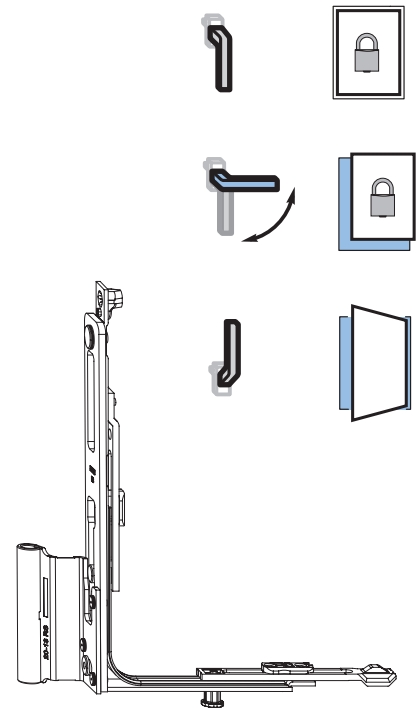

| Item designation | Item no. |  | Max. sash weight (kg) | Overlap | Groove centre position | VPA1 Pcs/type | VPA2 Pcs/type | VPA3 Pcs/type |
|-----------------------|----------|---|-----------------------|---------|------------------------|---------------|---------------|---------------|
| FL.C.PADM.20-13.LS | 5069188 | 4 | 100 | 20 | 13 | 20 KK | 160 EK | |
| FL.C.PADM.20-13.RS | 5069187 | 4 | 100 | 20 | 13 | 20 KK | 160 EK | |
| FL.C.PADM.20-13.LS.F9 | 5069200 | 4 | 100 | 20 | 13 | 20 KK | 160 EK | |
| FL.C.PADM.20-13.RS.F9 | 5069199 | 4 | 100 | 20 | 13 | 20 KK | 160 EK | |
| FL.C.PADM.20-13.LS.WS | 5069198 | 4 | 100 | 20 | 13 | 20 KK | 160 EK | |
| FL.C.PADM.20-13.RS.WS | 5069197 | 4 | 100 | 20 | 13 | 20 KK | 160 EK | |
| K.FL.C-W.LS.BR | 5065127 | | | | | 100 BL | 300 KK | 2400 EK |
| K.FL.C-W.RS.BR | 5065126 | | | | | 100 BL | 300 KK | 2400 EK |
| K.FL.C-W.LS.BZ-AM | 5065575 | | | | | 100 BL | 300 KK | 2400 EK |
| K.FL.C-W.RS.BZ-AM | 5065574 | | | | | 100 BL | 300 KK | 2400 EK |
| K.FL.C-W.LS.BZ-RB | 5065577 | | | | | 100 BL | 300 KK | 2400 EK |
| K.FL.C-W.RS.BZ-RB | 5065576 | | | | | 100 BL | 300 KK | 2400 EK |
| K.FL.C-W.LS.CW | 5065579 | | | | | 100 BL | 300 KK | 2400 EK |
| K.FL.C-W.RS.CW | 5065578 | | | | | 100 BL | 300 KK | 2400 EK |
| K.FL.C-W.LS.F1 | 5065581 | | | | | 100 BL | 300 KK | 2400 EK |
| K.FL.C-W.RS.F1 | 5065580 | | | | | 100 BL | 300 KK | 2400 EK |
| K.FL.C-W.LS.F1-ELOX | 5065583 | | | | | 100 BL | 300 KK | 2400 EK |
| K.FL.C-W.RS.F1-ELOX | 5065582 | | | | | 100 BL | 300 KK | 2400 EK |
| K.FL.C-W.LS.F3 | 5065603 | | | | | 100 BL | 300 KK | 2400 EK |
| K.FL.C-W.RS.F3 | 5065602 | | | | | 100 BL | 300 KK | 2400 EK |
| K.FL.C-W.LS.F9 | 5065605 | | | | | 100 BL | 300 KK | 2400 EK |
| K.FL.C-W.RS.F9 | 5065604 | | | | | 100 BL | 300 KK | 2400 EK |
| K.FL.C-W.LS.SW | 5065607 | | | | | 100 BL | 300 KK | 2400 EK |
| K.FL.C-W.RS.SW | 5065606 | | | | | 100 BL | 300 KK | 2400 EK |
| K.FL.C-W.LS.WS | 5065129 | | | | | 100 BL | 300 KK | 2400 EK |
| K.FL.C-W.RS.WS | 5065128 | | | | | 100 BL | 300 KK | 2400 EK |
| S.FL.C-W.BR | 5065613 | | | | | 500 BL | 3000 KK | 24000 EK |
| S.FL.C-W.F1 | 5065614 | | | | | 500 BL | 3000 KK | 24000 EK |
| S.FL.C-W.F9 | 5065615 | | | | | 500 BL | 3000 KK | 24000 EK |
| S.FL.C-W.WS | 5065616 | | | | | 500 BL | 3000 KK | 24000 EK |

RS = right, LS = left

WS = white, BR = brown, EV1 = anodised silver, CW = cream white, F9 = titanium coloured, BZ-CU = bronze copper, BZ-RB (F4)= bronze red brown, RAL9007 = colour according to RAL

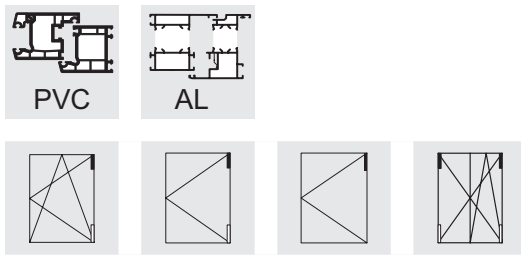

Shear hinge SL.C

- Rolled steel hinge
- Fixing screws are covered by the shear hinge insert.
- Integrated pin-securing device
- Remove shear pin by means of special pulling device
- A small free size of the frame is required.
- For drilling instructions see group 15, installation drawings

Shear hinge cover K.SL.C-DS

- See separate product page

Additional plate ZSP.SL. C

- Positioning and screwing above the shear hinge SL.C
- Improves the load transfer of the shear hinge to the frame by increasing the number of screws
- Enables higher traction values acc. to TBDK (e.g. in case of steelless systems)
- Available in different colours
- Covers K.SL.C... cannot be used in this combination.

SL.C

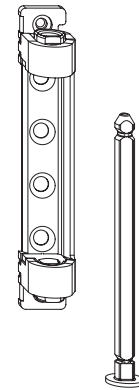

K.SL.C-DS



ZSP.SL.C



SL.C

| Item designation | Item no. |  | Max. sash weight (kg) | VPA1 Pcs/type | VPA2 Pcs/type | VPA3 Pcs/type |
|------------------|----------|---|-----------------------|------------------|------------------|------------------|
| SL.C.3-3 | 5081484 | 4 | 80 | 200 KK | 1600 EK | |
| SL.C.3-3.BR | 5081487 | 4 | 80 | 200 KK | 1600 EK | |
| SL.C.3-3.CW | 5081488 | 4 | 80 | 200 KK | 1600 EK | |
| SL.C.3-3.F9 | 5081486 | 4 | 80 | 200 KK | 1600 EK | |
| SL.C.3-3.WS | 5081485 | 4 | 80 | 200 KK | 1600 EK | |
| SL.C.3-6 | 5081489 | 4 | 130/150 | 200 KK | 1600 EK | |
| SL.C.3-6.BR | 5081492 | 4 | 130/150 | 200 KK | 1600 EK | |
| SL.C.3-6.CW | 5081493 | 4 | 130/150 | 200 KK | 1600 EK | |
| SL.C.3-6.F9 | 5081491 | 4 | 130/150 | 200 KK | 1600 EK | |
| SL.C.3-6.WS | 5081490 | 4 | 130/150 | 200 KK | 1600 EK | |
| ZSP.SL.C.WS | 5086827 | 1 | | 100 BL | 2000 KK | 16000 EK |
| ZSP.SL.C.F9 | 5086828 | 1 | | 100 BL | 2000 KK | 16000 EK |
| ZSP.SL.C.CW | 5086829 | 1 | | 100 BL | 2000 KK | 16000 EK |

WS = white, BR = brown, SL = silver, EV1 = anodised silver, F1 = silver colour, F3 = gold colour, BZ-RB = bronze red brown, F9 = titanium coloured, CW = cream white

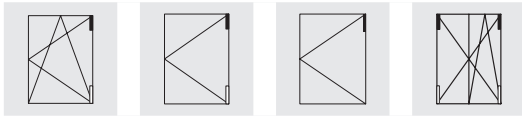
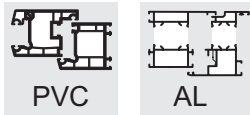

Caps

Shear hinge cover K.SL.C-DS

- Cover for shear hinge SL.C
- Can be used left and right hand

Shear hinge cap K.SK

- Can be used left and right hand
- Available in different colours



K.SL.C-DS



K.SK

7

| Item designation | Item no. | VPA1 Pcs/type | VPA2 Pcs/type | VPA3 Pcs/type |
|-------------------|----------|------------------|------------------|------------------|
| K.SL.C-DS.BR | 5081091 | 100 BL | 300 KK | 7200 EK |
| K.SL.C-DS.BZ-OPL | 5081099 | 100 BL | 300 KK | 7200 EK |
| K.SL.C-DS.BZ-RB | 5081098 | 100 BL | 300 KK | 7200 EK |
| K.SL.C-DS.CW | 5081096 | 100 BL | 300 KK | 7200 EK |
| K.SL.C-DS.F1 | 5081100 | 100 BL | 300 KK | 7200 EK |
| K.SL.C-DS.F1-ELOX | 5081101 | 100 BL | 300 KK | 7200 EK |
| K.SL.C-DS.F1-OPL | 5081102 | 100 BL | 300 KK | 7200 EK |
| K.SL.C-DS.F3 | 5081103 | 100 BL | 300 KK | 7200 EK |
| K.SL.C-DS.F3-MG | 5081104 | 100 BL | 300 KK | 7200 EK |
| K.SL.C-DS.F9 | 5081092 | 100 BL | 300 KK | 7200 EK |
| K.SL.C-DS.SW | 5081097 | 100 BL | 300 KK | 7200 EK |
| K.SL.C-DS.UN77078 | 5081105 | 100 BL | 300 KK | 7200 EK |
| K.SL.C-DS.WS | 5081090 | 100 BL | 300 KK | 7200 EK |
| K.SK.BR | 4927421 | 100 BL | 600 KK | 14400 EK |
| K.SK.BZ-CN | 5031480 | 100 BL | 300 KK | 2400 EK |
| K.SK.BZ-RB | 4933296 | 100 BL | 600 KK | 4800 EK |
| K.SK.CW | 4927572 | 100 BL | 600 KK | 4800 EK |
| K.SK.F1 | 4928484 | 100 BL | 600 KK | 4800 EK |
| K.SK.F1-ELOX. | 5021124 | 100 BL | 600 K3 | 4800 E3 |
| K.SK.F3 | 4995009 | 100 BL | 600 KK | 4800 EK |
| K.SK.F3 BA | 5034998 | 100 BL | 600 KK | 4800 EK |
| K.SK.F3-MG | 4987480 | 100 BL | 600 KK | 4800 EK |
| K.SK.F9 | 2845293 | 100 BL | 600 KK | 14400 EK |
| K.SK.LBR | 4939036 | 100 BL | 600 KK | 4800 EK |
| K.SK.SL.UN77078 | 4993489 | 100 BL | 600 KK | 4800 EK |
| K.SK.SW | 4939055 | 100 BL | 600 KK | 4800 EK |
| K.SK.WS | 2845285 | 100 BL | 600 KK | 14400 EK |

AGR = anthracite grey, BR = brown, BZ-AM = bronze - antique brass, BZ-RB = bronze - red brown, BZ-CU = bronze coppery, CW = cream white, EV1 = anodised silver, F1 = silver colour, F1-elox = sim. to F1 anodised silver, F3 = gold colour, F3-MG = gold mat, F9 = titanium-coloured, LBR = clay brown, PW = pearl white, SG = silver grey, SGB = grey, SGR = dust grey, SL = silver look (galvanised), SW = deep black, WS = white

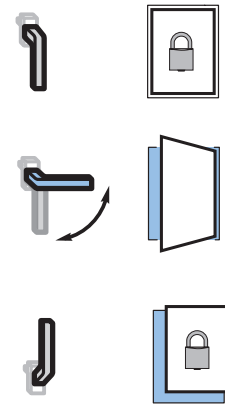
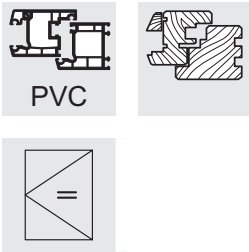

Shear SC ... 20-13

- Used in combination with shear hinge SL.C or SL.HC
- Only two shear sizes
- Adjustment for lifting and lowering the sash (+3.5/-2.0 mm)
- Tilt opening width approx. 135 to 140 mm (depending on profile)
- Use tilt limiter KBG.OS for sash rebate heights ≤ 600 mm
- Sash weight max. 130/150 kg (max. 100 kg for activPilot Comfort)
- Shear with tandem action
- After assembly the top rod and the shear are firmly attached to one another
- Integrated turn restriction via plastic sleeve in shear hinge
- Visible parts available in various colours
- Operating sequence: locked position – turn position – parallel action

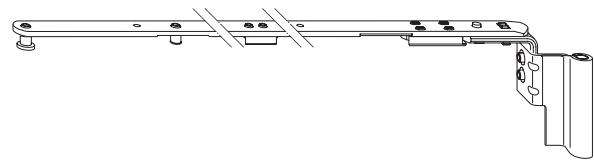

7

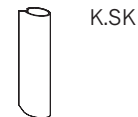

Shear hinge cap K.SK

- Can be used left and right hand

| Item designation | Item no. | Max. sash weight (kg) | Overlap | Groove centre position | VPA1 Pcs/type | VPA2 Pcs/type | VPA3 Pcs/type |
|------------------|----------|-----------------------|---------|------------------------|---------------|---------------|---------------|
| SC1.20-13.LS | 5062073 | 100 (130/150) | 20 | 13 | 10 BD | 60 KK | 480 EK |
| SC1.20-13.RS | 5062072 | 100 (130/150) | 20 | 13 | 10 BD | 60 KK | 480 EK |
| SC1.20-13.LS.BR | 5062079 | 100 (130/150) | 20 | 13 | 10 BD | 60 KK | 480 EK |
| SC1.20-13.RS.BR | 5062078 | 100 (130/150) | 20 | 13 | 10 BD | 60 KK | 480 EK |
| SC1.20-13.LS.CW | 5062081 | 100 (130/150) | 20 | 13 | 10 BD | 60 KK | 480 EK |
| SC1.20-13.RS.CW | 5062080 | 100 (130/150) | 20 | 13 | 10 BD | 60 KK | 480 EK |
| SC1.20-13.LS.F9 | 5062077 | 100 (130/150) | 20 | 13 | 10 BD | 60 KK | 480 EK |
| SC1.20-13.RS.F9 | 5062076 | 100 (130/150) | 20 | 13 | 10 BD | 60 KK | 480 EK |
| SC1.20-13.LS.WS | 5062075 | 100 (130/150) | 20 | 13 | 10 BD | 60 KK | 480 EK |
| SC1.20-13.RS.WS | 5062074 | 100 (130/150) | 20 | 13 | 10 BD | 60 KK | 480 EK |
| SC1.20-13.PLS | 5062083 | 100 (130/150) | 20 | 13 | 10 BD | 60 KK | 480 EK |
| SC1.20-13.PRS | 5062082 | 100 (130/150) | 20 | 13 | 10 BD | 60 KK | 480 EK |
| SC2.20-13.LS | 5062147 | 100 (130/150) | 20 | 13 | 10 BD | 80 GK | 960 EK |
| SC2.20-13.RS | 5062146 | 100 (130/150) | 20 | 13 | 10 BD | 80 GK | 960 EK |
| SC2.20-13.LS.BR | 5062153 | 100 (130/150) | 20 | 13 | 10 BD | 80 GK | 960 EK |
| SC2.20-13.RS.BR | 5062152 | 100 (130/150) | 20 | 13 | 10 BD | 80 GK | 960 EK |
| SC2.20-13.LS.CW | 5062155 | 100 (130/150) | 20 | 13 | 10 BD | 80 GK | 960 EK |
| SC2.20-13.RS.CW | 5062154 | 100 (130/150) | 20 | 13 | 10 BD | 80 GK | 960 EK |
| SC2.20-13.LS.F9 | 5062151 | 100 (130/150) | 20 | 13 | 10 BD | 80 GK | 960 EK |
| SC2.20-13.RS.F9 | 5062150 | 100 (130/150) | 20 | 13 | 10 BD | 80 GK | 960 EK |
| SC2.20-13.LS.WS | 5062149 | 100 (130/150) | 20 | 13 | 10 BD | 80 GK | 960 EK |
| SC2.20-13.RS.WS | 5062148 | 100 (130/150) | 20 | 13 | 10 BD | 80 GK | 960 EK |
| SC2.20-13.PLS | 5062158 | 100 (130/150) | 20 | 13 | 10 BD | 80 GK | 960 EK |
| SC2.20-13.PRS | 5062157 | 100 (130/150) | 20 | 13 | 10 BD | 80 GK | 960 EK |

RS = right, LS = left

WS = white, BR = brown, SL = silver, EV1 = anodised silver, F1 = silver colour, F3 = gold colour, BZ-RB = bronze red brown, F9 = titanium coloured, CW = cream white

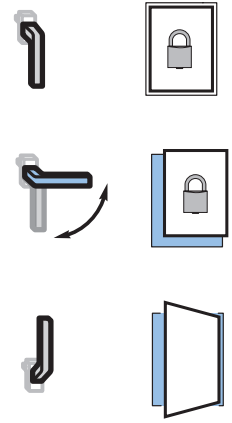
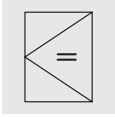
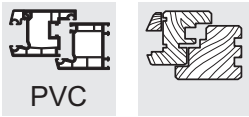

Shears SC ... PAD.20-13

7

- Suitable for top rods OS1/OS2
- For 20 mm overlap and 13 mm groove centre position
- Adjustment for lifting and lowering the sash (+3.5/-2.0 mm)
- Parallel opening approx. 6 mm
- After assembly the top rod and the shear are firmly attached to one another
- Integrated turn restriction via plastic sleeve in shear hinge
- Sash weight max. 100 kg
- With integrated control curve
- Operating sequence: locked position - parallel action - turn position

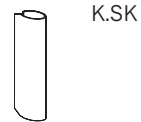
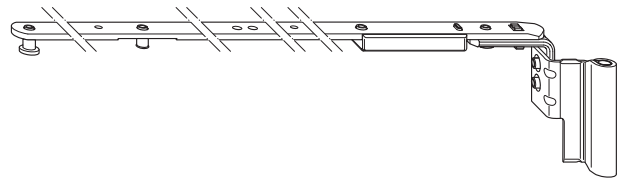

Shear hinge cap K.SK

- Can be used left and right hand

| Item designation | Item no. | Overlap | Groove centre position | VPA1 Pcs/type | VPA2 Pcs/type | VPA3 Pcs/type |
|---------------------|----------|---------|------------------------|---------------|---------------|---------------|
| SC1.PAD.20-13.LS.F9 | 5067584 | 20 | 13 | 10 BD | 60 KK | 1440 EK |
| SC1.PAD.20-13.RS.F9 | 5067583 | 20 | 13 | 10 BD | 60 KK | 1440 EK |
| SC1.PAD.20-13.LS.SL | 5067580 | 20 | 13 | 10 BD | 60 KK | 1440 EK |
| SC1.PAD.20-13.RS.SL | 5067579 | 20 | 13 | 10 BD | 60 KK | 1440 EK |
| SC1.PAD.20-13.LS.WS | 5067582 | 20 | 13 | 10 BD | 60 KK | 1440 EK |
| SC1.PAD.20-13.RS.WS | 5067581 | 20 | 13 | 10 BD | 60 KK | 1440 EK |
| SC2.PAD.20-13.LS.F9 | 5067590 | 20 | 13 | 10 BD | 80 GK | 960 EK |
| SC2.PAD.20-13.RS.F9 | 5067589 | 20 | 13 | 10 BD | 80 GK | 960 EK |
| SC2.PAD.20-13.LS.SL | 5067586 | 20 | 13 | 10 BD | 80 GK | 960 EK |
| SC2.PAD.20-13.RS.SL | 5067585 | 20 | 13 | 10 BD | 80 GK | 960 EK |
| SC2.PAD.20-13.LS.WS | 5067588 | 20 | 13 | 10 BD | 80 GK | 960 EK |
| SC2.PAD.20-13.RS.WS | 5067587 | 20 | 13 | 10 BD | 80 GK | 960 EK |

RS = right, LS = left
 WS = white, BR = brown, SL = silver, F1 = silver coloured, F3 = gold coloured, F9 = titanium coloured

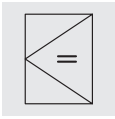
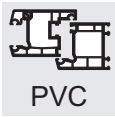

Frame parts

- Profile dependent see Group 11 (PADK), Frame Parts

Security Keep SBS....PAB

- Circumferential installation situation
- Number of screws: 4
- Operating sequence: locked position – turn position – parallel action

Keep SBAK

- Can be used left and right hand

Spacer FT WSK

- Can be used left and right hand

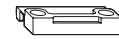
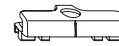
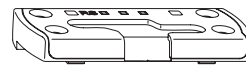

Frame parts for drive side handle position

Operating sequence: locked position – turn position – parallel action

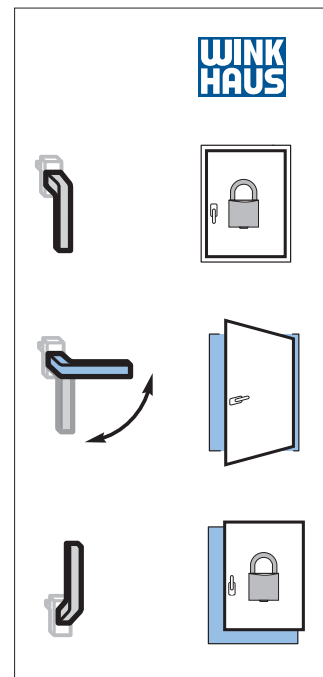

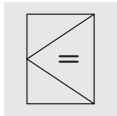
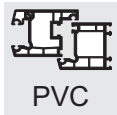

Frame parts

- Profile dependent see Group 11 (PADK), Frame Parts
- Security keep SBS.K.PAD
- Circumferential installation situation
- Available for mounting left and right hand
- Number of screws: 4
- The keep is marked "M" on the web for identification.
- Operating sequence: locked position – parallel action – turn position

Keep SBAK

- Can be used left and right hand

Spacer FT WSK

- Can be used left and right hand

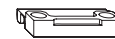
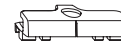
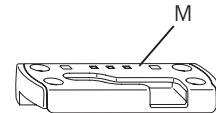

Frame parts for bottom handle position

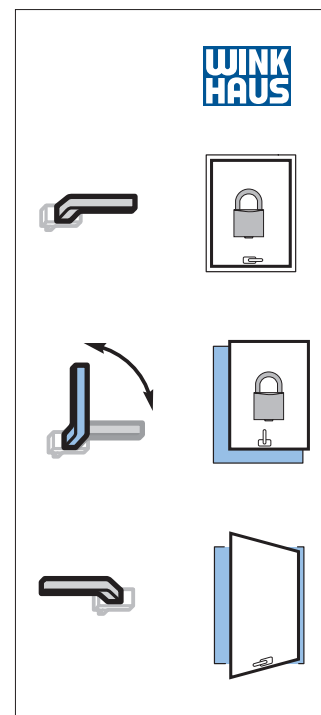

13 Installation Instructions

287 - 309

13.1 Notes on these assembly instructions

13.2 Shortening the fittings

13.3 Assembly of the turn fitting system

13.6 Function test / Operation

13

13.1

13.2

13.3

13.6

Notes on these assembly instructions

Prerequisites:

The mounting instructions are designed for mounting Winkhaus activPilot fittings for windows and glazed doors only. Fittings are designed for the following sash rebate sizes and sash weights:

- Min. sash rebate width 460 mm
- Max. sash rebate width 1475 mm
- Min. sash rebate height 695 mm
- Max. sash rebate height 2300 mm
- Max. sash size 2.5 m²
- Max. sash weight 100 kg
- Aspect FFB/FFH ≤ 1.5:1
- Airgap 12 mm
- Groove centre position 13 mm
- Frame rebate depth min. 29 mm
- Approved for centre gasket systems and rebate sealing systems with rain guard.



Note: In order to ascertain the permissible sash sizes and sash weights, please refer to the diagrams in the chapter "General Product Information".

Persons involved in mounting fittings must have read and understood this fitting guide. Observe production liability information for all work with fittings. Manufacturer will accept no liability in cases of failure to comply with this guide, deployment of insufficiently qualified staff and unauthorised alterations.

The respective overall fitting must be selected from the original fitting components range. Winkhaus accepts no liability if non-original or unauthorised system accessory parts are used.



Please note! Winkhaus does not provide fastening screws for fitting. Always use fastening screws suitable for the window type and window dimensions.



Note: activPilot Comfort fittings are not suitable for use in panic doors! They are not recommended for passage doors.

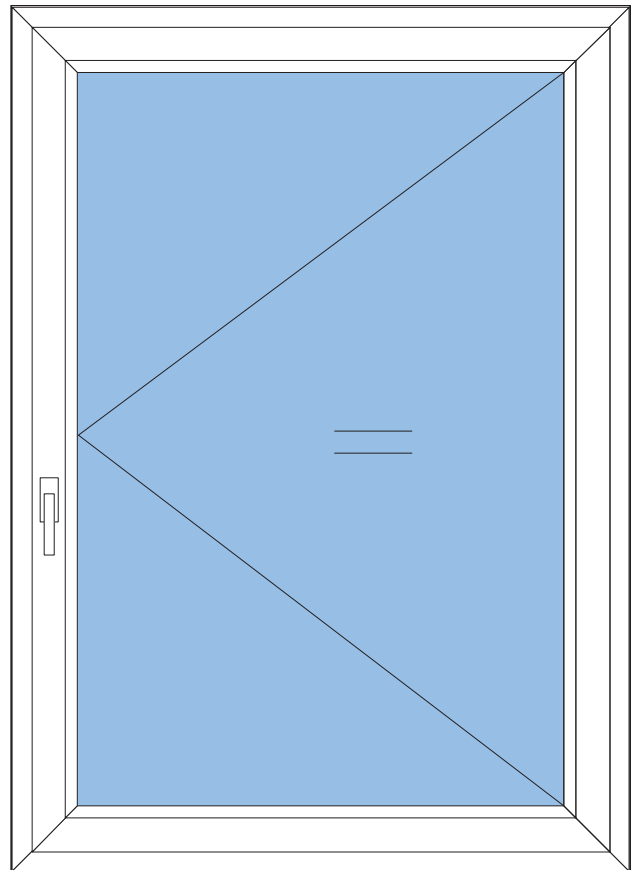

Standard profile dimensions

See figure: Profile cross-section

The fitting can be used on PVC-U windows with a standard eurogroove.



activPilot Comfort fittings are suitable for centre gasket systems or rebate sealing systems in combination with rain guards.

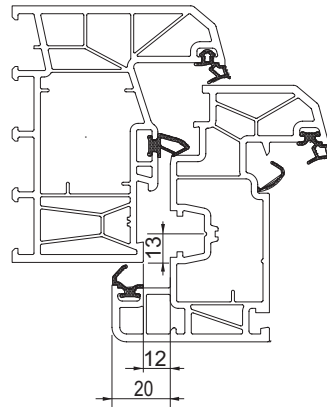

Profile cross-section

Shortening the fittings

A detailed description on shortening of fittings is available here. This description will be referred to in these assembly instructions.

See figure: Fittings prior to punching

- Always insert the face plate (1) and drive rod (2) perpendicularly from the top with the face plate (1) pointing to the pressure cylinder.

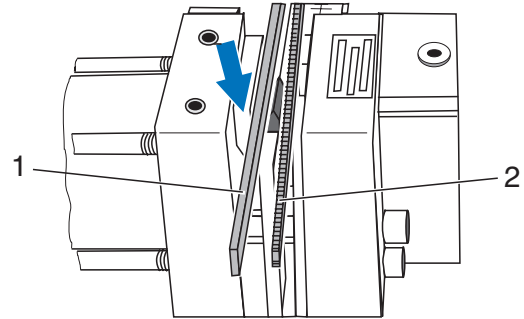

Fittings prior to punching

See figure: Fittings after punching

- After punching, always remove the face plate (1) and drive rod (2) perpendicularly in an upwards direction.

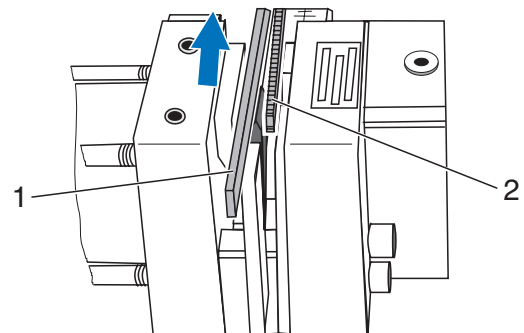

Fittings after punching

See figure: Cleaning the supporting surfaces

- Keep the supporting surfaces (3 and 4) clean.

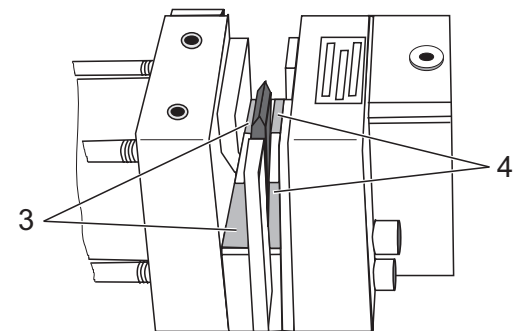

Cleaning the supporting surfaces

Shorten the drive rod GAM (central handle position)

See figure: Marking GAM

- Set measuring value FFH on the measuring device to the GAM mark.



Please note! If the GAM scale is displaced by one submarking, this corresponds to a longitudinal shift of 2 mm.

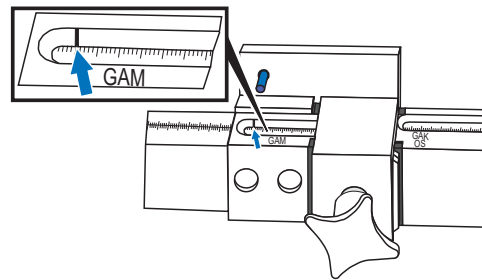

Marking GAM

See figure: Position for shortening drive rod

- Position the GAM drive rod at the scale; slot drill hole (2) onto bolt (1).
- Turn the GAM drive rod around, and slot the drill hole (3) onto the bolt (1), then trim the other side.
- Shorten the drive rod using the fitting punch.

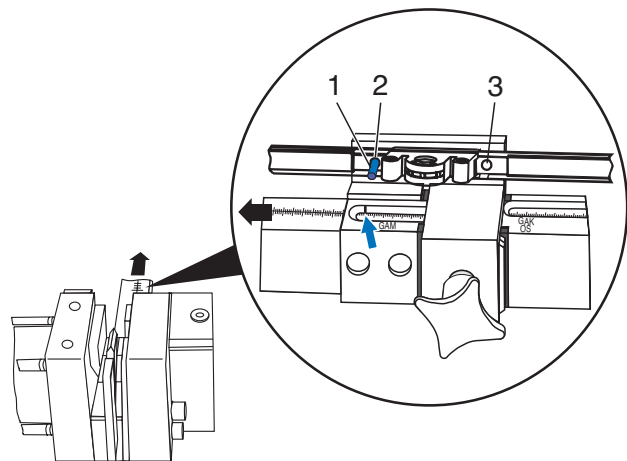

Position for shortening drive rod

Shorten the GAK / GASK drive rod (constant handle position) and top rod OS



Note: The double-sash drive rod must be trimmed before delivery.

See figure: Markings GAK and OS

- Set the measuring value FFH (GAK/GASK) or FFB (OS) on the measuring device to the GAK/OS mark.



Markings GAK and OS

See figure: Position for shortening drive rod and/or top rod

- Cutting the top rod OS...
 - Position the drive rod GAK/GASK (fixed handle position) (1) or the top rod OS (1) at the bolt (2).
 - Shorten the drive rod (1) or the top rod (1).

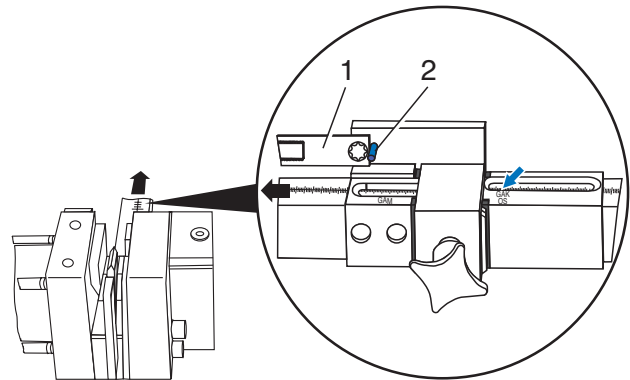

Position for shortening drive rod and/or top rod

Only applies to top rod OS1.600 (OS1.PA.600/OS.XL):

See figure: Position for shortening top rod

- Position the top rod (1) with square holes at bolt (2). At the same time press the offset (see arrow) against the bolt (2).
- Shorten the top rod (1).

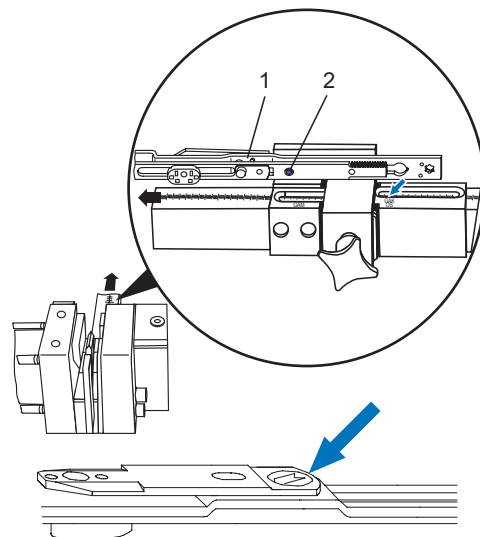

Position for shortening top rod

Mounting of fittings on sash

Rectangular turn window

Prepare the window for fitting. Then proceed as follows:

i Note: The following figures refer to a window for right hand use. When fitting a window for left-hand use, the figures will be mirror-inverted.

The following also applies:

- When viewing the window from the inside, the symbol is depicted as a full line.
- When viewing the window from the outside, the symbol is depicted as a dotted line.

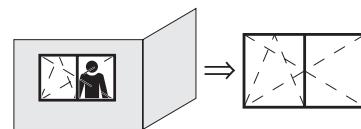
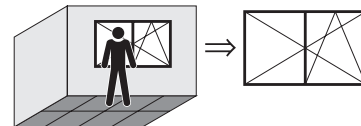

Determine the handle height:

Handle height for drive rod GAM

See figure: Sash rebate height FFH with central handle height GM

If you use a GAM drive rod ... (central handle position), the dimension GM is half the sash rebate height FFH.

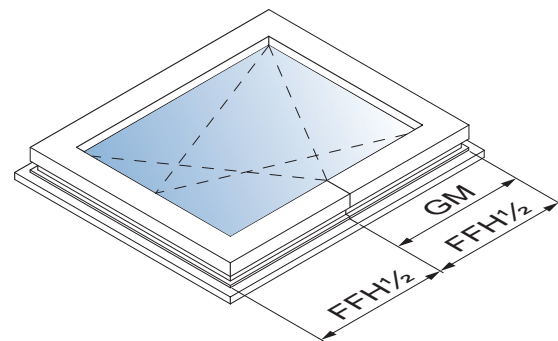

Sash rebate height FFH with central handle height GM

Handle height for drive rod GAK

See figure: Sash rebate height FFH with constant handle position GK

If you use a GAK drive rod ... (constant handle position), dimension GK changes to reflect the sash rebate height FFH. The exact dimensions are specified in the following table.

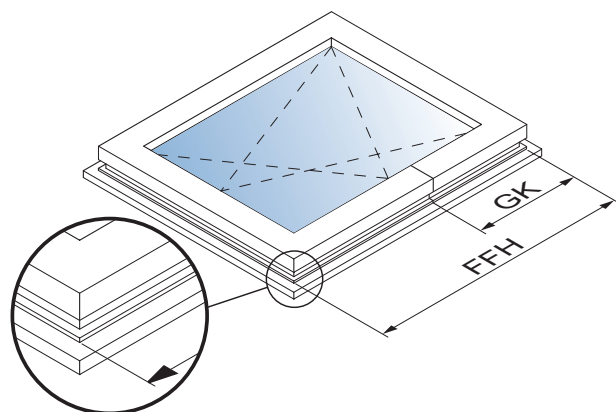

Sash rebate height FFH with constant handle position GK

See figure: Synoptical table: sash rebate height (FFH) / handle position (GK)

The table on the right gives a survey on the handle height (GK) of GAK with regard to the sash rebate height (FFH).

| FFH | GK |
|-------------|------------|
| 230 – 324 | GK = 114 * |
| 325 – 420 | GK = 114 * |
| 421 – 460 | GK = 210 |
| 461 – 700 | GK = 210 |
| 701 – 850 | GK = 260 |
| 851 – 1100 | GK = 375 |
| 1101 – 1325 | GK = 550 |
| 1326 – 1525 | GK = 550 |
| 1526 – 1775 | GK = 550 |
| 1776 – 2000 | GK = 1050 |
| 2001 – 2225 | GK = 1050 |

Synoptical table: sash rebate height (FFH) / handle position (GK)
 * Requires the use of E3 corner drive

See figure: Scale drawing “Gear lock”

- Drill holes for gear case (ø 12 mm) as per scale drawing.

Mill the gear housing from the rebate side.

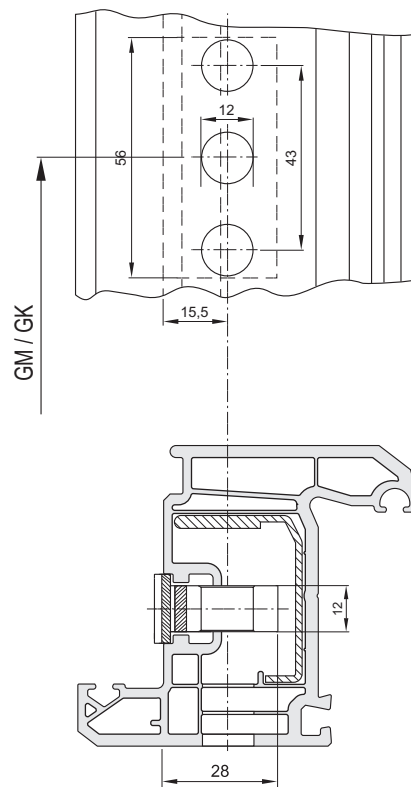

Scale drawing “Gear lock”

See figure: Corner drive E1

- Mounting of interlocking rods:
 - Fit the corner drive (2) into the fitting groove at the top of the sash so that the octagonal bolt is on the top side.
 - Fit the corner drive (1) into the fitting groove at the bottom of the sash so that the octagonal bolt is on the underside.
 - Fix both corner drives (1, 2) on the drive side with a single screw each.
 - Measure the sash rebate height (FFH).

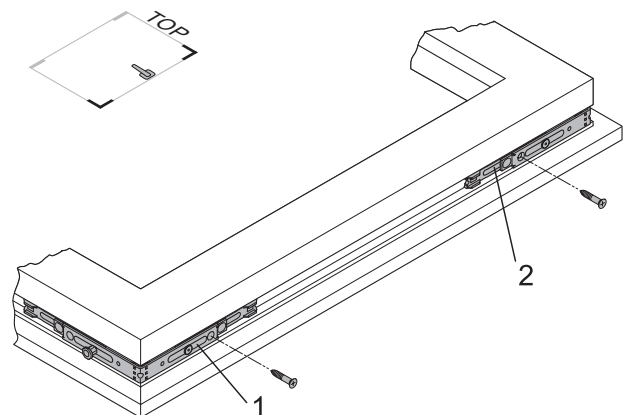

Corner drive E1

13.3

See figure: Drive rod GAM/GAK

- Cut the drive rod according to the instructions.
- Mount the drive rod:
 - Abut the drive rod (2) flush against the corner drive (3).
 - Allow the teeth on the drive rod to click into position on the gear rack on the corner drive.
 - Clip the drive rod into the corner drive (1) in the same way.
 - Press the drive rod into the eurogroove.
 - Screw the drive rod from the bottom up.



Note: Please make sure that the installation position of the drive rod is correct!

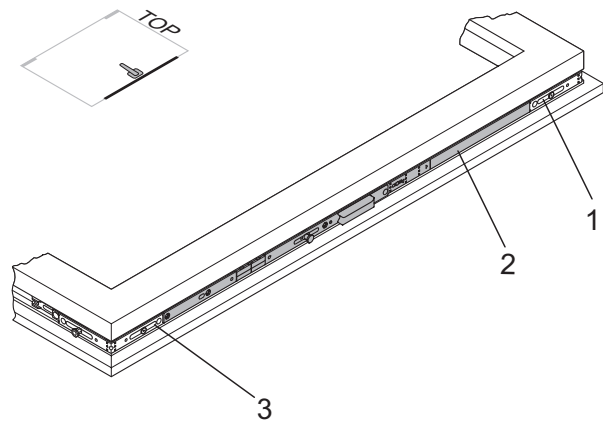

Drive rod GAM/GAK

See figure: Corner drive E2

- Fit the corner drive (1) into the fitting groove at the top of the sash so that the octagonal bolt is on the hinge side.
- Fasten the corner drive on the sash using a screw (2).
- Measure the sash rebate width (FFB).



Note: When the top rod OS1.PA.600 is used, replace the E2 corner drive by E3 corner drive.

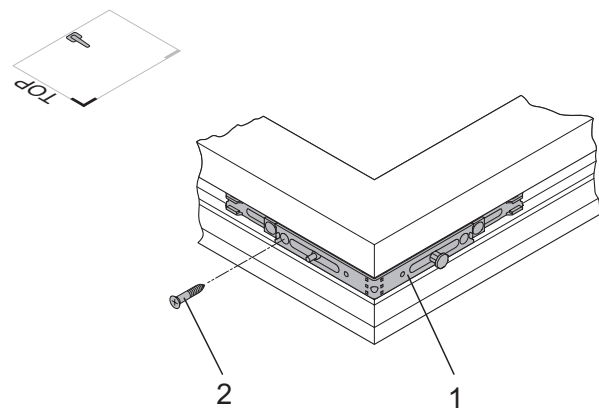

Corner drive E2

- Cut the top rod (see chapter 'Shortening the fittings').



Note: For FFH < approx. 600 mm (depending on profile), place tilt limiter on top rod OS... (2).

See figure: Top rod OS

- Cut the top rod (see chapter 'Shortening the fittings').
- Insert the top rod and screw into position.
 - Fit the top rod flush against the corner drive (1).
 - Allow the gear teeth to click into place on the rack in the corner drive.
 - Clip the top rod into the corner drive (3) in the same way.
 - Press the top rod into the fitting groove.
 - Screw the top rod from the hinge side to the drive side.

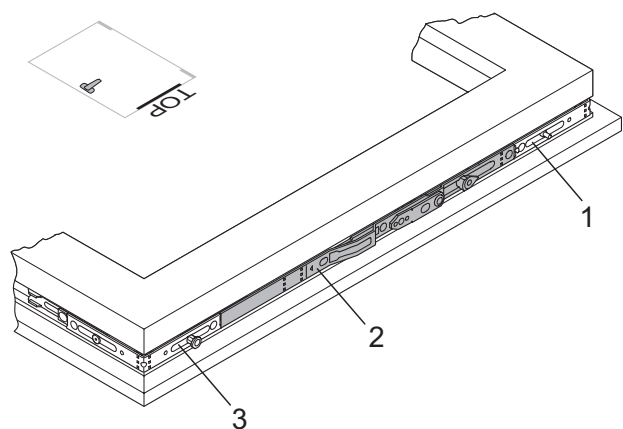

Top rod OS

See figure: Shears

- Mounting the shear:
 - Swivel out the hold-up shore (2) (see arrow).
 - Clip shear into the top rod (3) using mushroom bolt (4).
 - Press the shear bolt (5) into the spring on the hold-up shore.
 - Swivel the hold-up shore and shear to home position.
 - Press the shear onto the bolt (1).

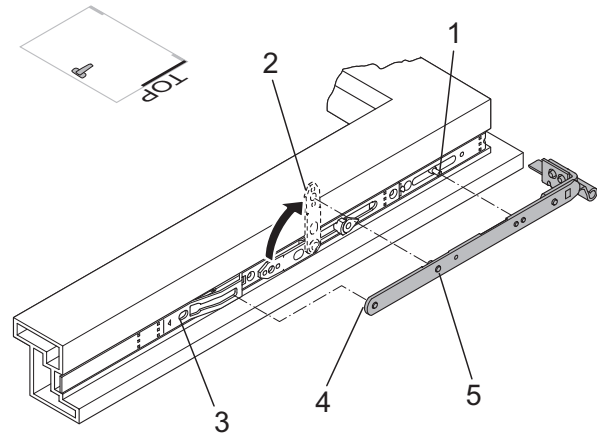

Shears



Please note! Risk of injury. The sash can fall out and cause injuries if the shear and top rod are not securely fastened.



Note: For a sash rebate height (FFH) and/or sash rebate width (FFB) of approx 800 mm (depending on the profile) an interlocking rod should also be fitted hinge-side and/or horizontally at the bottom / top.

See figure: Interlocking rod MK.PA

- Fit the interlocking rod (1) flush against the corner drive (2).
- Click the interlocking rod gears into the teeth of the corner drive.
- Press the interlocking rod into the fitting groove.
- Screw the interlocking rod from the top down.
- Tighten the screw (3) fully to release the central fastening.

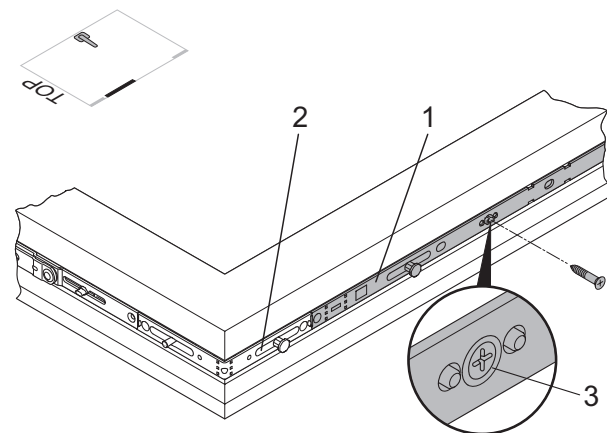

Interlocking rod MK.PA



Please note! Damage to fittings. If the central fastening is not released, the locking device cannot be actuated. Use of force will lead to torsion of the fittings. Always insert the screw fully up to the stop.

13.3

See figure: Corner drive E1

- Screw the corner drive (1) in place.

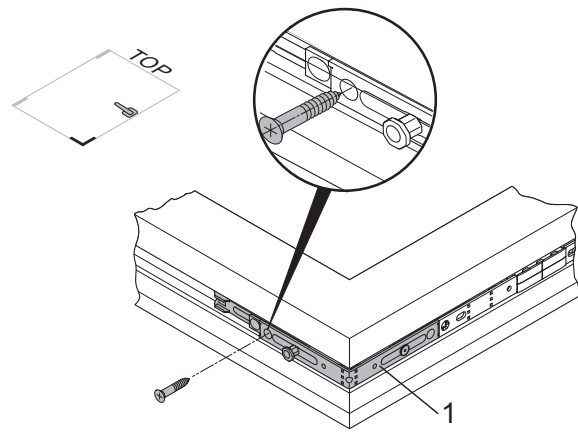

Corner drive E1

See figure: Support plate AL.M.F12

- Mount the coupling element, the interlocking rod and the support plate on the underside:
 - Fix the interlocking rod to the corner drive, depending on the sash rebate width.
 - Cut the coupling element to the required dimension.
 - Abut the coupling element against the sash hinge with the side to be cut pointing towards the drive side.
 - Click the coupling element gears into the teeth of the sash hinge.
 - Tighten the screw (3) fully to release the central fastening.
 - Fix the support plate on the coupling element with a screw.

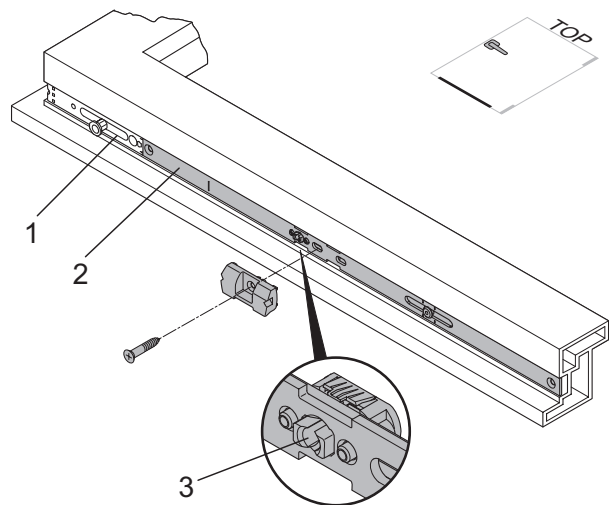

Support plate AL.M.F12

See figure: Fail safe device FSF

- Mount the fail safe device:
 - Insert the fail safe device on the hole pattern of the drive rod and fix with a screw.
 - If required, turn the head by 90° (depends on profile).
 - Mounting a frame part is not necessary.

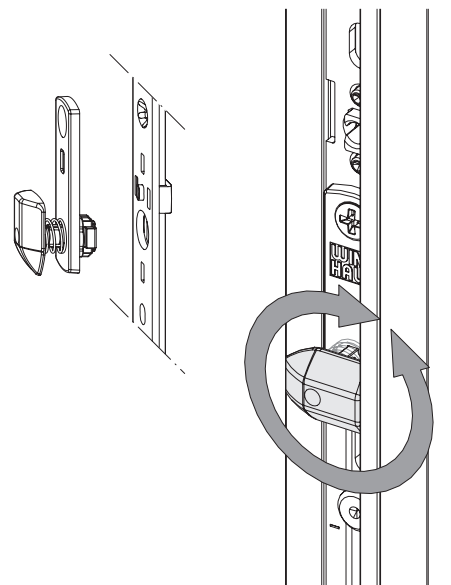

Fail safe device FSF

Important to know:

- The component's delivery state is neutral with regard to the DIN direction!
- After installation the tip of the pressure piece must be directed towards the frame!
- For airgaps smaller or larger than 12 mm an adjustment is possible by turning the plastic part to the left or to the right!



Please note! Check if all screws are fixed into place on the fitting parts.

Mounting of fittings on the window frame

For parallel action rectangular turn window



Note: Do not fit the shear and corner hinges until after fitting the keeps.

See figure: Holes for corner and shear hinges

- Drill \varnothing 2.5 to 3 mm pilot holes for shear and corner hinges and drill \varnothing 6 mm pilot holes for spindle plug positions.
- Use the template (1) to drill holes for corner hinge (3) and shear hinge (2). Distance between drill holes for shear and corner hinges is the same.



Note: Do not fit the shear and corner hinges until after fitting the keeps.

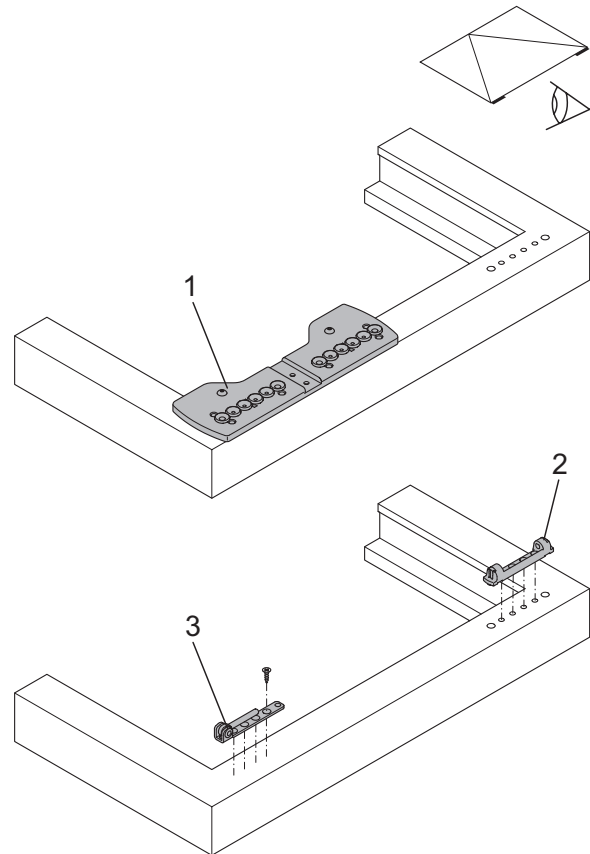

Holes for corner and shear hinges

Positions of keeps (basic equipment)

For parallel action rectangular turn window

The following figures show the keep position options. The number of keeps depends on the size of the window.



Note: The dimensions shown in the figures refer to the frame rebate edge to keep profile edge or frame centre to the keep!

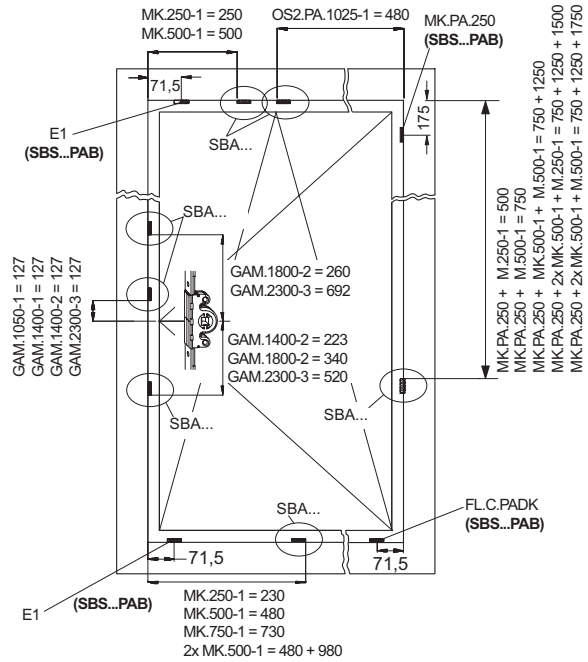

Keep positions DK "central handle position"

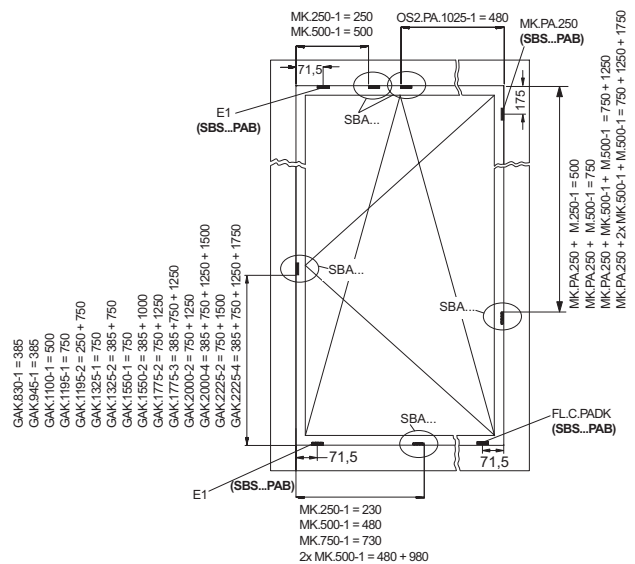

Keep positions DK "constant handle position"

Positions of keeps (RC2)

The following figures show the keep position options. The number of keeps depends on the size of the window.



Note: The keeps are security keeps SBS...PAD. The measurements refer to the "centre" of the keep.

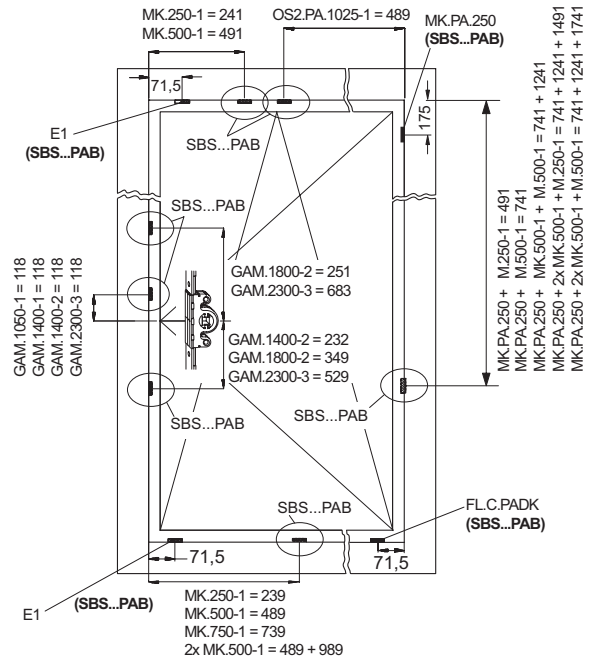

Keep positions DK "central handle position"

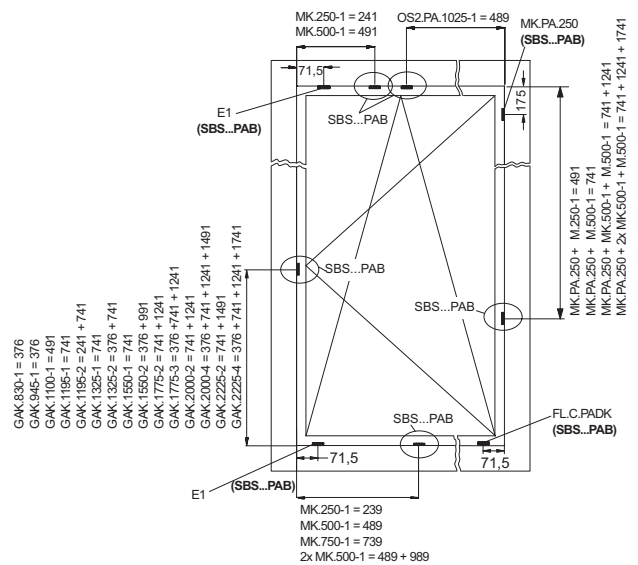

Keep positions DK "constant handle position"

Fitting the keeps

Handling of mounting jigs is explained by reference to the L.E.N.K. 710-1100 mounting jig in the following. Other mounting jigs are used in the same way. To position keeps, place the mounting jig on the frame rebate edge.

Labelling of mounting jigs



Horizontal attachment = red element (for top rod and interlocking rod)



Vertical attachment = yellow element (for drive rods and interlocking rods)



Vertical / horizontal attachment = blue element (for corner drives)



= Keep run-in

Keep SBS...PA, drive side bottom corner drive for E1

See figure: SBS..PA

- Use a PADK jig for the keeps needed for the parallel position activPilot Comfort.
- Position the mounting jig with the red element in the corner.
- Position the SBS...PA keep on the red element marked E1.PA, FL...PA, E1.

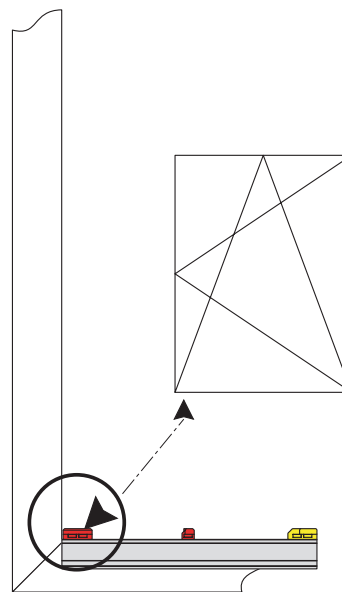

SBS..PA

Keep SBS...PA drive side, top corner drive for E1

See figure: Keep SBS...PA

- Use a PADK jig for the keeps needed for the parallel position activPilot Comfort.
- Align the mounting jig with the red element in the corner.
- Position the SBS...PA keep on the red element marked E1.PA, FL...PA, E1.

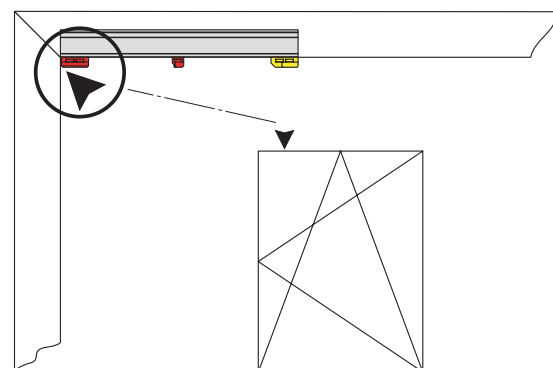

Keep SBS...PA

Keep SBS...PAB top hinge side for MK.PA.250

See figure: SBS...PAB top, horizontal

- Use a PADK jig for the keeps needed for the parallel position activPilot Comfort.
- Position the mounting jig with the yellow element in the upper corner.
- Position the keep SBS...PA.. on the red element marked MK.PA.250.

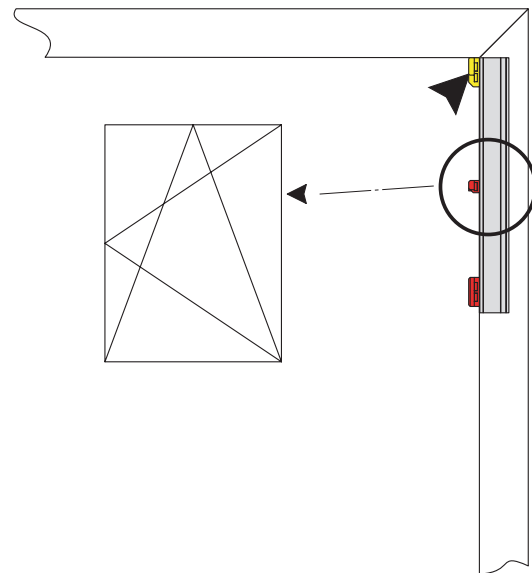

SBS...PAB top, horizontal

Keep SBS...PAB for sash hinge FL...PA bottom hinge side

See figure: Keep SBS...PAB

- Use a PADK jig for the keeps needed for the parallel position activPilot Comfort.
- Position the mounting jig with the red element in the corner.
- Position the SBS...PAB keep on the red element marked E1.PA, FL...PA, E1.

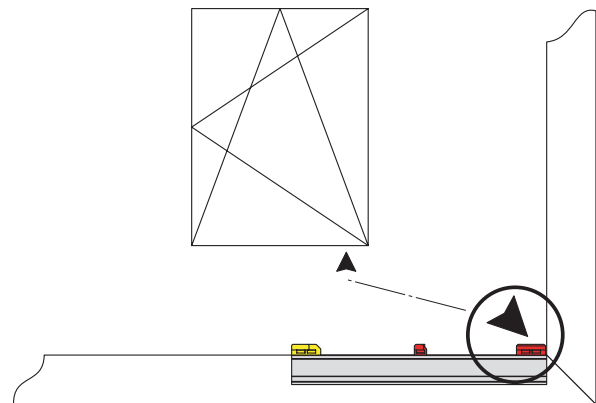

Keep SBS...PAB

Keeps SBA... for vertical GAK

- Align the mounting jig with the yellow element in the bottom corner.
- Place the SBA. ... keeps on the yellow and blue elements marked "GAK. ...".

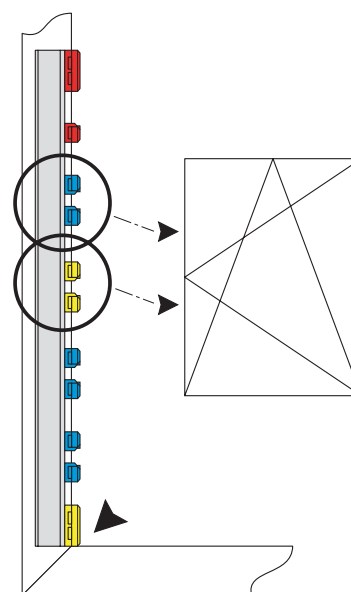

SBA... for vertical GAK

13.3

Keeps for GAM

- Attach the corresponding mounting jig labelled “top” or “bottom”.
- Fit keeps in line with the labelling on the mounting template.

There are three telescopic jigs depending on the window height:

- LE.N.T. 0710-1050 for drive rod GAM 1050-1
- LE.N.T. 1051-1800 for drive rod GAM 1400-1/2 / 1800-2
- LE.N.T. 1801-2300 for drive rod GAM 2300-3

i Note: The labelling on the drive rod must match the labelling on the yellow templates.

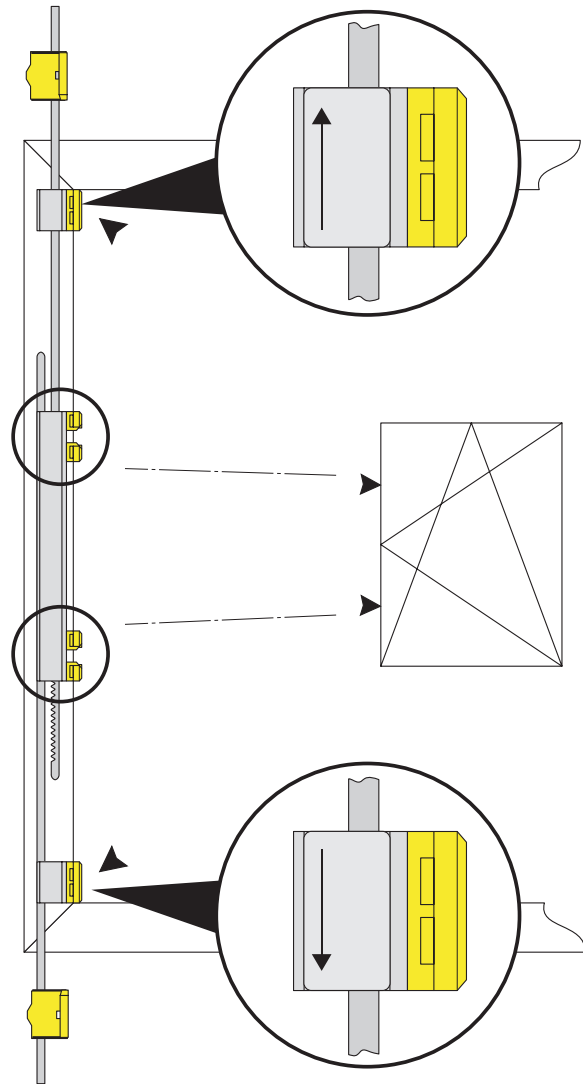

Keeps for GAM

Keep for interlocking rod M or MK hinge side in shear hinge area

See figure: Keeps hinge side

- Align the mounting jig with the yellow element in the top corner.
- Position the keep for interlocking rod on the yellow element.

i Note: The labelling on the interlocking rod must match the labelling on the yellow templates. The interlocking rod MK is labelled e.g. "MK.750-1".

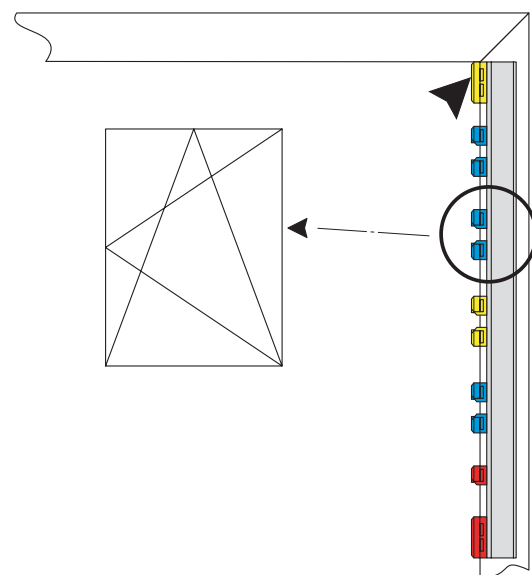

Keeps hinge side

Interlocking Rod M..., bottom, horizontal

See figure: M bottom horizontal

- Align the mounting jig with the red element in the lower corner.
- Position the keep on the blue element marked "M" or "MK".

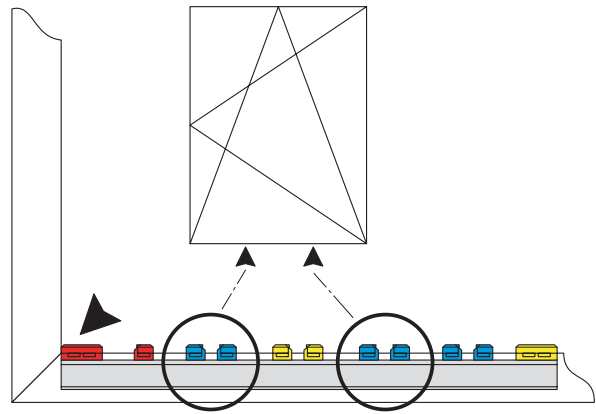

M bottom horizontal

Mounting shear and corner hinges

See figure: Shear and corner hinges

- Fix the shear hinge (2) and corner hinge (1) with screws.



Note: Window builders must ensure that hinges and their anchorings are designed to support the expected loads and professionally mounted.

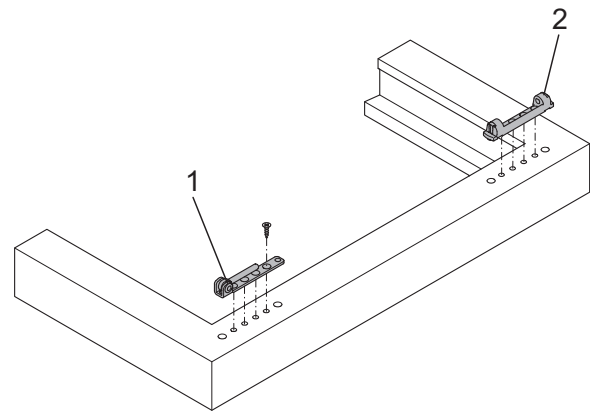

Shear and corner hinges



Important: The screw connections of the load-bearing fitting components, such as corner, shear and sash hinges must be performed according to the TBDK guidelines. Adapt the drilling diameter for the fixing screws, the screw diameter and the screw length to the load situation.

Sash installation and removal

Surface-mounted hinge parts

Fitting the sash

- Mount the sash, adjust for a good seal and fit the pin to secure against the shear hinge.
- Push all end caps and sealing caps onto the shear and corner hinges.

i Note: Insert the pin from the underside (see arrow).

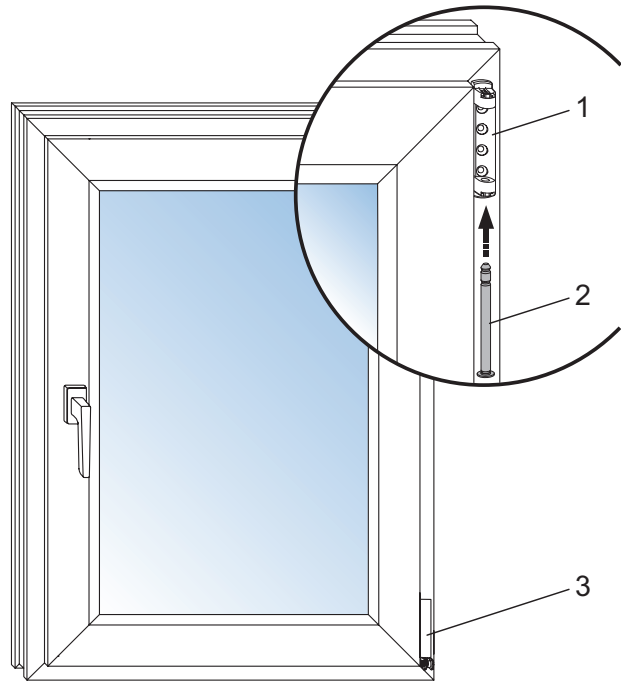

Shear and corner hinge

Removal of the sash

- Close the sash.
- Release the pin from the shear hinge.
- Remove the sash.

! Please note! Damage to shear hinge. In case of improper use and if you attempt to drive out the pin forcibly, the scissor stay will be damaged. Use only a screwdriver or pin-pulling device to release the pin as shown in the figure.

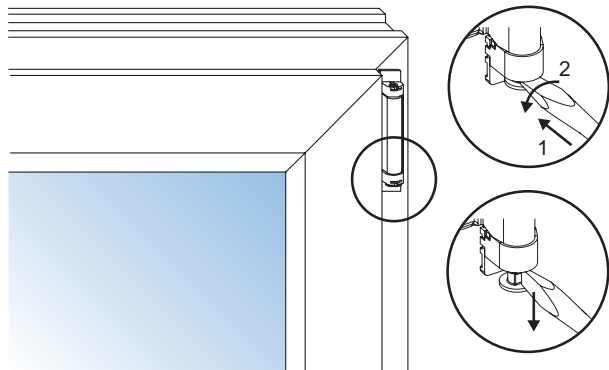

Support the sash!

! In order to save the sash hinge and corner hinge from damage, sagging of the sash during assembly must be prevented (give horizontal support)!

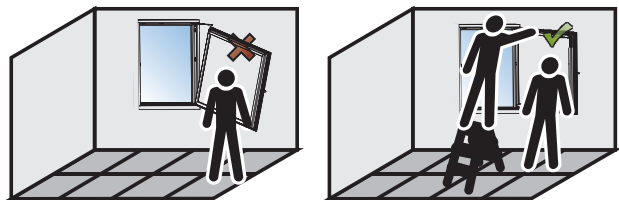

! Important: Secure the window sash against falling. Take the heavy sash weight into account!

! Important: Secure the window sash against falling. Take heavy sash weight into account. Two people should carry the sash if necessary.

Notes on professional fitting and removing of sashes

Notes on professional mounting and dismantling of window sashes are given on our mounting advice. We recommend to place this mounting advice on the window sash.



For withdrawing the shear hinge pin we recommend you to use the pulling device (see product page). If a screwdriver is used, please make sure that the powder coating of the hinge is not damaged.

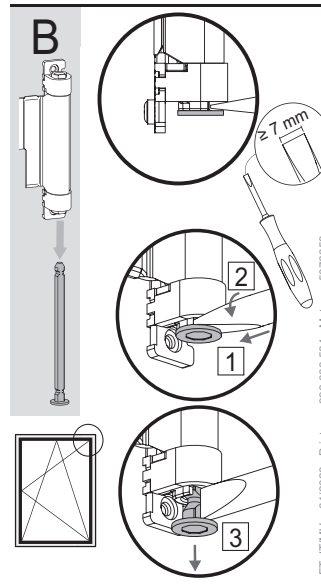
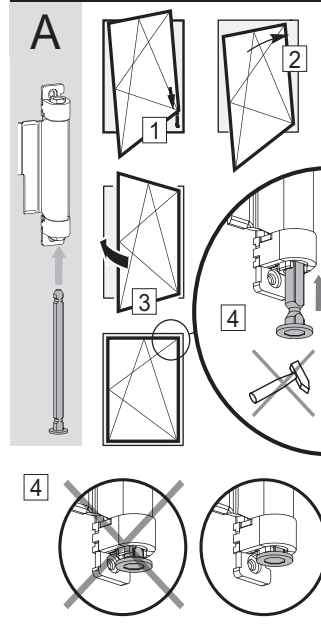

FT JTMV - 01/2020 - Printno. 996 000 584 - Maßno. 5076353

Operation / operating sequence

activPilot Comfort PAD (handle on drive side)

Frame parts: SBS...PAB

Operating sequence: locked position – turn position – parallel action

- If the handle is moved to the crosswise position from below, the fitting is in the turn position. The sash is brought into the parallel position by turning further by 90° to the 180° position. To close the window, the handle must be turned downwards to the initial position.



Burglar resistance according to DIN 18104-2 only in these positions. The handle must be securely locked.

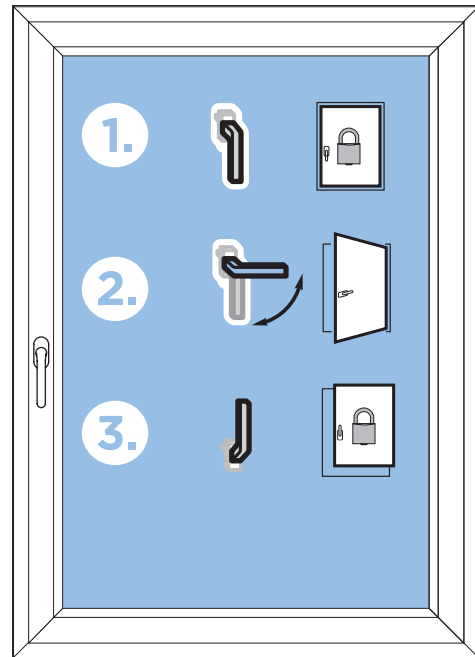

activPilot Comfort PAD (handle on drive side)

activPilot Comfort PAD (bottom handle)

Frame parts: SBS...PAB

Operating sequence: locked position – turn position – parallel action

- If the handle is moved from the diagonal position (locked) to the vertical position, the fitting is in the turn position. The sash is brought into the parallel position by turning further by 90° to the 180° position. To close the window, the handle must be returned to the initial position.



Burglar resistance according to DIN 18104-2 only in these positions. The handle must be securely locked.

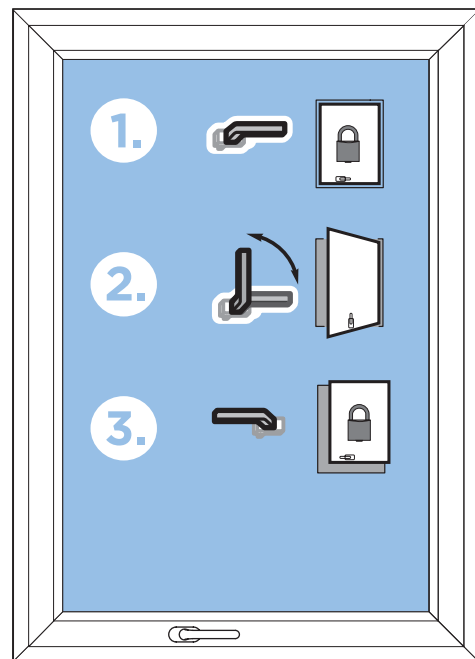

activPilot Comfort PAD (bottom handle)

Operation / operating sequence

activPilot Comfort PAD (handle on drive side)

Frame parts: SBS...PAD

Operating sequence: locked position - parallel action - turn position

- If the handle is moved to the crosswise position from below, the fitting is in the turn position. The sash is brought into the parallel position by turning further by 90° to the 180° position. To close the window, the handle must be turned downwards to the initial position.



Burglar resistance according to DIN 18104-2 only in these positions. The handle must be securely locked.

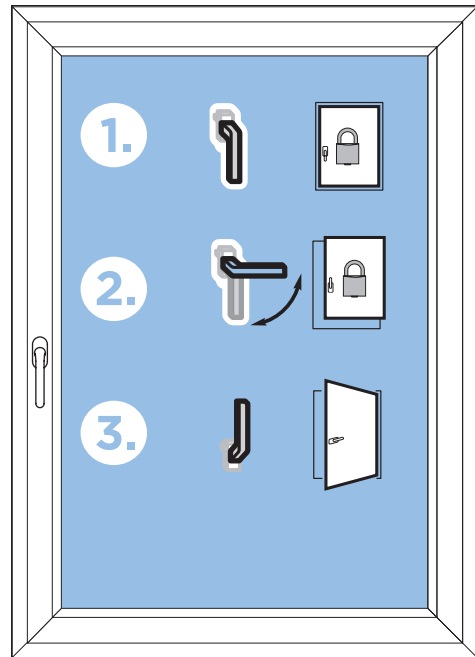

activPilot Comfort PAD (handle on drive side)

activPilot Comfort PAD (bottom handle)

Frame parts: SBS...PAD

Operating sequence: locked position - parallel action - turn position

- If the handle is moved from the diagonal position (locked) to the vertical position, the fitting is in the parallel position. The sash is brought into the turn position by turning further by 90° to the 180° position. To close the window, the handle must be returned to the initial position.



Burglar resistance according to DIN 18104-2 only in these positions. The handle must be securely locked.

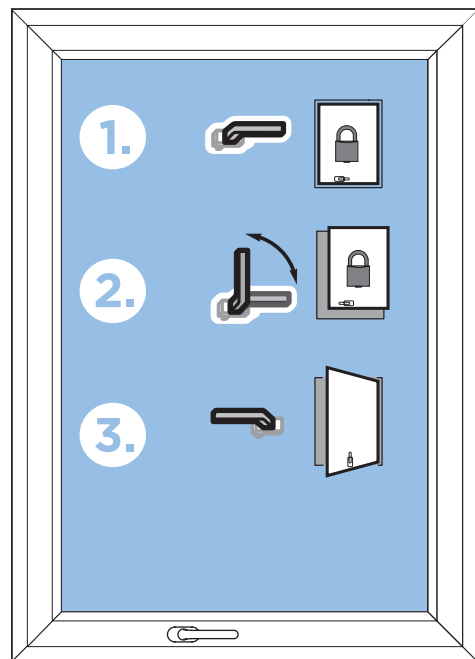

activPilot Comfort PAD (bottom handle)

Technology and function description

Operating sequence: locked position – turn position – parallel action

See figure: Function SBS.K.PAB...PAS

- If the octagonal locking bolt is in position 1, the window is locked.
- If the octagonal locking bolt is in the centre (position 2), the window is in the turn position.
- If the octagonal locking bolt is in position 3, there is an opening gap of approx. 6 mm in the parallel position.

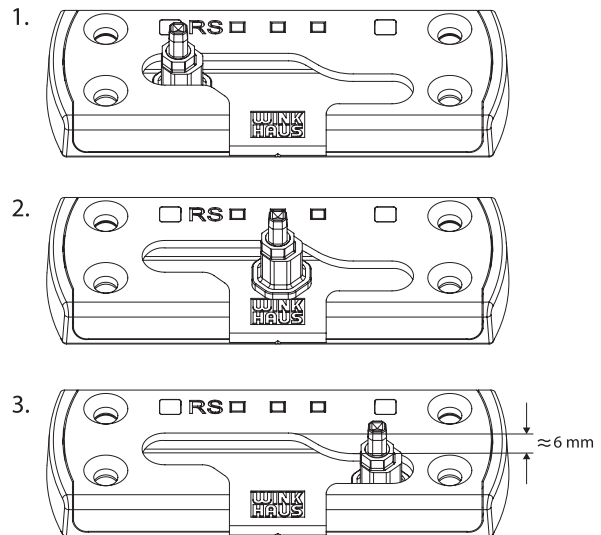

Function SBS.K.PAB...PAS

Technology and function description

Operating sequence: locked position – parallel action – turn position

See figure: Function SBS.K.PAD

- If the octagonal locking bolt is in position 1, the window is locked.
- If the octagonal locking bolt is located in the centre (pos. 2) the window is opened 6 mm in the parallel position.
- If the octagonal bolt is in position 3, the window is wide open (turn position).

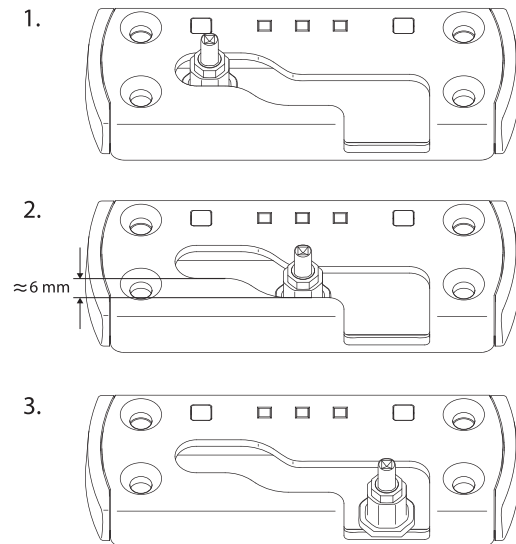

Function SBS.K.PAD

Operating and maintenance manual for the window company

General notes and safety advices

activPilot

These instructions are intended for the window company. They describe essential adjustment and maintenance work for activPilot fittings. Please observe the following notices: Fitting parts are to be tested regularly to ensure they are seated firmly and checked for wear. Fastening screws are to be retightened and parts replaced as necessary. Their functionality is to be retested afterwards. Fittings may only be cleaned with mild, ph-neutral cleaning agents in diluted form. Use only cleaning agents which do not degrade the corrosion protection on fitting parts. Never use aggressive, acidic or caustic cleaners, scouring agents or sharp objects to clean fitting parts. Always also observe the guideline for product specifications/notices and liability when making adjustments or performing maintenance.

This information can be obtained at the following Internet address:

<http://www.beschlagindustrie.de/ggsb/richtlinien.asp>

Combination of corner hinge / sash hinge EL.C... and FLC

Sash hinge without additional function

Sash hinge height adjustment (± 3 mm) and corner hinge side adjustment (± 2 mm) with 4 mm Allen key

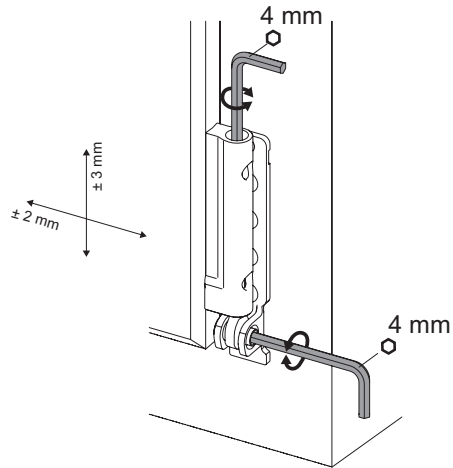

Sash hinge without additional function

Octagonal bolt

Regulate the contact pressure between the sash and the frame (± 0.8 mm) by turning the octagonal bolt. The adjustment can be carried out by means of the Winkhaus adjustment key (V.ST.SCH.HV-11).

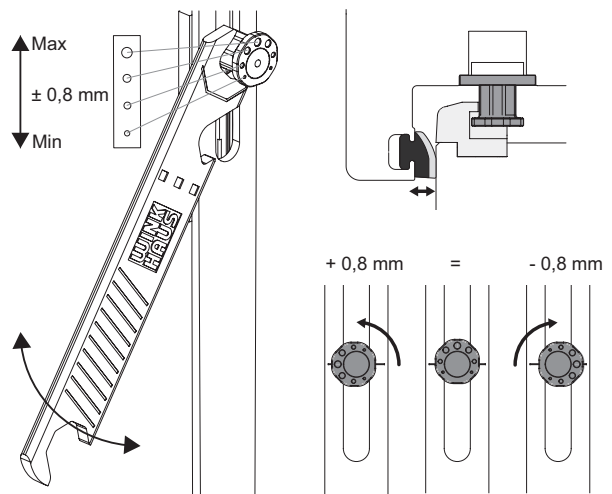

Octagonal bolt

Shear retraction

The progressive shear pull-in is adjustable from 18 to 28 mm. Release the catch by pulling up on the adjustment latch then pivot the adjustment latch away from the overlap.

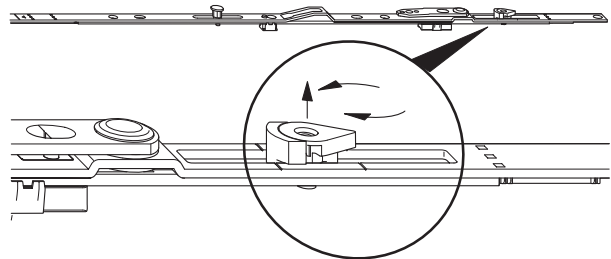

Shear retraction

Determination of sash inclination - Adjustment on the shear

Lifting and lowering the sash (from -2 to +3.5 mm) by means of a 4 mm Allen key.

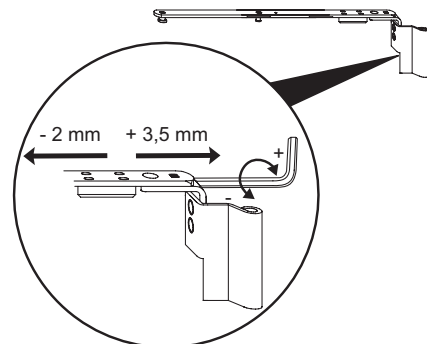

Shear - Rectangular window

Maintenance

Lubrication points

See figure: Overview of lubrication points

The figure shows the location of possible lubrication points which should be lubricated at least once a year (every six months for school and hotel buildings).

Positions A, C, D = lubrication points relevant to function.



Note: the fitting schematic shown adjacent does not necessarily match the existing fitting. The number of locking positions will vary depending on size and type of the window sash.

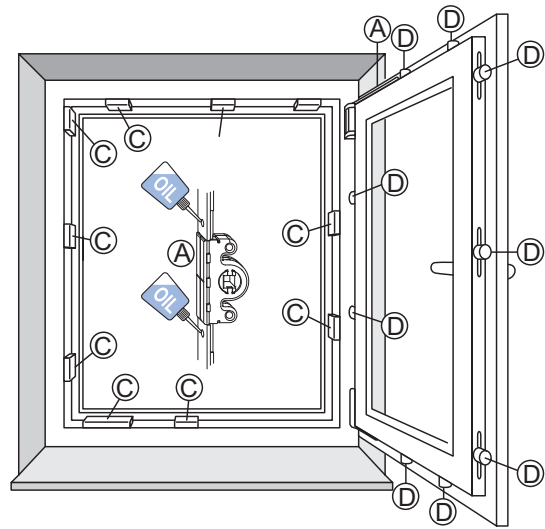

Overview of lubrication points



Please note! Risk of injury. The window could fall on removal and thus injure persons. Do not remove the window for maintenance.

Locking keeps

See figure: Lubrication points

To keep fittings running smoothly, you must lubricate the keeps at least once a year.

- Lubricate the keeps (C) at the run-in side with technical Vaseline or any other suitable grease.
- Coat the running surfaces of the locking bolts (D) with an oil that is free of resins and acids.

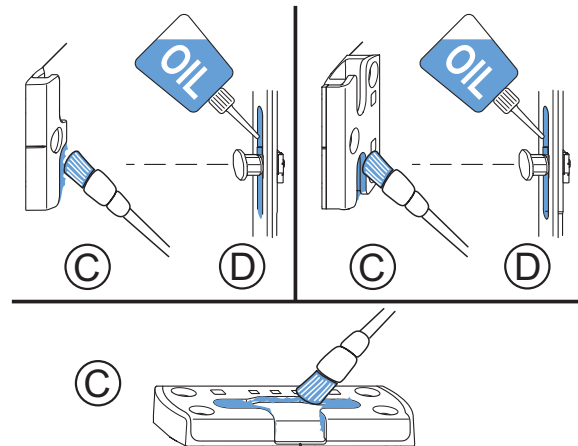

Lubrication points

Ascertaining the run-in sides

See figure: Run-in sides

- Left-handed window; handle right
- Right-handed window; handle left

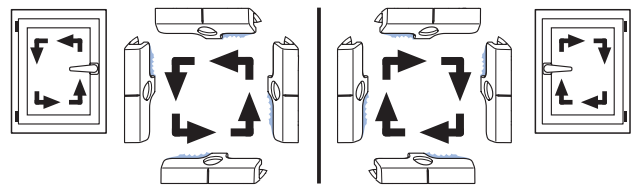

Run-in sides

Shears

See figure: Shears

All of the shear's contact points with the top rod should be oiled at least once annually.



Note: The shear hinge must not be oiled or greased.

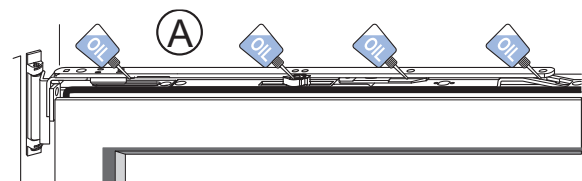

Shears



Note: Please make sure the shear is clean in the upper area.

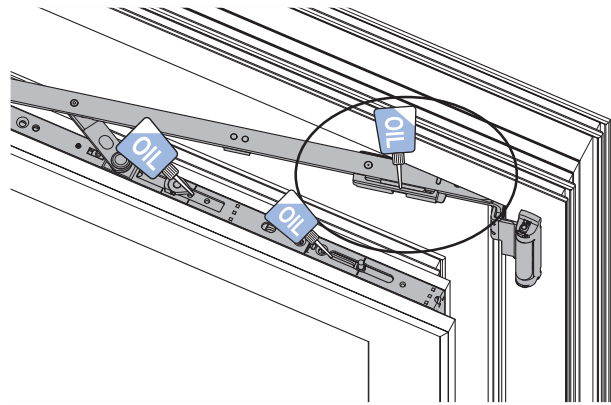

Protection from dirt and dust

Sash hinges

See figure: Sash hinges

All moving contact points on the sash hinge should be greased with a suitable lubricant once annually. Coat lubricating points with non-resinous, non-corroding grease.

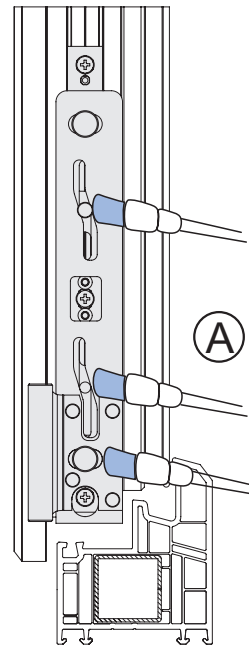

Sash hinges



Note: The running surfaces of the adjustment mechanism of the keep must be kept clean.

Aug. Winkhaus GmbH & Co. KG

August-Winkhaus-Straße 31
48291 Telgte, Germany
T +49 2504 921-0
F +49 2504 921-340

winkhaus.de
fenstertechnik@winkhaus.de